

IP Office Release 6

Product Description



© 2010 AVAYA All Rights Reserved.

Notice

While reasonable efforts were made to ensure that the information in this document was complete and accurate at the time of printing, Avaya Inc. can assume no liability for any errors. Changes and corrections to the information in this document may be incorporated in future releases.

Documentation Disclaimer

Avaya Inc. is not responsible for any modifications, additions, or deletions to the original published version of this documentation unless such modifications, additions, or deletions were performed by Avaya.

Link Disclaimer

Avaya Inc. is not responsible for the contents or reliability of any linked Web sites referenced elsewhere within this Documentation, and Avaya does not necessarily endorse the products, services, or information described or offered within them. We cannot guarantee that these links will work all of the time and we have no control over the availability of the linked pages.

License

USE OR INSTALLATION OF THE PRODUCT INDICATES THE END USER'S ACCEPTANCE OF THE TERMS SET FORTH HEREIN AND THE GENERAL LICENSE TERMS AVAILABLE ON THE AVAYA WEBSITE AT <http://support.avaya.com/LicenseInfo/> ("GENERAL LICENSE TERMS"). IF YOU DO NOT WISH TO BE BOUND BY THESE TERMS, YOU MUST RETURN THE PRODUCT(S) TO THE POINT OF PURCHASE WITHIN TEN (10) DAYS OF DELIVERY FOR A REFUND OR CREDIT.

Avaya grants End User a license within the scope of the license types described below. The applicable number of licenses and units of capacity for which the license is granted will be one (1), unless a different number of licenses or units of capacity is specified in the Documentation or other materials available to End User. "Designated Processor" means a single stand-alone computing device. "Server" means a Designated Processor that hosts a software application to be accessed by multiple users. "Software" means the computer programs in object code, originally licensed by Avaya and ultimately utilized by End User, whether as stand-alone Products or pre-installed on Hardware. "Hardware" means the standard hardware Products, originally sold by Avaya and ultimately utilized by End User.

License Type(s): Designated System(s) License (DS).

End User may install and use each copy of the Software on only one Designated Processor, unless a different number of Designated Processors is indicated in the Documentation or other materials available to End User. Avaya may require the Designated Processor(s) to be identified by type, serial number, feature key, location or other specific designation, or to be provided by End User to Avaya through electronic means established by Avaya specifically for this purpose.

Copyright

Except where expressly stated otherwise, the Product is protected by copyright and other laws respecting proprietary rights. Unauthorized reproduction, transfer, and or use can be a criminal, as well as a civil, offense under the applicable law.

Third-Party Components

Certain software programs or portions thereof included in the Product may contain software distributed under third party agreements ("Third Party Components"), which may contain terms that expand or limit rights to use certain portions of the Product ("Third Party Terms"). Information identifying Third Party Components and the Third Party Terms that apply to them is available on Avaya's web site at: <http://support.avaya.com/ThirdPartyLicense/>

Avaya Fraud Intervention

If you suspect that you are being victimized by toll fraud and you need technical assistance or support, call Technical Service Center Toll Fraud Intervention Hotline at +1-800-643-2353 for the United States and Canada. Suspected security vulnerabilities with Avaya Products should be reported to Avaya by sending mail to: securityalerts@avaya.com.

For additional support telephone numbers, see the Avaya Support web site (<http://www.avaya.com/support>).

Trademarks

Avaya and the Avaya logo are registered trademarks of Avaya Inc. in the United States of America and other jurisdictions.

Unless otherwise provided in this document, marks identified by "®," "™" and "SM" are registered marks, trademarks and service marks, respectively, of Avaya Inc. All other trademarks are the property of their respective owners.

Documentation information

For the most current versions of documentation, go to the Avaya Support web site (<http://www.avaya.com/support>) or the IP Office Knowledge Base (<http://marketingtools.avaya.com/knowledgebase/>).

Avaya Support

Avaya provides a telephone number for you to use to report problems or to ask questions about your contact center. The support telephone number is 1 800 242 2121 in the United States. For additional support telephone numbers, see the Avaya Web site: <http://www.avaya.com/support>.

Contents

1. Introduction

Avaya IP Office.....	7
What's New in IP Office Release 6.....	11
Voice Communication Solution Features.....	14
Data Communication Solution Features.....	15
Applications Platform Features.....	16
Management Tools.....	17
Scalable Platform.....	17
Telephone Options.....	18
Application and Feature Licensing.....	18

2. IP Office Essential Edition PARTNER Version

Hardware	21
Telephones.....	23
System Administration.....	28

3. IP Office Platform

IP Office Control Unit.....	45
IP500 Base Cards.....	47
IP500 Trunk Cards.....	52
External Expansion Modules.....	54

4. Telephones

9600 Series IP Telephones.....	59
1600 Series IP Telephones 1400 Series Digital Telephones.....	68
5402, 5602 SW, 2402, 4602 SW Telephone.....	77
5410, 5610 SW, 2410, 4610 SW Telephones.....	80
5420, 5621, 2420, 4621, 4625 Telephones.....	82
EU24 and EU24 BL Expansion Modules.....	84
T3 Telephones.....	85
System Button Module Support.....	89
Wireless and Remote Phone Solutions.....	90
Analog Telephones.....	115
Headsets	123
Summary	124

5. Features

Basic Call Handling.....	127
Advanced Call Handling.....	131
Key and Lamp Operation.....	138
Outbound Call Handling Features.....	141
Forwarding.....	144
Avaya Digital and IP Phones.....	146
Inbound Call Handling.....	151
Contact Center Features.....	154
Miscellaneous Features.....	155
System Short Codes.....	156

6. IP Telephony

Gateways, Gatekeepers and H.323 - Technology Overview	160
IP Telephony Features.....	161
SIP Endpoint Support.....	162

Power Options for IP Telephones.....	165
VoIP FAQ	167

7. Public and Private Voice Networks

Private Circuit Switched Voice Networking.....	173
Public Voice Networking.....	174
Session Initiation Protocol (SIP).....	178
Packet Based Voice Networking.....	181
Supplementary Services within IP Networks.....	182
Small Community Networking.....	183
Internetworking with Other Avaya Products.....	185
Common Networking Features.....	188

8. Data Networking Services

LAN/WAN Services.....	192
Internet Access.....	192
Remote Access Features.....	193
LAN to LAN Routing.....	193
Data Networking Features.....	194

9. User Call Control Applications

one-X Portal for IP Office.....	202
IP Office Video Softphone.....	211
Feature Summary.....	217

10. Receptionist

SoftConsole Options.....	225
SoftConsole Administration.....	226
SoftConsole PC Requirements.....	226

11. Computer Telephony Integration

CTI with IP Office.....	229
TAPILink Lite (1st Party TAPI Support).....	230
TAPILink Pro (3rd Party TAPI Support).....	230
Support for Developers.....	230

12. Messaging

IP Office Essential Edition - Embedded Voicemail... ..	233
IP Office Preferred Edition - Voicemail Pro.....	234
IP Office Preferred Edition - VoiceMail Pro Resilience and Backup.....	237
Interaction of Voicemail with Email Systems.....	240
Unified Messaging Service (UMS).....	241
Fax Messages.....	243
Text-to-Speech Email Reading (Microsoft Exchange only)	244
Networked Messaging.....	245
Auto Attendant.....	246
Personal Numbering.....	247
Accessing Database Information within Call Flows (IVR)	248
Using Text To Speech (TTS) Facilities within a Call Flow	249
Visual Basic (VB) Scripting.....	250
Extended Personal Greetings.....	251
Hunt Group Broadcast Messages.....	252
Personal Distribution Lists.....	252
Cascaded Out-Calling.....	253
Campaign Manager.....	254

Call Recording.....	255
IP Office ContactStore.....	256
Centralized Messaging with Avaya Communication Manager	258
Voicemail Feature Comparison.....	259
PC Requirements.....	263
13. Mobility	
On-Site Mobility.....	266
External Mobility.....	268
3rd Party Mobility Solutions for Use with IP Office...	271
14. Audio Conferencing	
IP Office Preferred Edition Meet-Me Conferencing Solution	275
IP Office Conferencing Capacity.....	276
IP Office Standard Conferencing Features.....	277
15. The Contact Center	
Customer Call Reporter.....	280
16. Management Utilities	
IP Office Manager.....	291
Monitor	294
Simple Network Management Protocol (SNMP).....	295
System Status Application.....	296
17. Configurations	
Country Availability.....	300
Sample Configurations.....	301
18. TAPI Functions Supported by IP Office	
TAPI 2.1 Functions Supported.....	306
TAPI 3.0 functions supported.....	306
Device-Specific Data.....	307
DevLink Fields.....	308
19. Technical Specifications	
Interfaces	313
Protocols	314
PC Specification.....	316
20. Licenses	
21. Appendix	
IP412 Control Unit.....	332
IP406 V2 Control Unit.....	334
IP400 WAN3 10/100.....	336
IP400 So8 Expansion Module.....	336
Small Office Edition.....	337
IP400 Trunk Interface Cards.....	343
IP500 BRI So8 Module.....	345
IP400 Phone Module.....	346
IP400 Digital Station V2 Module.....	347
IP400 Analog Trunk 16 Module.....	348
Internal Daughter Cards.....	349

Chapter 1. Introduction

1. Introduction

This document is not a contractual document. The specification of the Avaya IP Office family is subject to change without notice. Not all components and features documented are available in all territories, refer to your Avaya Representative for further details. This document should be read in conjunction with any issued technical bulletins and/or product offer announcements.

Avaya IP Office

Simple, Powerful Communications for Small Businesses.

What is IP Office?

IP Office is a versatile communications solution that combines the reliability and ease of a traditional telephony system with the applications and advantages of an IP telephony solution. This converged communications solution can help businesses reduce costs, increase productivity, and improve customer service.

How can I use it in my business?

Avaya IP Office unifies your communications, providing your employees with a solution that lets them handle all their business communications on the device of their choice: their laptop, mobile phone, office phone or home phone— using wired, wireless or broadband connections.

What are my choices?

Successful companies are always looking for new ways to do more with less—keeping their business flexible, innovative and competitive without driving up operating costs and capital expenses. Avaya IP Office is the right choice for any small business today—whether you are 5, 25 or 250 employees... just getting started or already established... have a single office, a home office or multiple stores/sites.

Does your business have one location? Multiple locations? Are you a branch office of a larger organization? A home office? With IP Office you can tailor the solution to your user needs (e.g. Teleworker, Mobile Worker, Customer Service Agent, etc.). Whether you have 2 employees, 200 or more, IP Office is the right choice.

IP Office: Three key things to know

Every small and mid-size business needs ways to reduce costs and improve the way it operates. Like every business, you're looking to keep all your customers, add new ones and grow at the pace that's right for you. Avaya understands this. With over one hundred years of experience as a leader in communications, we know that the right solution for your business is one that helps you increase profitability, improve productivity and gain competitive advantages.

Serving Customers Effectively with Unified Communications

Your office phone, cell phone, e-mail, texting, instant messaging and more are all essential to the way you work today. Unlike other solutions, Avaya IP Office uses built-in intelligence to simplify your use of wired, wireless and Internet communications. Instead of keeping your communications separate, Avaya IP Office brings them together so you can easily turn a home or mobile phone into an office extension, collaborate with dozens of customers or staff members on a conference call and get detailed reports that show how well your company is responding to customers. With rich functionality, IP Office naturally creates new ways of thinking about the role communications can play in your business.

See what Avaya can do for you

You need a communications system - every business does. To find one that's right for your business, start with Avaya. With solutions like IP Office, we're revolutionizing how small and mid businesses communicate. Now is the time to see what an Avaya solution can do for your business.

Reduce monthly costs. Now.

IP Office will help you lower the cost of communications, with capabilities like conferencing, making calls over a managed Internet service (Voice over IP) and the "all-in-one" benefits of a converged communications system.

Leave the office. Be accessible.

With easy, flexible options for call/message forwarding and one-number reachability, IP Office keeps everyone in touch. Get the freedom to go where you want and never miss important business calls.

Serve better. Sell more.

IP Office can give you a customer sales and service center designed for your needs and your budget- with all the routing and reporting capabilities you need. Deliver the personal service that builds sales and loyalty.

Get connected.

Talk to your Avaya BusinessPartner. Discuss where you want communications to add value to your business. Learn about the different service and support options that are available. See why thousands of growing businesses rely on the innovative Avaya IP Office solution.

The right choice for you and your business.

How we communicate is a personal choice - it has to match the needs of your business. And your needs change depending on whether your employees are working in the office, at home, or on the road. That's why when you choose IP Office you can also choose from a whole range of communication tools and applications designed to boost productivity. Choose a basic phone or one with all the bells and whistles. Connect our IP phones directly to your office LAN - also use them at home and get all the features you have at the office. Avaya IP Office Phone Manager software can turn the screen of your PC into a phone. And our wireless solutions make it easier to roam the office. With all of our IP Office capabilities, our goal is to make your communications simple and cost-effective. Let your Avaya BusinessPartner put together a selection of tools and applications that's right for you.

Fine-tuning performance.

How many calls are you handling an hour, a day? What are your peak calling periods? How many calls typically turn into sales? Avaya IP Office reporting capabilities can help you measure and manage your availability and response to customers.

Day-to-day administration.

Once your system is up and running you will benefit from the graphical administration tools that simplify day-to-day tasks, such as updating directories and moving phone extensions.

Getting started.

Is your communications network ready for IP Office? We'll make sure. Avaya has created a whole set of assessment and automated configuration tools to make sure that when your system is installed it's ready to meet your needs starting Day One.

Keeping ongoing management simple.

Concerned about needing extra resources to administer a system as powerful as IP Office? There's no need for worry. IP Office comes with a whole set of graphical tools to keep ongoing management simple.

Does my current phone system give my business what it needs?

If it is based on old technology, probably not. Your competitors will react faster and appear more professional with the latest in communications software. IP Office delivers the capabilities that allow you to keep up with or overtake the competition.

Do I need to understand the technology to implement it?

No. IP Office is designed specifically to give you more functionality without making more demands on your resources. Rely on your certified Avaya BusinessPartner for support before, during and after your purchase. We'll take care of you so you don't have to worry.

Do I need to spend a lot?

Not at all. You have choices based on your budget needs. Easy leasing or financing plans not only make this affordable; they help you quickly cut monthly expenses immediately. And you only have to buy/lease what you need, when you need it.

Is IP technology established and reliable?

Yes. With over 150,000 systems deployed worldwide (Avaya is #1 in Enterprise and IP Telephony shipments - source Dell'Oro and Synergy Research, Q4 2007), Avaya IP Office has the track record businesses like yours can rely on. Aside from receiving the Internet Telephony 'Excellence Award' in 2008 and What to Busy for Business in 2009, customers like you are saving money and boosting productivity. Many are managing the system themselves via graphical tools.

I have old systems but am adding an office. Should I consider newer technology?

Not only would this be a way for you to experience the rich functionality of the latest communications applications, but we may be able to network with your existing equipment, as well as provide a gradual migration plan for your other locations.

How quickly can I get up and running?

Just say "when"- an authorized Avaya BusinessPartner can tailor a solution to your needs and your budget. By saving you money and helping you grow, IP Office repays your investment and lets you reallocate resources to other business priorities.

Lowering long distance costs.

Routing phone calls over IP lines- Voice over IP- is growing in popularity. Particularly in the case of international calls, VoIP generates significant savings. If your company is already linking multiple offices using high-speed data circuits, the VoIP capabilities in IP Office make it possible to route voice calls over the existing infrastructure, providing another way to lower costs and leverage your investment. However you do it, the VoIP capabilities of IP Office are a way to put money back in your pocket.

Eliminating conferencing fees.

For connecting with partners, suppliers and dispersed employees, conference calls keep people working together and keep travel costs down. Many companies rely on third party teleconferencing services and pay a price for the convenience. This is particularly true- and irritating- if a call that's scheduled doesn't happen: you still pay the fee.

Now there's an alternative that will save you money. With Avaya IP Office, your organization can have its own private, secure conference bridge and entirely eliminate fees to third party providers.

Supporting multiple offices/remote workers

When employees can't get to the office (because of storms, medical issues or other reasons) but can still work productively at home, your business benefits. IP Office Phone Manager lets you turn any PC into a phone, making it easy and productive to work anywhere. And the ability to network phone systems and share messaging systems between offices reduces up front investment and drives long-term productivity.

And keep in mind...

IP Office delivers a whole range of capabilities. Only you can put a number on the value that many of these capabilities will have for your business.

Examples:

- Having calls automatically routed to a cell phone or other location, so important customers can get through to the right person in real-time
- Being able to operate as a 24/7 business, without a 24/7 staff
- Using your communications to quickly identify when your top customers call.

How IP Office is benefiting businesses today.

- More room for sales
With IP Office, a leading provider of commercial food service equipment now handles 50% more calls per day, without extra staff and without sacrificing the personal service it knows is the key to sales.
- At the head of the class
By relying on IP Office to connect nearly 50 buildings, a public school system saved thousands of dollars on inter-office calls and simplified communications.
- Lowering global costs
By using IP Office to hold teleconferences and make phone calls across the IP network, a strategic consulting firm is saving up to \$30,000 per year.

IP Office can grow as your business grows to meet your needs. Capacities: 2-384 extensions; up to 192 analog lines; 192/240 T1/E1 lines; 128 VoIP trunk lines.

Call handling and messaging.

Get 24-hour support for callers/customers without a 24-hour staff. IP Office has a range of messaging, auto attendant and Interactive Voice Response (IVR) capabilities. Integrate messaging and advanced call handling into your customer service operations. Handle voice mail and email in a single mailbox.

Communication with customers.

Set up a formal or informal customer service center. Integrate your customer data base into your call handling. Manage the quality of your customer interactions.

Work anywhere.

Give your employees all the communications capabilities they have at the office whether they are working from home, a hotel or a remote office.

A complete conferencing solution.

Don't pay any more fees to outside conferencing service providers. Get Web and audio-based conferencing that are easy to set up and use.

Secure converged communications.

Use IP Office as a secure router with a built-in firewall/VPN. Route voice calls over a managed Internet service (VoIP) and pocket the savings. Simple administration Windows-based, graphical tools cut the time and expense of administration.

What's New in IP Office Release 6

IP Office Release 6 is a major release which allows IP Office systems to address better the needs of smaller sites, as well as adding considerable capabilities in the areas of multi-site networking, user productivity and new telephones.

New Platform and Hardware Support

IP Office Control Unit Support

IP Office Release 6 is supported on the IP Office 500 (IP500) and the new IP500 V2 and as well as the IP406 V2 and IP412 (no longer sold).

IP Office Release 6 is not supported on the Small Office Edition (SOE), IP401, IP403 and IP406 V1.

Note: Not all of the features in IP Office Release 5 are supported on all platforms and all phones- please see each feature's description in the chapter [Features](#)^[126] for details.

IP Office 500 V2 Control Unit

The IP500 V2 is a new control unit which is an evolution of the existing IP500 and is fully backwards compatible with it. It has 4 card slots into which all existing IP500 cards can be inserted, as well as several new cards which are introduced with Release 6. The IP500 V2 requires the presence of a system SD (Secure Digital) card to operate and to act as its feature key. For more information see the chapter [IP Office Platform](#)^[44]. The IP500 V2 operates in standard IP Office mode as well as a new Avaya IP Office Essential Edition PARTNER Version.

SD Card Features

As well as acting as the Feature Key for the IP500 V2 system, the system SD card acts as storage for Essential Edition messaging, with two ports of voicemail enabled as standard. Additional increments of 2 ports can be added through licenses up to a total of 6 ports. The system SD card also enables faster implementation times since it can be pre-loaded with the correct software, configuration and licenses before installation and then sent to site where it can simply be inserted in the system to complete installation with no management software required.

[material codes, software included]

Combination Card

The IP500 V2 supports up to two new Combination Cards which combine multiple station and trunk ports with voice over IP resources in a single cost effective card. These cards are available in two variants supporting either analog or ISDN BRI trunks.

For more information see the chapter [Features](#)^[126].

ETR 6 Card

The IP500 V2 supports up to three new ETR 6 Cards which support up to 6 PARTNER ETR phones. The cards are supported in Essential Edition – PARTNER Version mode in North American locales. For more information see the [IP Office Essential Edition - PARTNER Version](#)^[20] chapter.

Essential Edition – PARTNER Version

The IP500 V2 supports a new mode of operation which resembles PARTNER ACS in many respects, including enhanced key and lamp operation, simplified administration and support for ETR telephones. This mode is only available in North America and Mexico locales. For more information see the [IP Office Essential Edition - PARTNER Version](#)^[20] chapter.

New Telephone Support

Release 6 adds support for the following new telephone families:

- 1400 Series Digital Phones: 1403, 1408, 1416 (plus the DBM32 button module planned to follow during the first half of 2010)
- 1600 International Series IP Phones: 1603-I, 1603SW-I, 1608-I, 1616-I plus BM32 button module
- 9600 Series IP Phones: 9620L, 9620C, 9630, 9630G, 9640, 9640G, 9650, 9650C plus SBM24 button module
- ETR PARTNER Phones: 6D, 18D, 34D (Essential Edition – PARTNER Version only in North America)

Licenses for Avaya IP Telephones

Release 6 removes the need to purchase VCM channel licenses and instead requires the use of IP Telephone licenses for Avaya IP phones. This makes the configuration and purchase of IP telephony simpler and more intuitive. See the Chapters ["IP Telephony"](#)^[158] and ["Licenses"](#)^[326].

New Telephone Features

Release 6 adds support for en-bloc (on-hook) dialing as well as distinctive ringing for selected telephones.

New Softphone

Release 6 adds the new Avaya IP Office Video Softphone for Teleworkers and Power Users. See the Chapter ["User Call Control Applications"](#) ^[202].

New Licenses for Editions and User Profile

Release 6 builds on the new application licensing framework introduced in Release 5 by allowing all the functionality of a system edition or user profile to be enabled with a single license key rather than multiple licenses. See the Chapter ["Licenses"](#) ^[320].

In addition a new user profile of Office Worker has been introduced giving access to the call and message control functionality of one-X Portal for IP Office from within the office.

The Teleworker profile license now additionally enables access to Unified Messaging and the new IP Office Video Softphone.

Access to Phone Manager has now been removed from the user profiles (although legacy Phone Manager licenses remain supported and available).

The four main user profile licenses (Office Worker, Tele-worker, Mobile Worker, Power User) are now distributed around the SCN so that when a user hot-desks from one system to another on the network their profile (Office Worker, Power User, etc) moves with them.

Upgrade License

If upgrading to Release 6 from a previous release an Upgrade License must be present. This comes in three variants:

- standard upgrade to 6.0.
- upgrade to 6.0 for small sites up to 32 users.
- multiple upgrades for several future releases (up to and including Release 10).

For new installations, no upgrade license is required on the IP500 V2 platform.

Small Community Networking Enhancements

Resilient Voicemail & expansion to 1000 users

Enhancements to SIP Trunking

Dial from call log using configurable line prefixes.

Easier setup of incoming SIP calls to Hunt Groups.

Support for SIP session timers.

Multiple account credentials per SIP trunk.

Register SIP Line using domain name.

The Diversion header can be used to present the originating calling id to twinned devices (where supported by the carrier).

Enhancements to ISDN Trunking

The Redirecting Number information element can be used to present the originating calling id to twinned devices (where supported by the carrier).

Calling Name can be presented for outgoing calls (where supported by the carrier).

Enhancements to Mobility

Mobility Callback can save mobile call charges in some countries by allowing a Mobile Worker user to dial into the IP Office using a dedicated number and be called back and presented with dial tone without the original call being answered.

Voicemail Enhancements

Preferred Edition (VoiceMail Pro) now supports Resilient and Distributed voicemail scenarios (see the [Voicemail](#) chapter).

Essential Edition (embedded voicemail) now enables extension numbers to be dialled directly from an Auto Attendant without the need to dial a digit first.

On the new IP500 V2 platform, Essential Edition with 2 ports of voicemail is provided as standard, while additional ports can be added through licenses up to a maximum of 6.

Other Enhancements

Persistent SMDR storage – the buffer for storing SMDR records now persists after a reboot of the IP Office.

Voice Communication Solution Features

IP Office offers a comprehensive list of features and benefits for the small or mid-size business, including:

- **Full PBX features**
Caller ID, Call Forwarding, Conference Calling, Voice Messaging and more.
- **Trunk Interfaces**
A variety of network trunk interfaces, including E1, T1, PRI, ISDN, SIP, analog loop start and analog ground start for comprehensive network connectivity. Not all trunk types are available in all territories, please check for local availability.
- **Extensions**
Support for a range of extensions, from 2 to 384 that provide sophisticated voice performance for new and growing businesses.
- **Telephones**
A variety of telephones including analog, digital and IP hard and soft phones (wired and wireless) that provide the appropriate desktop or device phone for every need.
- **Advanced Call Routing**
Incoming calls are directed to the best available person or messaging service, according to the company's unique criteria.
- **Alternate Call Routing**
Ensures reliable handling of calls by selecting from analog, digital or VoIP trunks.
- **QSIG Networking**
Standards-based multi-site networking to interoperate with other PABXs (licensed feature).
- **Integrated H.323 and SIP Gatekeeper and Gateway for converged communications**
The IP Office acts as an IP telephony server with Quality of Service (QoS) support through DiffServ for routing and up to 128ms of Echo cancellation depending on Voice Compression Module (VCM) card fitted.
- **SIP Trunking**
IP Office 4.0 and above supports SIP trunking to Internet Telephony Service Providers. This approach allows users with non-SIP phones to make and receive SIP calls (licensed feature).

Data Communication Solution Features

For offices with basic data networking needs, IP Office can provide a complete data communications and networking solution:

- **Internet Access**
Firewall protected leased line or dial-up connectivity via PRI, T1 or WAN port: high-speed dialed access, direct leased line connections for high usage and Web site hosting, integral security, and efficient access to information and a larger business presence via the Web.
- **Routing**
Integral Static or Dynamic (RIP I/II) routing for both Internet and Branch-to-Branch solutions.
- **Security**
NAT (Network Address Translation) and built in firewall to protect your internal network and IPSec support allows secure VPN data transmission across public IP Networks using 3DES encryption.
- **DHCP**
Automatic IP address allocation for local and remotely attached PC's and other devices, including IP phones.
- **Remote Access Server**
Access to local LAN servers via optional two-channel V90 modem or digital trunks: individual firewall security, access control per user, and standards-based security enable remote workers.
- **LAN Switching**
The IP500 offers 2 switched Layer 3 Ethernet ports.
- **LDAP client support**
For standards based directory synchronization with one-X Portal for IP Office and Phone Manager.

Applications Platform Features

IP Office provides big business benefits and enhanced productivity for small and mid-size businesses with a full complement of sophisticated applications.

IP Office provides a number of free applications (eg. Phone Manager Lite, Microsoft TAPI service). These applications can be upgraded to provide enhanced functionality through the purchase of license keys.

- **Operator SoftConsole**
A graphical User Interface (GUI) for attendants on their PC desktop for call handling. Works with a telephone and is an easy way to learn and use sophisticated tools in a comfortable environment.
- **one-X Portal for IP Office**
A powerful client/server web application that allows the user to control and manage phone calls from a web browser with the standard LDAP protocol for connectivity to external directories.
- **Open CTI interfaces**
IP Office has a built in TAPI server that integrates easily with popular contact management applications such as Outlook. Sophisticated custom applications can be rapidly developed and deployed with our full software development kit.
- **Voicemail**
Callers can always be answered with a personal voicemail greeting before a message is taken and message notification set. Messages can be shared (forwarded) with colleagues and retrieved by any phone capable of tone dialing. When used with one-X Portal for IP Office, the PC can be used to control message playback.
- **Integrated Voicemail to Email Presentation**
Voice messages can be copied into email messages and delivered into the email system. IP Office uses SMTP or MAPI to deliver a copy of the voice message.
- **Unified Messaging**
The Unified Messaging Service within Preferred Edition provides a higher level of integration to synchronize both voicemail and email inboxes.
- **VoiceMail Pro Web Access**
Together with UMS comes the ability to access voice mails via a web browser. using this voicemail messages can be managed and listen to using either the PC or the IP Office extension.
- **Auto-Attendant**
Simplify service for administrators with this easy-to-use feature with the ability to construct customized automated services allowing callers to efficiently navigate the system, and reach the right person, without the assistance of an operator. Available with Preferred Edition and with Essential Edition.
- **Interactive Voice Response (IVR) and Text to Speech**
Create automated customized systems allowing callers to interact with business information, for example, reading email, account enquiry systems, automated ordering systems, ticket purchasing systems, PIN number checking, remote time sheet management, etc. Enhance these systems by using Text To Speech to read information back to callers. Available with Advanced Edition.
- **Queue Manager and Campaign Manager**
Powerful voice and IVR applications for the Contact Center that facilitate agent and traffic management for better productivity and customer service.
- **Customer Call Reporter**
Available with Advanced Edition and combined with the built-in ACD functionality of IP Office, CCR enables a small business to track and measure customer service and agent productivity levels
 - IP Office + CCR = Informal Call Center
 - The new CCR application delivers:
 - Simple/Intuitive Reporting
 - Browser/Thin Client Architecture
 - Single Server Efficiency (with VoiceMail Pro)
 - Target Segment: Small Business, <30 agents
 - Can support up to 150 agents
 - 30 supervisors
 - one administrator

Management Tools

The IP Office solution (phone system, router/firewall/DHCP server) is easily managed through the IP Office Manager. IP Office Manager is a Windows PC software application that connects to the IP Office system using TCP/IP. It can be on the same LAN as the IP Office, remote on the WAN, or connected via the Remote Access Server with a Telephone Adaptor, Router or the optional internal modem.

The System Status application is a useful diagnostic tool that provides enhanced details about equipment and resources in the IP Office system. This includes indication of alarms and details of current calls in progress for local or remote diagnostics.

Scalable Platform

The IP500 V2 - servers, media modules, trunk interface cards and software applications - give small and mid-size businesses the options they want to meet today's communications needs and plans for the future.

It offers a modular, flexible chassis which with capacity for up to 16 analog trunks or 16 ISDN BRI trunks (32 channels) or 8 digital PRI trunks (up to 192 T1 channels or 240 E1 channels) using internal daughter cards. Up to 12 Expansion Modules may be added to provide a combination of up to 384 analog, digital or IP extensions, with additional analog trunks through external Analog 16 modules. Features include up to 148 optional voice compression channels, 2 independently switched LAN ports and built-in Embedded Messaging with Essential Edition.

Telephone Options

IP Office supports multiple telephone solutions, giving the small and mid-size business maximum flexibility to choose according to their current and future needs (see [Telephones](#) ^[58] for more details):

- **IP Telephones**
IP Office's integral H.323 Server supports Avaya 1600 and 5600 Series IP telephones, selected Avaya 9600 Series IP telephones, Avaya T3 series IP telephones, Avaya 3600 Series Wireless VoIP telephones and IP Office Video Softphone.
- **Digital Telephones**
IP500 Digital Station 8 cards and Combination Cards plus IP Office Digital Station 16 or 30 Expansion Modules support the Avaya 1400 and 5400 Series of digital phones and Avaya T3 Series telephones, plus selected 2400 and 6400 Series phones.
- **ETR Telephones**
IP500 V2 ETR 6 cards support the Avaya ETR phones as used on PARTNER ACS systems (Essential Edition – PARTNER Version only).
- **Analog Phones**
IP500 Phone 2, Phone 8 and Combination cards plus IP Office Phone 16 or 30 Expansion Modules support standard analog phones, faxes and modems, with support for calling line identification and message waiting indication where these services are provided.
- **Wireless Telephones**
Avaya IP DECT base stations can be added to support the Avaya IP DECT 3701 and 3711 telephones as well as the DECT R4 3720 and 3725 telephones. The IP Office Digital Station interfaces support the Avaya 3810 telephone. The Avaya 3600 Series wireless VoIP telephones are also supported.
- **Third Party SIP endpoints**
IP Office's integrated SIP Server supports third-party SIP endpoints such as, desktop telephones, softphones and conferencing speakerphones.

Application and Feature Licensing

Some IP Office applications and features cannot be used unless a valid license key is present in the IP Office system configuration. Each license key is derived from the feature being enabled combined with the serial number of the Feature Key installed with the IP Office system.

IP500 and IP500 V2 systems use a mandatory Feature Key installed with every system.

Licenses are supplied in two forms: time limited trial licenses and indefinite licenses. Trial licenses allow applications to run in fully functional form for 60 days (from the date of license generation), after which time they cannot be used until upgraded at cost to the full license but can be ordered at any time during the product ownership.

For further details of the IP Office licenses including Trial Licenses refer to the [Licenses](#) ^[320] section.

Chapter 2.

IP Office Essential Edition

PARTNER Version

2. IP Office Essential Edition PARTNER Version

The IP Office Essential Edition - PARTNER Version (known hereafter as PARTNER Version) is the next evolution of communications system for small businesses

PARTNER Version is designed to work directly out of the box without any programming or administration, allowing users to immediately make and place calls via analog trunks.

PARTNER Version provides the end user a similar desktop experience as the PARTNER ACS: eg. 2 dedicated intercom buttons, key system functionality, Caller ID, etc. This helps minimize training requirements and provides the end user with the same comfort level they have come to expect with the PARTNER ACS system.

PARTNER Version provides the bulk of the feature set that the current PARTNER ACS R8 supports; plus integrates enhanced features from the IP Office Essential Edition platform, such as Mobile Twinning, Visual Voice Mail, 64-party Conferencing, SIP Trunking, Full PRI/T1 and more.

PARTNER Version provides the same 2-digit extension numbering plan as PARTNER ACS.

PARTNER Version supports all current and "Euro" versions of PARTNER ACS telephones. PARTNER Version also introduces a new line of digital telephones – 14xx Series sets, which will work in conjunction with the PARTNER ETR sets. Also supported is our current 3920 and 3910 wireless products, as well as most analog devices (fax, wireless headsets, analog phones). The original MLS series telephones and older wireless telephones are not supported.

PARTNER Version includes Embedded Voice Mail; providing a 2-port Automated Attendant (upgradeable to 6-ports) and voice mail coverage activated for all telephones.

System Capacities

PARTNER Version supports the following (may not be attained simultaneously):

- 48 Stations:
 - Up to 18 ETR Stations
 - Up to 46 Digital Stations
 - Up to 48 Analog Stations
- 56 Trunks:
 - Up to 12 analog CO lines
 - 1 PRI/T1 (24 lines)
 - Up to 20 SIP lines

System Programming

System programming is accomplished in 2 ways:

- [Telephone User Interface](#) (TUI) from extension 10 or extension 11; and uses the same administration codes as the PARTNER ACS system.
- [Graphical User Interface](#) (GUI) – PARTNER Version provides a "Simplified Manager" mode in the IP Office Manager software; allowing you to program the system in less than 30 minutes

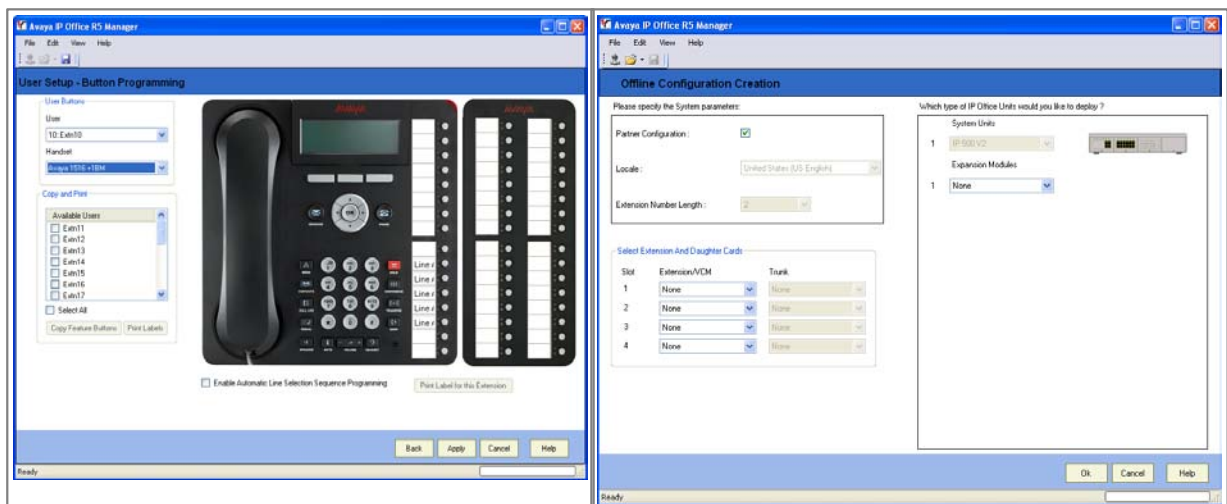

Hardware

Control Unit

PARTNER Version software runs on the IP 500v2 control unit. A PARTNER Version Secure Digital SD card is required and is installed in the rear of the control unit, providing operating software, Feature Key, Licenses and directs the system to boot up in PARTNER mode. An optional SD card may be installed in the Optional SD card slot, providing additional storage for Voicemail recordings, System Logs and redundant backup capability.



Rear View

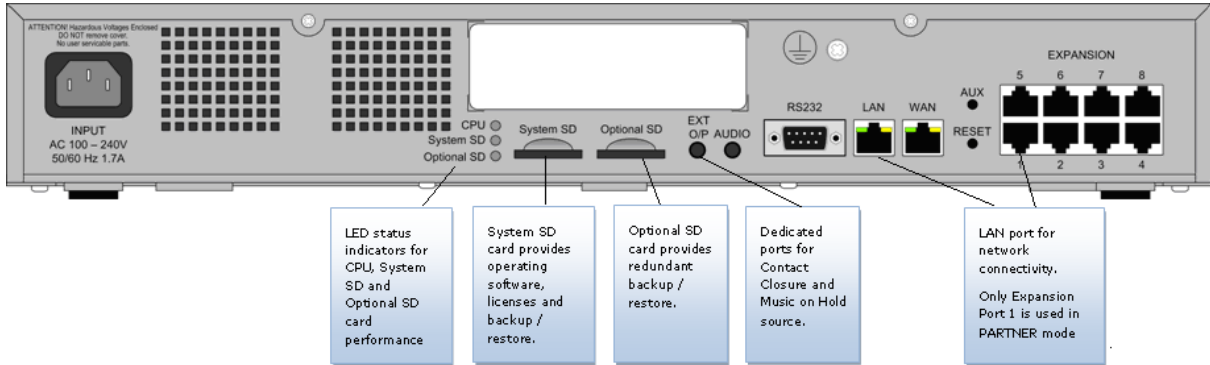

Front View



The front of the IP500v2 Control Unit has 4 expansion bays, which supports the following system modules:

- **Combo Card (Max 2 per system)**
The Combo Card provides 6 Digital Station (DS) ports (Ports 1-6); 2 Analog Station ports (Ports 7-8); 4 CO Line ports (Ports 9-12) and 10 Voice Compression Channels. There are no Power Failure Transfer ports on this card.
- **ETR-6 Card (Max 3 per system)**
The ETR-6 Card provides 6 ETR (PARTNER ACS telephone) Station ports (Ports 1-6); and supports (1) of the following optional Daughter Cards: ATM-4 or PRI/T1. When an ATM-4 is added, ports 7-8 become Power Failure Transfer ports, and ports 9-12 provide 4 additional CO Line Ports.
- **DS-8 Card (Max 3 per system)**
The DS-8 Card provides 8 Digital Station ports (Ports 1-8); and supports (1) of the following optional Daughter Cards: ATM-4 or PRI/T1. When an ATM-4 is added, ports 9-12 provide 4 additional CO Line Ports.
- **Phone 2 (Max 3 per system)**
The Phone 2 module provides 2 additional Analog Station ports and supports (1) of the following optional Daughter Cards: ATM-4 or PRI/T1.
- **Phone 8 (Max 3 per system)**
The Phone 8 module provides 8 additional Analog Station ports and supports (1) of the following optional Daughter Cards: ATM-4 or PRI/T1.



Expansion Carrier

PARTNER Version supports (1) of the following Expansion Carriers:

- DS-16 – provides additional 16 Digital Stations
- Phone 16 – provides additional 16 Analog Stations

Daughter Cards

PARTNER Version supports the following daughter cards, which are mounted on any ETR-6, DS-8, Phone-2 or Phone-8 module:

- ATM-4 – provides 4 analog CO line ports. Supports Caller ID
- PRI/T1 – supports full PRI or T1. Limit 1 PRI/T1 module per system



Telephones

PARTNER Version supports the following telephones:

- [14xx Series Digital Telephones](#) ^[23]
- [Partner ACS Sets](#) ^[24]
- [PARTNER ACS "Euro" Sets](#) ^[25]
- [Wireless Sets](#) ^[26]
- [Analog "POTS" Telephones](#) ^[27]

1400 Series Telephones

The following 1400 series telephones are supported.

- 1416 Display Set
- 1408 Display Set
- 1403 Display Set
- BM32 Button Module



Programmable Buttons

As well as the usual dialing keys, Avaya 14xx digital phones have dedicated function buttons like Mute, Volume, Hold, Conference and Transfer. In addition to these, there are keys that can be programmed with a range of selected special functions. These keys can be used for calling other extensions on the system (Direct Station Select or DSS keys), or can be used for options from speed dialing numbers to controlling features such as Do Not Disturb. Many features use an indicator to show whether a feature is enabled.

Button programming is done through the TUI or Simplified Manager as part of the system configuration.

PARTNER ACS Sets

The following PARTNER ACS telephones are supported on PARTNER Version:

- 6 Button Display Set
- 18 Button Display Set
- 34 Button Display Set (up to 4 per system, 2 per ETR card)



Not Supported:

- Call Assist-48 (CA-48) Adjunct

Default Button Features:

When connected to the PARTNER Version, the top row of buttons on the 18D and 34D sets come pre-programmed with the following features:

- Last Number
- Conference Drop
- Voice Mail Access
- Recall

PARTNER ACS "Euro" Sets

The following PARTNER ACS "Euro" telephones are supported on PARTNER Version:

- 6 Button non-Display Set
- 18 Button non-Display Set
- 18 Button Display Set
- 34 Button Display Set (up to 4 per system)



Not supported:

- Call Assist-24 (CA-24) Adjunct

Default Button Features:

When connected to the PARTNER Version, the top row of buttons on the 18D and 34D sets come pre-programmed with the following features:

- Last Number
- Conference Drop
- Voice Mail Access
- Recall

Wireless Sets

3920 Wireless



3910 Wireless



Analog "POTS" Telephones

PARTNER Version supports a wide variety of industry standard analog telephones and devices, for example: fax machines, credit card readers; wireless headsets, cordless telephones.

Analog devices are connected to the system:

- To one of the analog ports on the Combo Module
- Via a Phone-2 or Phone-8 Module
- To an ETR station port (directly or bridged with a PARTNER ETR telephone set)

The major features work the same, regardless how they are connected: eg. Hold, Conference, Transfer, Call Waiting, Message Waiting, Incoming Caller ID.

Analog phones have access to all dial-code features familiar to PARTNER users: eg. Call pickup, Line pickup, Call Forwarding activation/deactivation, etc.

Analog phones connected to a PHONE or COMBO module default to intercom dial tone. To place an outgoing call, the user will dial 9. Analog phones connected to an ETR module follows programmed Automatic Line Selection.

System Administration

The PARTNER Version can be programmed in 2 ways:

- Telephone User Interface (TUI) from extension 10 or extension 11; and uses the same administration codes as the PARTNER ACS system (see Table 1). Button Programming Features use the same codes as the PARTNER ACS system (see Table 2).

TUI programming is an alternate way to do System Administration and Programming on the PARTNER Version. It is based on the PARTNER ACS TUI, but with improvements.

Using TUI System Administration on ETR and 14xx sets, the buttons under the display become soft-keys which are used to navigate and change the administration items. There are also shortcut codes which enable the administrator to jump to particular administration items.

Centralized Programming is similar to System Administration, but it is used to administer buttons and other options for any phone in the system.

Individual Programming continues to be supported, allowing the station user to program buttons on their sets.

- Graphical User Interface (GUI) – PARTNER Version provides a “Simplified Manager” mode in the IP Office Manager software; allowing you to program the system in less than 30 minutes.

“Simplified Manager” is a PC GUI application inherent to the IP Office Manager application. Although system administration can be completed via either the TUI or GUI method; some advanced features such as SIP and PRI/T1 administration require the Manager application.

When you execute Manager, the program searches for any IP500v2 units running PARTNER Version on your network and will automatically connect using the default login and password. You are then presented with a “Simplified Manager” Screen:

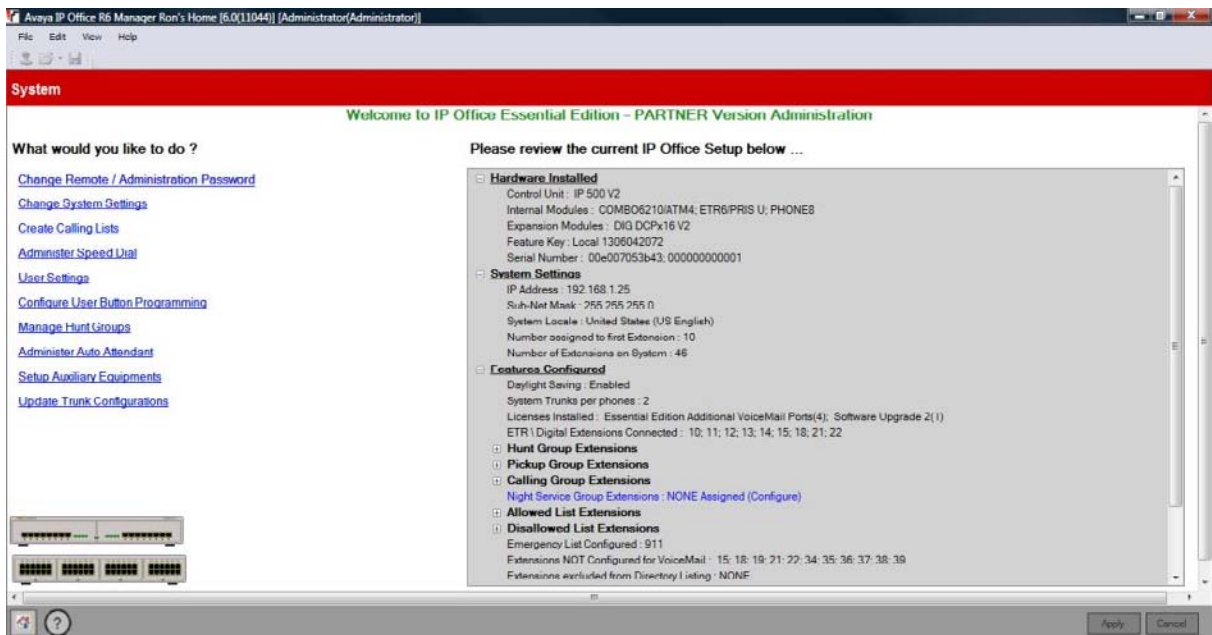

By using the 10 System Hyperlinks, you are able to quickly and easily administer the PARTNER Version system in a short time. Further details can be found in the IP Office PARTNER Version Manager documentation guide posted on the Avaya Support website.

System Features

PARTNER Version provides the majority of the feature set that the PARTNER ACS R8 supports. A listing of the built-in features is detailed on the following page.

Feature Overview		
911 Emergency Dialling [30]	Conference Drop [33]	Music On Hold [37]
Abbreviated Ringing [30]	Contact Closure Support (2 devices) [33]	Mobile Twinning
Absent Text [30]	Copy Settings [33]	Network Time Synchronization [37]
Account Codes [30]	Direct Inward Dialing (DID) [34]	Night Service [153]
Allowed/Disallowed Lists [30]	Direct Line Pickup Features [34]	On Hook Dialing
Application Programming Interface (TAPI) [42]	Display	Paging Features [37]
Attendant/Operator Positions [31]	Display Language [35]	Personal Line Termination [38]
Automatic Callback [31]	Distinctive / Differentiated Ring [35]	Personalized Station Ringing [38]
Automatic Daylight Savings Time [31]	Do Not Disturb (Send All Calls) [35]	POT Support [38]
Automatic Extension Privacy [31]	Doorphones (max of 2) [35]	Privacy [38]
Auto Dialing [31]	Emergency Phone Number List [35]	Recall [38]
Automatic Line Selection [31]	External Hotline [35]	Redialing Features [38]
Automatic VMS Coverage [31]	Extension Hunt Groups [35]	Remote Call Forwarding / Mobile Twinning [38]
Backup Failure Alarm [31]	Extension Name Display [35]	Ringing Line Preference [38]
Backup Programming Automatic [31]	Fax Machine Extensions [35]	Ring on Transfer [38]
Backup Programming Manual [32]	Feature Button	SMDR
Bridging (Joining Calls) [32]	Group Calling – Ring/Page [36]	Speed Dial Features [39]
Call Coverage [32]	Group Hunting – Ring/Voice Signal [36]	Station Lock/Unlock [39]
Call Forwarding/Follow Me(Intercom) [32]	Group Pickup [36]	System Password [39]
Call Log (Digital Sets only) [32]	Hold [36]	System Groups [39]
Call Logs (ETR sets) [32]	Hold Release on Abandon	Transfer / Transfer Return [39]
Call Pickup [32]	Hold Reminder Tone [36]	VMS Cover Button [40]
Call Timer [32]	Hot Dial [36]	VMS Cover Ring Interval [40]
Call Timer Continuity	Hotline [36]	VMS Hunt Delay [40]
Call Waiting [133]	Idle Intercom Timeout	VMS Hunt Schedule [40]
Caller ID Features [33]	Intercom Manual Dial [37]	Voice Mailbox Transfer – Direct [40]
Cell Phone Connect (see Mobile Twinning) [33]	Intercom Dial Tone [36]	Voice Messaging [40]
Centralized Telephone Programming (from admin phones) [42]	Line Coverage Extension [37]	Visual Messaging [40]
CO Disconnect Time (Programmable) [33]	Line Ringing Options [37]	Voice Mail to e-mail

Feature description can be found on the following pages. TUI Feature Programming Codes (if applicable) are also provided.

911 Emergency Dialing

911 Emergency Dialing can be made from any extension, regardless of any restrictions.

Abbreviated Ringing (#305)

This feature activates or deactivates Abbreviated Ringing at the system telephone at a specific extension. When you are on a call and Abbreviated Ringing is Active, any incoming call rings only once. The green light next to the line button flashes until the call is answered or the caller hangs up (or for a transferred call, until the call returns to the transfer return extension).

This feature prevents incoming calls from distracting you when you are busy on another call. To allow calls to ring repeatedly, set Abbreviated Ringing to Not Active.

Absent Text Messaging (FEATURE 28)

This feature allows you to post a message (such as "Do Not Disturb" or "Away from desk") on the display of your PARTNER ETR or DS system phone. When another extension calls your extension, your active Absent Text Message appears on the caller's display.

The system provides 15 pre-defined messages, plus 2 that may be customized by each user. Pre-defined messages include:

Back Soon	Back Tomorrow	Do Not Disturb
On Vacation	Out to Lunch	At Home
Away from Desk	Be Right Back	Please Call
On Holiday until	Meeting until	Don't disturb until
With visitors until	With cust. til	At lunch until

Account Code Entry (FEATURE 12)

Account Code Entry (ACE) is used to enter an account code (up to 15 digits) for an incoming or outgoing call currently being handled.

The Account code is printed in the SMDR record for the call for the customer to use for cost tracking purposes.

There are two different ways the feature can be used:

- Voluntary — Account Code Entry is optional.
- Forced – Account Code Entry is mandatory before dialing on an idle CO facility.

Forced account codes are validated against a list of pre-defined account codes which is created via the Manager application.

Allowed Lists(#407) / Disallowed Lists (#404)

Allowed Lists Use this feature to specify telephone numbers that users can dial regardless of other dialing restrictions, as long as they have access to an outside line. For example, if you restrict an entire category of calls through Disallowed Phone Number Lists (#404), you can permit calls to a specific number in that category by placing that number on an Allowed Phone Number List.

You can create up to eight Allowed Phone Number Lists of up to 10 telephone numbers each.

Disallowed Lists allow you to specify telephone numbers that users cannot dial. For example, you may want to prevent calls to a specific telephone number or to categories of numbers, such as international numbers.

You can create up to eight Disallowed Phone Number Lists of up to 10 telephone numbers each.

Allowed and Disallowed Phone Numbers can be up to 12 digits long and may include 0–9, #, *, and 'hold' (a wildcard character, displayed as "!").

Attendant Positions

Extension 10 and Extension 11 serve as system attendant positions. TUI System Administration can only be done at these extensions. Night Service and Unlock capabilities can only be initialized from Extension 10. When a user dials 0, Extension 10 will ring.

Auto Dialing

Enables you to dial outside numbers, extension numbers, feature codes or account codes with a single touch by pressing a programmed button.

3 types of auto dial are supported:

- Auto Dial – Outside
- Auto Dial – ICM (internal extension)
- Auto Dial – ICM Page (voice signaling)

Automatic Callback

When calling an extension that is busy, press the Auto Callback softkey and the system will call you when the extension becomes free.

Automatic Daylight Savings Time (#126)

This feature automatically updates the system clock for annual Daylight Savings Time and Standard Time changes. Turn this feature off if you live in an area without daylight savings time.

Automatic Extension Privacy (#304)

Prevents other extensions with access to the same line from joining a call from their extension. Use this feature for extensions connected to a modem, fax, or any device whose function can be disrupted by someone trying to join it.

Automatic Line Selection

Specifies the order in which the system selects an available line (intercom or outside) when a user at the extension lifts the handset or presses SPEAKER to make a call without first selecting a specific line button.

For extensions with analog telephones, set Automatic Line Selection to intercom first. This enables analog telephones to access system features, including intercom calling. When users lift the handsets on analog telephones, they hear intercom dial tone. To access an outside line, they must dial 9.

Automatic Voice Mail Coverage (#310)

Use this feature to program a button to turn VMS Cover on and off, routing unanswered intercom and transferred calls for a users' extension to the Call Answer Service of the voice messaging system after the specified number of rings (factory setting is three rings).

Backup Failure Alarm

When an Automatic Backup fails, a 'Backup Failed' message is displayed on Extension 10 and 11.

Backup Programming - Automatic

The PARTNER Version does a nightly backup to the system SD card. No manual intervention or external PC is required.

Backup Programming - Manual (#124)

The administrator may do a manual system programming backup to the system SD card via the TUI.

Bridging (Joining Calls)

A user can bridge (join) on any active call by pressing the associated CO line button (assuming Privacy is not active on the originating extension.) When a call is bridged, the red and green LED's will alternate on all telephones which are bridged on the call.

Call Coverage (FEATURE 20)

This feature is used to redirect all Intercom, Transferred, DID and outside calls from a user's extension to another extension.

When Call Coverage is activated, covered calls are routed to the covering extension after a specified number of rings.

Call Forwarding / Follow-Me (FEATURE 11)

The Call Forwarding and Follow Me features both provide a means of redirecting Intercom (ICOM), CO, and Transfer calls from one extension to another specified extension.

Call Forwarding is the feature used by extensions to send their calls to another extension. Follow-Me is the feature used by extensions to pull calls in from another extension.

Call Log - Digital Sets

Call Log is a fixed button on digital telephones and provides a visual record of calls made and received, including unanswered calls. Details are store for both users (maximum 30 entries) and hunt groups (maximum 10 entries). The method of operation varies according to the phone type but in all cases the call records can be used for return calls.

Call Logs - ETR sets (#317)

Use this feature to program extensions to log answered Caller ID calls so that calls answered at an individual extension can be viewed in the Caller ID Call Log. Once the feature is activated for an extension, when a user activates the Caller ID Call Logging and Dialing (F23), all Caller ID calls that are answered by that extension are logged.

Up to 3 extensions can be designated to log all calls, both answered and unanswered, regardless of where they terminated in the system.

Call Pickup (INTERCOM 6xx)

This feature is used to answer any intercom, transferred or outside call ringing at another specified extension.

Call Timer Display

Displays the duration of a call from the time it was answered.

Call Waiting

Call waiting applies to analog, single line telephones, and applies to the following types of calls:

- Intercom calls
- Transferred calls
- Forwarded calls
- Covered calls
- Outside calls (if the extension has a line appearance of the line)
- Voice Signaled calls

Caller ID Features

The following Caller ID features are supported:

- Caller ID Inspect (FEATURE 17)
Allows you to view Caller ID information for a second call, without disconnecting the current call or putting it on hold. Use this feature to inspect ringing, active, or held calls.
- Caller ID Name Display (FEATURE 16)
When an incoming call is ringing at a display telephone, both the name and number appear on the user's display. The Number is displayed on the top line, and the Name on the 2nd line. In some cases users may wish to see the Caller ID Name on the top line and the Caller ID Number on the 2nd line. This feature provides this capability.

Cell Phone Connect

See [Mobile Twinning](#) ³⁸.

CO Disconnect Time (Programmable)

Use this feature to change the hold disconnect time for an outside line. Different telephone companies use different length signals. The length of the signal is called the CO or Hold Disconnect time. If you place a call on hold and the caller hangs up, but the call does not disconnect within a minute after the caller.

Conference Drop

On 14xx digital telephones, you may choose which specific party you want to drop from a conference call. On ETR and analog telephones, the last party added to the conference call is automatically dropped.

Conferencing

PARTNER Version supports up to 64-party conferencing. A maximum of 2 analog lines can be in any conference call. Conference calls may consist of combinations of analog lines, digital lines (PRI/T1, SIP), analog phones, ETR phones or digital phones.

Contact Closure Support for 2 Devices (FEATURE 41 and FEATURE 42)

The IP500 v2 Control Unit has a Contact Closure control jack on the back panel. This is a 3.5 mm stereo jack that can drive two external adjunct relays.

This feature allows users at eligible extensions to control an external adjunct by entering feature codes at their system or standard telephone. The port can control a variety of devices, the most common being door strikes, night bells, lighting, or voice recording systems.

Copy Settings (#399)

This feature allows a System Administrator to copy extension-specific programming from one extension to another. When the Extension Copy operation is performed, the destination extension will have the same properties as the originating extension.

Extension Copy can only be performed from an Attendant Extension in System Programming Mode or from the Windows Manager PC application.

Dial Code Features

- 'F' represents the FEATURE button.
- 'I' represents the INTERCOM button.
- 'XX' represents a system extension number.
- 'PP' represents a Personal Speed Dial code.
- 'G' represents a single-digit group number.
- 'LL' represents a system line number.

Dial Code	Feature
F01	Do Not Disturb
F03	Recall
F04	Save Number Redial
F05	Last Number Redial
F06	Conference Drop
F07	Privacy
F11	XX,XX Call Forwarding/Call Follow-Me
F11	XX,*PP Cell Phone Connect
F11	XX,PP Remote Call Forwarding
F12	Account Code Entry
F14	Voice Mailbox Transfer
F15	VMS Cover
F16	Caller ID Name Display
F17	Caller ID Inspect
F20	XX,XX Call Coverage
F21	Station Lock
F22	Station Unlock
F23	Caller ID Call Logging and Dialing
F26	Hot Dial
F28	Absent Text Message
F41	Contact Closure 1
F42	Contact Closure 2
F59	System Release

Direct Inward Dialing (DID)

Use this feature to have Direct Inward Dialing (DID) numbers on a PRI / T1 or SIP line routed automatically to a specific extension, hunt group, or calling group. When a Direct Inward Dialing (DID) call arrives, the PARTNER system "collects" the digits from the T1 service provider (that is, the number that was dialed) and matches the number to a DID Mapping Table you created. If the incoming number matches an entry in the DID Mapping table, the call rings at the matching extension or hunt group.

Direct Line Pickup (INTERCOM 68LL, INTERCOM 8LL)

With the Direct Line Pickup features, you can access a ringing or held call or a call in progress. You can also select a line to use that is not assigned to your telephone. The Direct Line Pickup features are:

- Direct Line Pickup—Active Line
- Direct Line Pickup—Idle Line

Display Language

All system telephones offer the choice of 3 display language:

- US English
- Canadian French
- Latin American Spanish

Each individual extension may select their own language.

Distinctive / Differentiated Ringing

PARTNER Version provides different ring patterns for external calls, internal calls and transferred calls.

Do Not Disturb (FEATURE 01)

Use this feature to be able to press a programmed button to prevent incoming calls for the extension from ringing (lights still flash). When Do Not Disturb is on, outside callers hear ringing while inside callers hear a busy signal. Calls are immediately sent to your voice mailbox.

Doorphones

A doorphone is usually placed near an entrance, to screen visitors. You can connect up to two doorphones to the system.

Emergency Phone Number List (#406)

Create a list of up to 10 telephone numbers that all users can dial regardless of dialing restrictions, provided they have access to an outside line. Typical list entries include fire, police, and emergency services numbers.

Extension Hunt Groups (#505)

Use this feature to assign any number of extensions to a Hunt Group. When extensions are in a Hunt Group, an incoming call searches or "hunts" for the longest idle extension that is available. The system supports up to six Hunt Groups

Extension Hunt Groups (#505)

Use this feature to assign any number of extensions to a Hunt Group. When extensions are in a Hunt Group, an incoming call searches or "hunts" for the longest idle extension that is available. The system supports up to six Hunt Groups.

Extension Name Display

The user's name and extension number is displayed on the display telephone.

External Hotline (#311)

When a user lifts the handset of an external hotline, a predetermined outside number is dialed automatically. The external number might be, for example, a frequently called service bureau. The external hotline must be a single line telephone, not a system telephone, and should not have a dial pad.

Fax Machine Extensions (#601)

Allows you to connect your fax machine to your system, allowing you to share network facilities.

Group Calling - Ring / Page (INTERCOM 7G / INTERCOM *7G)

Use this feature to ring, page, or transfer calls simultaneously to all of the extensions in any one of four Calling Groups. (G represents a Calling Group number from 1–4.) When paging, you hear a beep and can begin speaking. Your voice is heard on the speakers of all idle system telephones in the selected Calling Group. The first extension to answer the call (on ETR sets - by picking up the handset or pressing SPEAKER, on 14xx sets - or by pressing the ANSWER softkey on the display) is connected to the caller.

You can group page employees for general announcements; this is an inexpensive alternative to a paging system.

Group Hunting - Ring / Page (INTERCOM 77G / INTERCOM *77G)

Use this feature to distribute call volume among extensions in a group, to off-load call activity from a single user. When an intercom or transferred call is placed to a Hunt Group (where G is a Hunt Group number from 1–6), the system rings or voice-signals the first available extension in the group, passing over busy extensions (or those with Do Not Disturb on) in a circular hunt. If a ringing call is not answered within three rings, the call moves to the next available extension, and so on, until the call is answered or the caller hangs up.

For a voice-sigaled call, only the first available extension is signaled; if that extension does not answer, the call does not keep hunting. After an extension receives a Hunt Group call, the next call to the Hunt Group will not ring or voice-signal that extension first unless all other extensions in the group are busy or do not answer.

Group Pickup (INTERCOM 66G)

Use this feature to answer any outside, intercom, or transferred call ringing at an extension in a Pickup Group (where G is a Pickup Group number from 1–4). When a call rings at an extension that is in a Pickup Group, you can answer the call at any extension without knowing which extension or line is ringing and without being in the same Pickup Group. The system can have up to four Pickup Groups.

Hold Reminder

If a call is left on hold for longer than a specified period, the extension will ring back, alerting you that the call is still on hold. This ring continues to sound until the held call is retrieved, or until the caller hangs up.

Hot Dial

This feature enables a user to start dialing a number without first pressing the speaker button or going off-hook.

Hotline

This feature allows designated extensions to automatically place an intercom call to another designated extension, when it goes off-hook.

Intercom Dial Codes

- 'I' represents the INTERCOM button.
- 'XX' represents a system extension number.
- 'G' represents a single-digit group number.
- 'LL' represents a system line number.

Intercom Dial Code	Feature
I 6XX	Call Pickup
I 66G	Group Pickup
I 68LL	Direct Line Pickup—Active Line
I 70	Loudspeaker Paging
I *70	Simultaneous Paging
I 7G	Group Calling—Ring
I *7G	Group Calling—Page

Intercom Dial Code	Feature
I 77G	Group Hunting—Ring
I * 77G	Group Hunting—Voice Signal
I 8LL	Direct Line Pickup—Idle Line

Intercom Dial Tone (#309)

Use this feature to determine the type of dial tone that the system provides at an extension. It may be necessary to change this setting to Machine (outside line) dial tone for an autodialing device, such as a fax or modem, that has trouble making calls. For example, if you have a modem that checks for outside line dial tone before dialing, use this procedure to change from Regular to Machine dial tone.

Intercom Manual Dialing

Users can make an internal call to another extension by ringing it (dialing its extension number) or voice signaling the extension by prefixing the extension number with a *.

Line Coverage Extension (#208)

Use this feature to identify an extension as the "owner" of a specific outside line, so the extension can activate Call Coverage or VMS Cover for that line.

Line Ringing Options

This feature specifies the options: Immediate Ring, Delayed Ring or No Ring for incoming calls on a line appearance programmed on the extension.

Log All Calls

Up to 3 extensions can be designated to log all calls, both answered and unanswered, regardless of where they terminated in the system.

Music on Hold

Connect an audio source to the Music-On-Hold port on the processor module so that a caller hears music when placed on hold when the Music-On-Hold feature has been activated.

Network Time Synchronization (#128)

Use this feature to specify whether you want to synchronize the system clock with the network time delivered by your service provider over Caller ID. If Network Time Synchronization is set to Active, the system will use the network time provided by your service provider; if it is set to Not Active, the system will use the time provided by its system clock.

Night Service

When Night Service is on and a call comes in, all extensions in the Night Service Group ring immediately, regardless of normal Line Ringing settings.

Paging Features (INTERCOM 70 and INTERCOM *70)

- Loudspeaker Paging - Users can initiate a call (either manually dialed or intercom auto dialed) to an extension connected to an analog station port that connects them to an external loudspeaker paging system.
- Simultaneous Paging is a feature that pages both the external loudspeaker paging system (via the paging port) as well as voice signals all of the extensions in Calling Group 1.

Personal Line Termination

Allows you to assign a line / lines to specific extension / extensions.

Personalized Station Ringing (#323)

Allows you to assign a personalized ring pattern to an extension

POTS (Plain Old Telephone Set) Support

POTS (single line analog telephones) are supported on the system. They are connected to an analog station port on the Combo module; a port on the Phone-2, Phone-8 or Phone-16 module, or to an ETR port.

Privacy (FEATURE 07)

Privacy prevents other users from joining on your call.

Recall (FEATURE 03)

Use this feature to send a timed switch hook flash over the telephone line to "recall" a new dial tone or to access certain central office features, such as Call Waiting or 3-way calling.

Redialing Features

There are 2 features which offer redial functionality:

- Last Number Redial (FEATURE 05): Last Number Redial redials all digits dialed on the last outside call except account codes.
- Save Number Redial (FEATURE 04): Saves into temporary memory the last outside number (up to 28 digits) dialed from a system telephone. Use this feature to save a number before you hang up on a busy or unanswered call. Once saved, the number can be redialed at any time. The number stays in memory until a different one is saved.

Remote Call Forwarding / Mobile Twinning

There are two types of Remote Call Forwarding supported on PARTNER Version:

1. Remote Call Forwarding (FEATURE 11) allows a user to send internal and external calls destined for a particular extension to an external phone number (off the system) over an analog trunk. Remote Call Forwarding will not alert the internal extension, but immediately sends the call out to the predefined number.
2. Mobile Twinning allows a user to send internal and external calls destined for a particular extension to an external phone. The call simultaneously rings at the internal extension and receives the extension's coverage (including Voicemail) treatment if the call has not been answered. This feature is only available on systems that have digital trunks (SIP, PRI/T1).

Ring on Transfer (#119)

This is used to specify what the caller hears while they are being transferred. If Ring on Transfer is set to Active, callers hear ringing while they are being transferred; if it is set to Not Active callers hear beeps or Music on Hold if this is activated and a music source is connected to the system.

Ringling Line Preference

When an extension is on-hook and the extension is ringing, the user simply goes off-hook to answer the call and is automatically connected to the ringing call. If more than one call is alerting, the system automatically connects the user to the longest ringing call.

Speed Dial Options

PARTNER Version supports the following types of Speed Dialing:

- **Personal Speed Dial (FEATURE 80 – 99)**
Each user can store up to 20 frequently-dialed numbers in their extension. Personal Speed Dial numbers can be dialed quickly by pressing FEATURE (or # at intercom dial tone on a single-line telephone) and the two-digit speed dial code from 80 through 99. The Personal Speed Dial numbers programmed for a particular extension are for use only at that extension.
- **System Speed Dial (FEATURE 600 – 699)**
System Speed Dialing is a shared list of up to 100 frequently-dialed numbers up to 28 characters in length. All users on the system may dial a System Speed Dial number by pressing FEATURE (or # at intercom dial tone on a single-line telephone) and the three digit speed dial code, from 600 through 699

Station Lock / Unlock (FEATURE 21)

Station Lock helps to prevent unauthorized people from making outside calls from extensions. Users enter a four-digit code on their telephone dialpad to “lock” your extension. To unlock the phone, the user enters the identical code.

Station Message Detail Reporting (SMDR)

SMDR is a call reporting feature that provides records of call activity. It is commonly used in many types of business, including Legal, Contact Centers, Sales and Real Estate. **Call reporting information allows users to:**

- Detect any unauthorized calls.
- Bill clients or projects.
- Bill back by department.
- Reduce telephone costs by identifying the need to change telecommunications services
- Print Caller ID information.

The output is generally sent to a PC running an optional Call Accounting software package.

System Groups

PARTNER Version supports the following types of groups:

- **Pickup Groups (4 Groups) (INTERCOM 6xx)**
When a call rings at an extension assigned to a Pickup Group, a user at any other extension in the system can answer the ringing call by dialing the Pickup Group code. The Pickup Group feature helps when a user needs to answer calls on lines or pools not assigned to his or her telephone.
- **Calling Groups (4 Groups) (INTERCOM 7x / *7x)**
A Calling Group is a group of extensions that can be called at the same time. Any user in the system can ring or page all extensions in a Calling Group at the same time or transfer a call to a Calling Group. The first extension to pick up the call is connected to the caller. A typical use of this feature is to have callers ring into a Calling Group of sales representatives, or to create a “Page All” group.
- **Hunt Groups (6 Groups) (INTERCOM 77G / *77G)**
When extensions are in a Hunt Group, an incoming call searches or “hunts” for the first available extension.
- **Night Service Group (1 Group) (#504)**
When Night Service is activated and a call comes in, all extensions assigned to the Night Service Group ring immediately, regardless of normal Line Ringing settings.

System Password (#403)

Allows you to define a four-digit password that users can enter from PARTNER telephones to override dialing restrictions (if the extension has access to an outside line) or turn Night Service on and off.

Transfer / Transfer Return

You can transfer calls to an extension or group using the TRANSFER button on a system telephone or the switchhook on a single-line telephone.

Transferred calls return to the originating extension if they are not answered. You also can program the number of times a transferred call rings before it returns to an extension.

Visual Voice Messaging

Supported on 14xx digital telephones only. Allows the user to manage their voice mail messages via their display. Features supported include:

- access new /old / saved messages.
- next and previous message.
- fast forward and rewind.
- pause message.
- save, delete and copy message to other users of the system.
- change default greeting.
- change password.

VMS Cover (FEATURE 15)

Allows you to turn VMS Cover on and off, routing unanswered intercom and transferred calls for users extensions to the Call Answer Service of the voice messaging system after the specified number of rings

VMS Cover Ring Interval (#321)

Allows you to define the number of times a call rings before it is sent to a user's voice mailbox.

VMS Hunt Delay (#506)

Allows you to determine when outside calls should be answered by the Automated Attendant of the voice messaging system. You can set the system for any number of rings, 0–6. Assigning more rings gives the operator an opportunity to answer calls before they go to the Automated Attendant.

VMS Hunt Delay is programmable on a per-line basis. In addition, you can program this feature so that calls can be handled one way during the day and a different way when the system is in Night Service.

VMS Hunt Schedule Interval (#507)

Allows you to determine when outside lines are covered by the Automated Attendant. Options include all the time, only during Day operation (Night Service is off), or only during Night operation (Night Service is on).

Voice Mailbox Transfer - Direct (FEATURE 14)

Allows you to transfer a call directly into a users voice mailbox without ringing their extension.

Voice Messaging

The PARTNER Version has Embedded Messaging included in the system. All extensions are automatically assigned a mailbox.

Embedded Messaging also provides:

- A 2-port, single level Automated Attendant
- Separate Morning, Afternoon, Evening and Out of Hours menu greetings with time profiles
- Dial by Name capability
- 15 hours of storage
- Up to 3 minutes per message
- Fast Forward, Rewind, Replay and Skip capability
- Voice Mail to e-mail capability

- Remote message retrieval
- Visual Messaging (on Digital telephones only)

Application Programming Interface (TAPI)

Application Programming Interface (TAPI) allows new and existing server-based applications from Avaya's Developer Connection (DevConnect) program to work with and enhance the operation of the PARTNER Version system. The current requirement is to support a screen pop type application called "Pickup IP" which is also supported on IP Office.

The TAPI API only supports 1st Party TAPI applications.

System Programming Procedures

Code	Feature	Code	Feature
# 101	System Date	# 321	VMS Cover Rings
# 103	System Time	# 322	Remote Call Forwarding
# 104	Number of Lines	# 323	Personalized Station Ringing
# 105	Transfer Return Rings	# 399	Copy Settings
# 107	Recall Timer Duration	# 401	Outgoing Call Restriction
# 109	Outside Conference Denial	# 402	Toll Call Prefix
# 119	Ring on Transfer	# 403	System Password
# 123	Backup Programming—Automatic	# 405	Disallowed List Assignments
# 124	Backup Programming—Manual	# 406	Emergency Phone Number List
# 125	Restore Programming	# 407	Allowed Phone Number Lists
# 126	Automatic Daylight/Standard Times	# 408	Allowed List Assignments
# 127	Hold Reminder Tone	# 409	Forced Account Code List
# 128	Network Time Synchronization	# 501	Pickup Group Extensions
# 203	Hold Disconnect Time	# 502	Calling Group Extensions
# 205	Direct Extension Dial Lines	# 503	Night Service Button
# 206	Group Call Distribution	# 504	Night Service Group Extensions
# 208	Line Coverage Extension	# 505	Hunt Group Extensions
# 301	Line Assignment	# 506	VMS Hunt Delay
# 303	Display Language	# 507	VMS Hunt Schedule
# 304	Automatic Extension Privacy	# 601	Fax Machine Extensions
# 305	Abbreviated Ringing	# 602	Music-On-Hold
# 306	Transfer Return Extension	# 603	Hotline
# 307	Forced Account Code Entry	# 604	Doorphone Extension 1
# 308	Distinctive Ring	# 605	Doorphone Extension 2
# 309	Intercom Dial Tone	# 606	Doorphone Alert Extensions
# 310	Automatic VMS Cover	# 610	SMDR Output Format
# 311	External Hotline	# 612	Contact Closure Group
# 316	Call Waiting	# 613	Contact Closure Operation Type
# 317	Caller ID Log Answered Calls	# 617	Loudspeaker Paging Line
# 318	Caller ID Call Log Line Association	# 728	System Reset—Programming Saved
# 320	Call Coverage Rings	# 730	Remote Administration Password

Centralized Telephone Programming

Extensions 10 and 11 can program other extensions on the system from their telephones.

Chapter 3.

IP Office Platform

3. IP Office Platform

IP Office is a modular communications solution that scales from 2 to 384 extensions. It provides a hybrid PBX with both Time Division Multiplexing (TDM) and IP phone support that can be used in either mode or both concurrently. IP Office has data capabilities built in, providing IP routing, switching and Firewall protection between LAN and WAN. IP Office has a web based applications suite that delivers contact center reporting, voice and email messaging, Interactive Voice Response, conferencing and computer telephony integration.

IP Office solutions are built from hardware units and application software. Hardware provides the connectivity for voice and data circuits and processor units for the solution software. Each IP Office solution will require a system control unit (IP500 or IP500 V2), trunk connections to service provider, and expansion modules for TDM phone cabling. IP Phones connect over LAN connections to the IP Office solution.

IP Office Control Unit

With Release 6 a new control unit IP Office 500 V2 (IP500 V2) will be launched. The existing IP Office 500 control unit (IP500) will be phased out in the near future. The IP500 V2 control unit is compatible with all IP500 base extension and VCM cards as well as all external IP500 expansion modules.

The IP500 and IP500 V2 are stackable units with an optional 19" rack mounting kit and an optional wall mounting kit for smaller configurations. They provide:

- 4 slots to house a mixture of extension cards and VCM cards:
 - Digital Station 8 card.
 - Phone 2 and Phone 8 cards.
 - VCM-32 and VCM-64 cards.
 - 4-Port Expansion card.
 - ETR 6 port phone card. (IP500 V2 only, North America only)
 - Combination Card with 10 VCM channels, 4 analog trunks, 6 Digital Station (DS) and 2 Phone ports. (IP500 V2 only)
 - Combination Card with 10 VCM channels, 2 BRI trunk interfaces (4 channels), 6 Digital Station (DS) and 2 Phone ports. (IP500 V2 only)
- Optional trunk daughter card support:
 - Analog Trunk Module 4 card.
 - BRI-4 and BRI-8 cards (2 x 2B+D and 4 x 2B+D channels respectively).
 - Single and Dual Universal PRI cards.
 - Support for IP400 trunk and VCM cards using a Legacy Card Carrier.
- IP500: Slot for smart card Feature Key – required for system operation as well as licensing of optional features.
- IP 500: Slot for Compact Flash card – used for embedded messaging as part of Essential Edition.
- IP500 V2 : 2 Slots for SD cards (System and optional) – System SD card is required for system operation as well as licensing of optional features and storage for embedded voicemail in Essential Edition.
- 9-pin DTE Port for maintenance.
- Support for up to 12 IP500 Expansion Modules:
 - Phone modules (16, 30).
 - Digital Station modules (16, 30).
 - Analog Trunk Module 16.
 - BRI So8 module.
 - IP400 expansion modules (not WAN3 10/100 or Network Alchemy modules)
- External output socket supporting two relay on/off switch ports, e.g. for door entry systems.
- Audio input port for external music on hold source.
- 48 Data channels.
- Up to 40 VoiceMail Pro ports.
- Two 10/100 switched Ethernet ports (Layer 3).

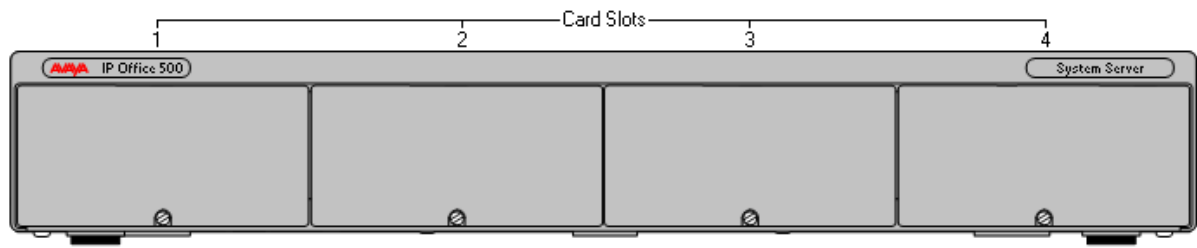

IP500 and IP500 V2 Front View

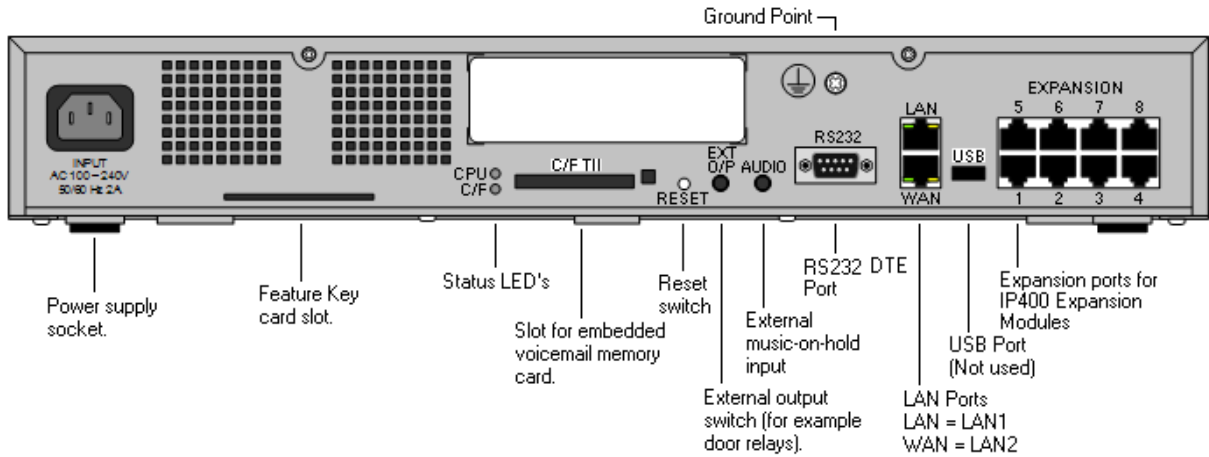

IP500 Back View

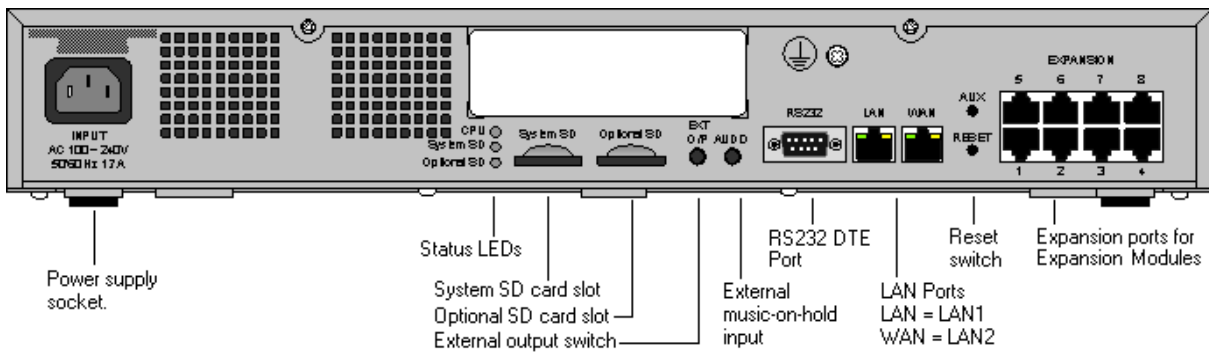

IP500 V2 Back View

IP500 Base Cards

The IP500 control unit has 4 slots for the insertion of cards. These cards can be divided into two types; base cards and daughter cards. Base cards include a front panel and ports for cable connections. Daughter cards can be added to a base card in order to provide additional facilities (typically trunk connections).

The following base cards are available:

- [IP500 Digital Station 8 Card](#) ^[48] (Maximum 3)
- [IP500 Analog Phone 2 Card and Phone 8 Card](#) ^[48] (Maximum 4)
- [IP500 VCM Card](#) ^[50] (Maximum 2)
- [IP500 4-Port Expansion Card](#) ^[51] (Maximum 1)
- [IP500 Legacy Card Carrier](#) ^[51] (Maximum 2)
- [ETR 6 Port Phone Card](#) ^[49] (Maximum 3, IP500 V2 only)
- [Combination Card with 2 Analog Trunks](#) ^[49] (Maximum 2, no daughter card, IP500 V2 only)
- [Combination Card with 2 BRI Trunks](#) ^[50] (Maximum 2, no daughter card, IP500 V2 only)

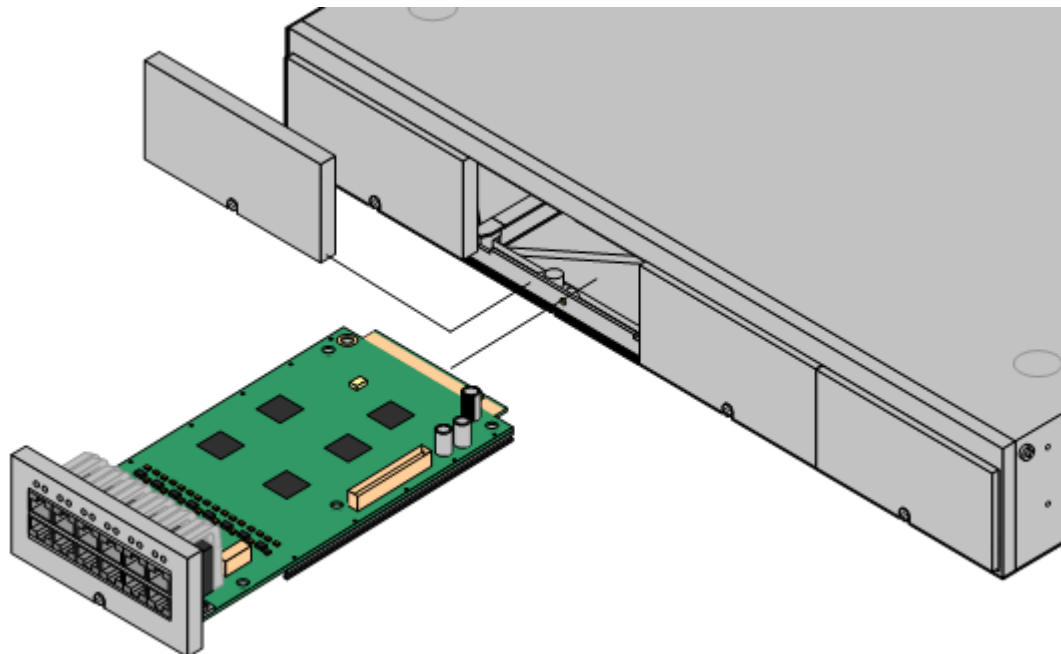

IP500 Digital Station 8 Card

This card provides 12 RJ45 ports. The first 8 ports are DS ports for the connection of Avaya digital phones other than IP phones. The card can be fitted with an IP500 daughter trunk card, which then uses the additional 4 RJ45 ports for trunk connections.

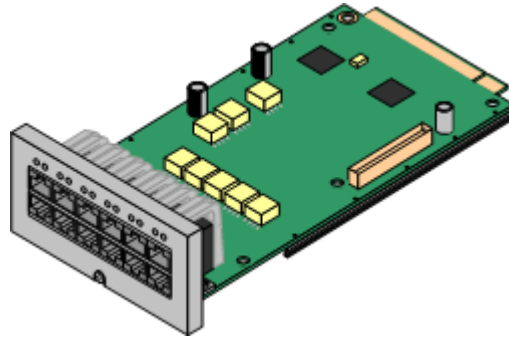

- This card accepts one IP500 trunk daughter card of any type.
- This card supports selected Avaya 2400, 5400 and 6400 Series phones, plus T3 phones(EMEA only) and 3810 wireless phones (North America only).
- 4400 Series phones (4406D, 4412D and 4424D) are not supported on this card, only on Digital Station expansion modules. Therefore a maximum of 360 x 4400 Series phones are supported in the system.

IP500 Analog Phone 2 Card

This card provides 2 analog extension ports (1-2) for the connection of analog phones. The card can be fitted with an IP500 daughter trunk card, which then uses the last 4 RJ45 ports (9-12) for trunk connections.

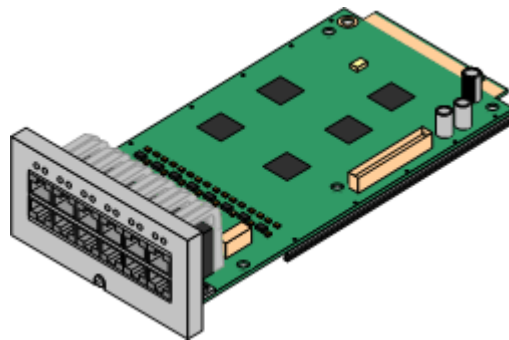

- This card accepts one IP500 trunk daughter card of any type.

IP500 Analog Phone 8 Card

This card provides 8 analog extension ports for the connection of analog phones. The card can be fitted with an IP500 daughter trunk card, which then uses the additional 4 RJ45 ports for trunk connections.

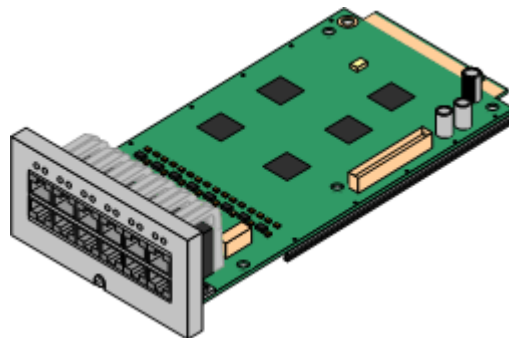

- This card accepts one IP500 trunk daughter card of any type. When fitted with an Analog Trunk daughter card, it provides a single power-fail port.

IP500 ETR 6 port Phone Card

This card provides 6 ETR ports for the connection of ETR 6/18/34 D, Euro-Style and Refresh digital phones as well as 3910/3920 wireless phones. The card can be fitted with an IP500 daughter trunk card, which then uses the additional 4 RJ45 ports for trunk connections. A maximum of three of these cards is allowed in the IP500 V2 chassis.

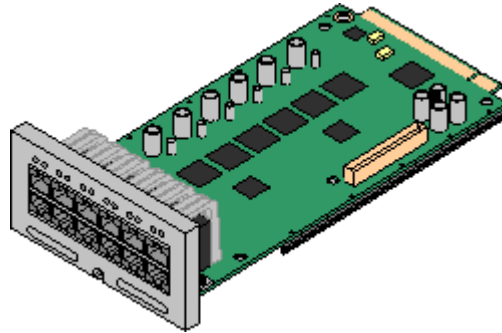

This card

- accepts one IP500 trunk daughter card of any type. When fitted with an Analog Trunk daughter card, it provides a single power-fail port.
- works in IP500 V2 only.
- is only supported by the IP Office Essential Edition - PARTNER Version (please see chapter 1b).

IP500 Combination Card with 4 Analog Trunks

This card works in the IP500 V2 only and provides:

- 4 analog trunk ports.
- 2 analog extension ports for the connection of analog phones.
- 6 Digital Station (DS) ports for the connection of Avaya digital phones.
- 10 VCM channels to support IP telephones or voice networking.

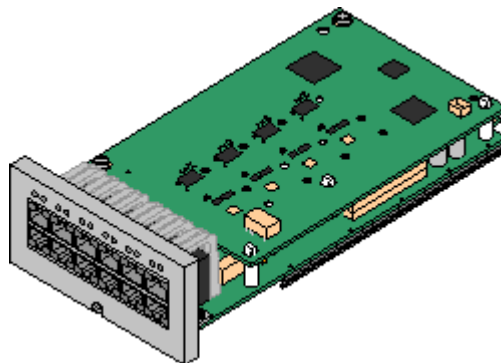

This card already includes a IP500 trunk daughter card, therefore no additional daughter card is possible. It provides a single power-fail port (either port 7 or port 8). A maximum of two of these cards is allowed in the chassis.

IP500 Combination Card with 2 BRI trunks

This card works in the IP500 V2 only and provides

- 2 BRI trunk ports (4 channels).
- 2 analog extension ports for the connection of analog phones.
- 6 Digital Station (DS) ports for the connection of Avaya digital phones
- 10 VCM channels to support IP telephones or voice networking

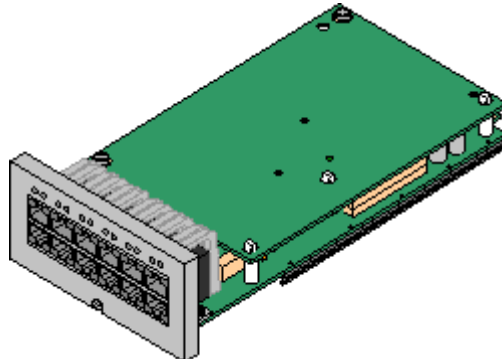

This card already includes a IP500 trunk daughter card, therefore no additional daughter card is possible. it provides a single power-fail port (either port 7 or port 8). A maximum of two of these cards is allowed in the chassis.

IP500 VCM Card

This card provides voice compression channels for use with VoIP calls, SIP trunks and IP-based voice networking. The module is available in variants supporting 32 or 64 channels.

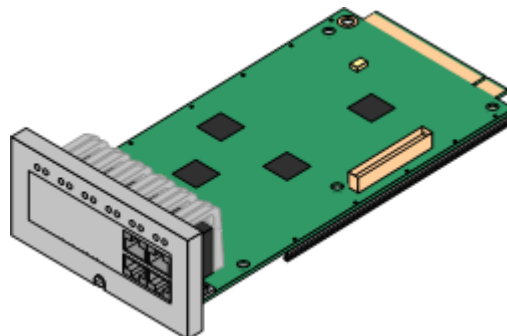

The maximum number of voice compression channels supported, using IP500 VCM base cards, Combination Cards and / or IP400 VCM cards on IP500 Legacy Card Carriers, is 148.

Please note, the maximum number of channels which may be used on each IP500 VCM card varies according to the codec used, as shown in the following table.

Maximum VCM channels available, by codec type:

	VCM 32 Card	VCM 64 Card	Combination Card
G.711	32	64	10
G.729	30	60	10
G.723	22	44	10

The card can be fitted with an IP500 daughter trunk card, which uses the 4 RJ45 ports for trunk connections.

- This card accepts one IP500 trunk daughter card of any type.

For more details about VCM channel requirements please refer to [IP Telephony](#) ^[158].

IP500 4-Port Expansion Card

- This card provides connectors for 4 additional expansion modules.
- The 4-port expansion card must be inserted in slot 4 of the control unit.
- It is not possible to connect a daughter card to the 4-port expansion card.

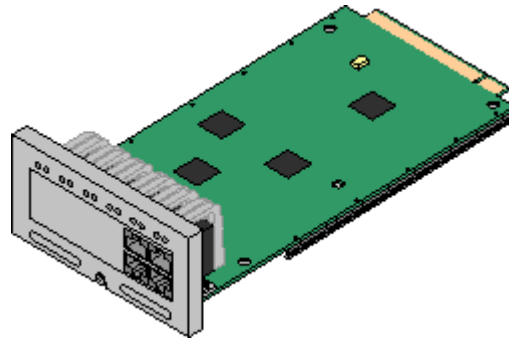

IP500 Legacy Card Carrier

This card allows a variety of IP400 trunk and VCM cards to be used with the IP500 control unit. The front of the card includes a number of panels that can be snapped off to match the ports available when an IP400 trunk card is fitted.

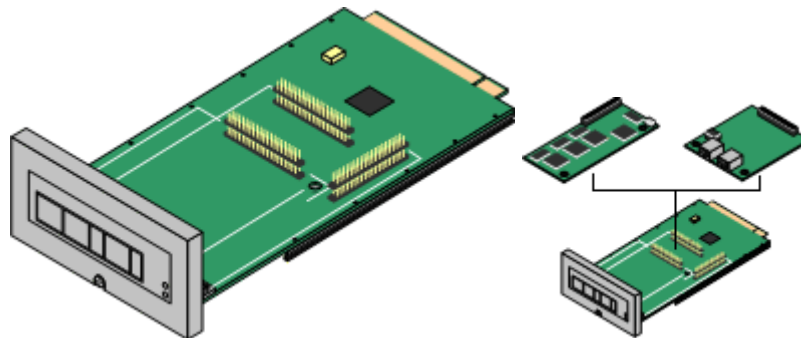

- This card does not accept any IP500 daughter trunk cards.
- The IP500 control unit can accept up to 2 IP400 trunk or VCM cards by mounting each card on an IP500 Legacy Card Carrier
- This card supports the following IP400 cards:
 - ✓ PRI T1
 - ✓ Dual PRI T1
 - ✓ PRI 30 E1 (1.4)
 - ✓ Dual PRI E1
 - ✓ PRI 30 E1R2 RJ45
 - ✓ Dual PRI E1R2 RJ45
 - ✓ ANLG 4 Uni
 - ✓ BRI-8 (UNI)
 - ✓ VCM 4
 - ✓ VCM 8
 - ✓ VCM 16
 - ✓ VCM 24
 - ✓ VCM 30

IP500 Trunk Cards

IP500 daughter trunk cards can be fitted to existing IP500 base cards to provide support for trunk ports. The daughter card uses the ports provided on the base card for cable connection. The addition of an IP500 daughter trunk card is supported on IP500 Digital Station, IP500 Analog Phone and IP500 VCM base cards. They are not supported on the IP500 Legacy Card Carrier base card.

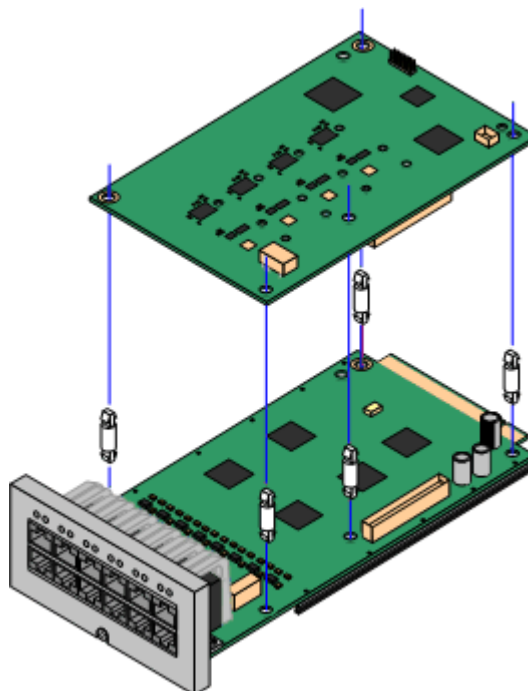

For those base cards that support daughter cards, there are no restrictions on the combination of card types. However in systems with both Analog Phone 8 base cards and analog trunk daughter cards, combining the two types are recommended as it then provides analog power failure support for one trunk/extension (Not applicable to the Analog Phone 2 base card).

Each daughter card is supplied with the spacer pegs required for installation and a label to identify the card's presence on the physical unit once installed.

- IP500 Analog Trunk Card (Maximum 4).
- IP500 BRI Trunk Card (Maximum 4).
- IP500 Universal PRI Trunk Card (Maximum 4).

IP500 Analog Trunk Card

This card can be added to an IP500 Digital Station card, IP500 Analog Phone base card, or IP500 VCM card. It allows that card to then also support 4 analog loop-start trunks. It also provides one analog V.32 modem.

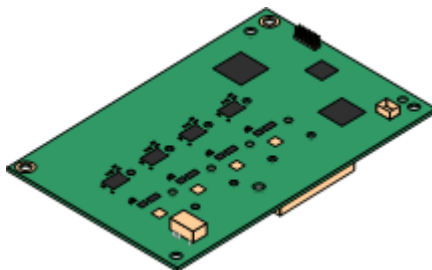

- When fitted to an IP500 Analog Phone 8 base card (not Phone 2), the combination supports 1 power failure extension to trunk connection.

IP500 BRI Trunk Card (Euro ISDN)

This type of card can be added to an IP500 Digital Station card, IP500 Analog Phone card, or IP500 VCM card. It allows that card to then also support up to 4 BRI trunk connections, each trunk providing 2B+D digital channels. The card is available in 2 port (4 channels) and 4 port (8 channels) variants.

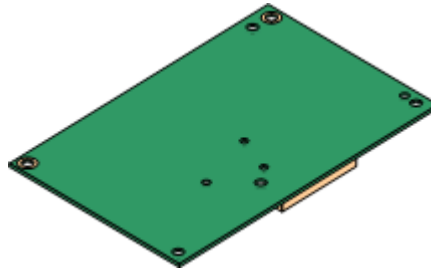

The ports on IP500 BRI cards can be individually configured to operate as an S-interface (S0 mode). When set as an S interface the settings for the Line will be exactly the same as for a circuit on an So8 Expansion Module.

- These trunks support the mobility features of [Mobile Call Control and one-X Mobile client](#)^[136].

IP500 Universal PRI Trunk Card

This type of card can be added to an IP500 Digital Station card, IP500 Analog Phone card, or IP500 VCM card. It allows that card to then also support primary rate digital trunk connections. Available in single and dual versions the IP400 PRI card provides single and dual primary rate trunk interfaces respectively. The PRI is configurable for T1, E1 or E1R2 MFC use depending on the territory.

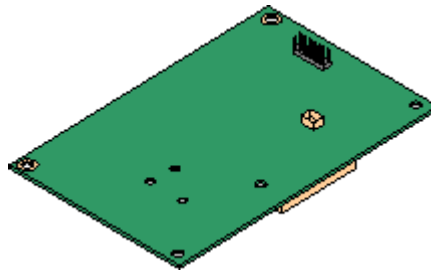

Details of the supported ISDN supplementary services and protocols for each PRI are given in the 'Public and Private Voice Networks' section.

The IP500 Universal PRI trunk cards incorporate an integrated CSU/DSU. The CSU function allows the trunk to be put in loop-back mode for testing purposes. This can be set manually, using the monitor application, or automatically from a Central Office sending a Line Loop Back (LLB) pattern. The DSU function allows the T1 trunk to be shared between data and voice services.

Here is a summary of the capabilities of the card:

- Each card is configurable to connect to T1, E1 or E1R2 lines.
- The card is available in either a single or dual PRI variant. The single variant can support up to 24 T1 channels or up to 30 E1 channels. The dual variant can support up to 48 T1 channels or 60 E1 channels.
- On each card, 8 channels per interface are enabled by default. This means that the single PRI has 8 channels enabled, while the dual PRI has 16 channels enabled. Further channels may be enabled by the purchase of additional licenses in 2-channel or 8-channel increments.
- The IP500 PRI daughter card works on any IP500 VCM or extension base card (not the Legacy Card Carrier).
- Up to four Universal PRI cards can be installed in any combination in the IP500 or IP500 V2 chassis.
- Diagnostics capabilities:
 - Visual indicators to show service state
 - Physical test points to monitor traffic.
- These trunks support the mobility features of [Mobile Call Control and one-X Mobile client](#)^[136].

External Expansion Modules

Unless otherwise stated, each of these modules may be used with the IP500, IP406 V2 and IP412.

- [IP500 Phone Expansion Module](#) ^[56]
Available in two variants for 16 or 30 analog extensions with calling line presentation.
- [IP500 Digital Station Expansion Module](#) ^[55]
Available in two variants for 16 or 30 digital extensions for Avaya series digital telephones.
- [IP500 Analog Trunk 16 Expansion Module](#) ^[54] *(US version only)*
Provides 16 analog loop start or ground start trunks, with power failover of two trunks.

IP500 Analog Trunk 16 Module

This expansion module provides an additional sixteen Loop Start or Ground Start two-wire analog trunks. (Ground start trunks are not available in all territories) The first two trunks on the module which are automatically switched to power fail sockets on the rear of the unit in the event of power being interrupted must be loop start for correct power fail operation.

For installations in a rack, this module requires the IP500 Rack Mounting Kit. The IP500 Analog Trunk 16 Module is functionally identical to the IP400 Analog Trunk 16 Module.

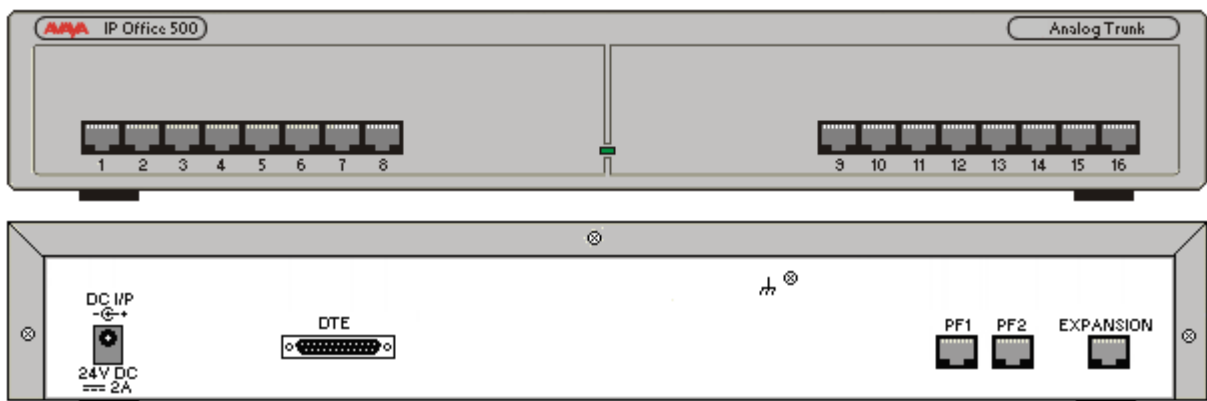

IP500 Digital Station Module

This expansion module provides additional Digital Station (DS) ports for selected Avaya 1400, 2400, 4400, 5400, 6400, T3 (EMEA only) Series phones and 3810 wireless phones (North America only). The IP500 Digital Station module is available in 2 variants; 16 or 30 extensions.

For installations in a rack, this module requires the IP500 Rack Mounting Kit. The IP500 Digital Station Module is functionally identical to the IP400 Digital Station V2 Module.

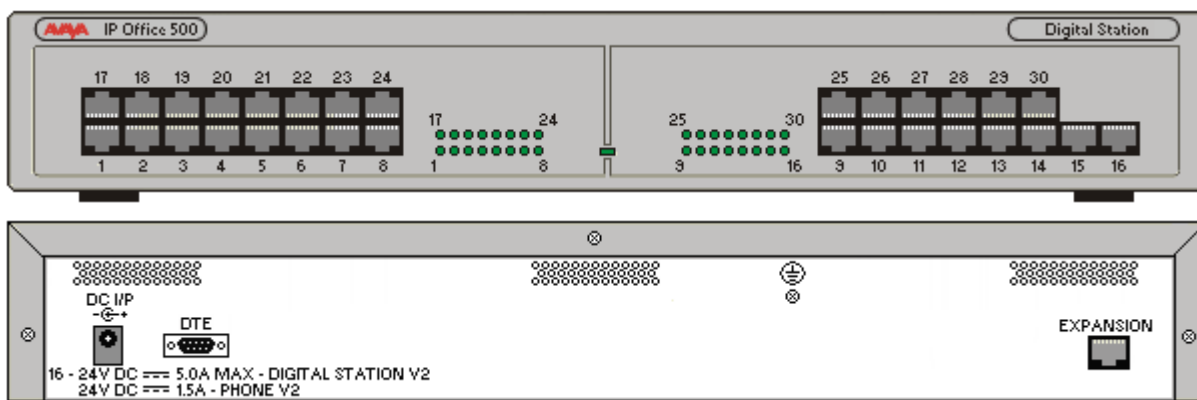

- Telephones can be located up to 3280 feet (1km) from the control unit. For extensions located "out-of-the-building" additional line protection will be needed. For more information on cabling and out of building guidelines, see the IP Office Installation Manual.
- For systems where Direct Station Select (DSS) Units are being used, IP Office supports a maximum of:
 - BM32: (1616)
Up to 32 DBM32s supported (32 buttons each, up to 1024 buttons).
 - DSS4450: (4412D+, 4424D+)
Up to 8 DSS4450 modules per system (maximum of 2 per DS expansion module, including the IP406v2) (50 buttons each, max 400 buttons).
 - DBM32: (1416)
Up to 32 DBM32s supported (32 buttons each, up to 1024 buttons).
 - EU24/EU24BL: (4620, 4621, 5420, 5620, 5621/4620, 4621, 5620, 5621)
Up to 8 EU24s per system (24 buttons each, max 196 buttons).
 - SBM24: (9630G, 9640, 9640G, 9650, 9650C)
Up to 42 SBM24s per system (24 buttons each, up to 1008 buttons).
 - T3 Series: (All T3 phones)
Up to 30 T3 DSS modules supported. (36 buttons each, up to 1080 buttons). T3 DSS buttons are not included in the overall system limit for additional button module buttons.
 - XM24: (6416+, 6424+)
Up to 10 XM24 units per system (maximum of 2 per DS expansion module, including the IP406v2) with a maximum of 1 per 6416+/6424+ phone (24 buttons each giving a maximum of 240 XM24 buttons).

See the [Telephones Section](#) ⁵⁸ for specific limits on the number of each type of telephone supported on DS modules.

IP500 Phone Expansion Module

This module provides additional analog telephone interfaces:

- Two Wire.
- DTMF signaling (No rotary or Loop Disconnect).
- Time Break Recall (No Earth Recall).
- Caller ID capable.
- Message Waiting Indication (MWI) capable - High Voltage, Pulsed High Voltage, Line Reversal.

The IP500 Phone module is available in 2 versions, giving 16 or 30 extensions. Telephones can be located up to 3280 feet (1km) from the control unit. For extensions located "out-of-the-building" additional line protection will be needed. For more information on cabling and out of building guidelines, see the IP Office Installation Manual.

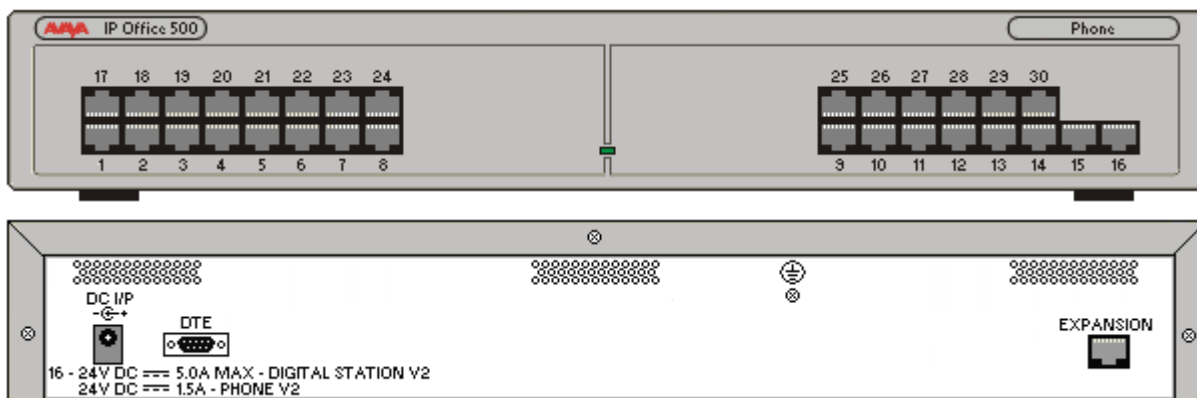

- IP Office Phone Modules provide support for a variety of analog MWI methods. These methods are 51V Stepped, 81V, 101V and Line Reversal.
- Each analog port can support a device of maximum 1 REN.
- On analog ports, call information is sent while the phone is ringing, and cannot be updated during a call or set on an outbound call (the phone may do a local match but this is not controlled by the IP Office). The primary purpose of displays is to give information about incoming calls. Where the Caller Display standard chosen supports the delivery of text (extension name) as well as the number, both are delivered.
- An analog extension port can be set for external Paging operation. It does not operate like a normal extension and is connected to external equipment through an isolation device. The Port will always be busy so it cannot be called directly and can only be accessed by using a paging feature. When not receiving a Page, the port will remain silent. When being paged, the page tone is sent before the speech path is opened.

Chapter 4. Telephones

4. Telephones

The right phone for the User:

With a wide choice of telephones, supporting both digital and IP interfaces, Avaya IP Office has always the right phone for a user.

Key-driven phones for the cost-sensitive customer

The 1600 IP phone and 1400 digital phones are classical, cost effective Telephones designed especially around the needs of the Small and Mid-Size Business customer. Keys with clear red and green LEDs make access to lines and feature a breeze. These phones are especially well suited for cost sensitive customers as well in scenarios where "key-system-functionality" is needed. They provide an easy migration pass for users that have been accustomed to e.g. the 4400 line or the PARTNER line of digital telephones.

Paperless phones for fast installation and cost efficient changes:

The new 9600 IP phones, as well as the 5600 IP and 5400 Digital telephones are especially welcomed where a low cost of ownership is important. All phones are equipped with paperless keys, making it easy to change features and button assignments from remote. The shift/page button allows access to a large number of lines or features that are shown dynamically in the display, making access to IP Office functionality easy while providing a clean, easy to use user-interface.

Access to phones everywhere in and IP Office Network (SCN):

With support of hotdesking across a large line of telephones, IP Office phones are perfect in an environment where people change their workplace regularly. With a simple login, users can make any telephone, digital or IP, their personal extension. This works not only in a single IP Office but also across a "small community network", making traveling from one company site to another a breeze.

Even better, on 9600, 1600 and 1400 telephones, this functionality has been further enhanced by providing a centralized call log, directory and personal settings. When hotdesking to a different phone, call-logs and directory are instantly updated and synchronized over the network, eliminating e.g. lost calls as the call log was not available at a remote site.

Avaya IP Office Desktop phones are designed to meet typical user needs in the small and mid business market:

- **Walk Up**
Phones in common areas like a meetings room, lobby or store. The phones are normally used by casual users that walk-up to a phone where they make a quick phone call. Normally, no sophisticated features are needed.
 - Example user: Customer, Visitor.
- **Everyday**
Users that need a phone on their desk as part of their everyday job. While having a phone is important, the phone is just another tool on the desk for users using several alternative communication technologies.
 - Example user: Engineer, Accountant.
- **Receptionist/Assistant**
A typical user manages a lot of calls, often as a significant part of their job. In many cases they also manage calls for others users and need to be efficient in connecting callers to the right people.
 - Example user: Executive Assistant, Receptionist.
- **Executive**
For these users, handling a lot of calls is essential and they are constantly on the phone. Quite often, they handle multiple calls; they must always be connected, even when mobile. They require a set of rich, yet easy to use communication capabilities.
 - Example user: Sales Executive, Banker, Lawyer, Project leader.

Phones for the different Usage categories:

- **Walk Up:** 1603, 1403, 5402/2402, T3 Compact (Europe only)
- **Everyday:** 1603SW (Basic Everyday), 1608, 9620/9620C, 1408, 5610SW/4610SW, 5410/2410, T3 Classic (Europe only)
- **Receptionist/Assistant:** 1616 (with BM32 if needed), 9650 with SBM24, 1416 (with DBM32 if needed), 5621/4621SW with EU24, 5420/2420 with EU24, T3 Comfort (Europe only)
- **Executive:** 9630, 9640, 5621/4621SW, 5420/2420, T3 Comfort (Europe only)

9600 Series IP Telephones

Avaya one-X Deskphone is a family of next generation IP telephones that delivers a new and unique communications experience to drive increased productivity.

The Avaya one-X Deskphone family features an intuitive user interface which helps to make users proficient and confident in performing common telephone tasks such as setting up a conference call or completing a transfer. With high quality audio it is much easier to hear and understand other people, which speeds business while reducing fatigue and stress. The Avaya 9600 Series Deskphones are built with future growth and enhancement in mind, with many modular add-ons that can be added as they are needed – protecting investments and leading to improved total cost of ownership. The new telephones also feature a very stylish and professional design including support for customized display screen saver images and custom faceplates with company logos.

- The 9620L/9620 C: a member of the Avaya one-X Deskphone Edition family, is specifically designed for the everyday telephone user—those who rely on multiple communications tools such as e-mail and IM, yet still require a high quality and intuitive telephone for voice communications. The 9620L IP Telephone features a high resolution 3.45 inch (9 cm) diagonal monochrome backlit display – while the 9620C features a color display for even better readability. The 9620L/C support up to 12 call appearances / administered feature keys - with three concurrent line appearances visible at any time.
- The Avaya 9650/9650C: The Avaya 9650 IP Telephone, a member of the Avaya one-X Deskphone Edition family, is specifically designed for the "navigator" telephone user. Navigators, such as building receptionists and executive admin staff, frequently manage calls for themselves and for groups of people. The 9650 features built-in button module functionality with one-touch access to bridged appearances, speed dials and feature keys. The Avaya 9650 IP Telephone delivers advanced communications capabilities, high definition audio, an integrated WML application interface, and comprehensive one-touch access. This is the ideal solution for receptionists, executive assistants, contact center agents as well as knowledge workers who need quick access to features and call appearances. The 9650 IP Telephone features a 3.8 inch (9.65 cm) diagonal ¼ VGA quality gray-scale pixel-based display with adjustable angle, while the 9650C enhances usability with a color display for even better readability. The 9650 supports up to 24 call appearances / administered feature keys.
- The Avaya 9630G/9640/9640G: a member of the Avaya one-X Deskphone Edition family, the 9640 IP Telephone with high resolution color display is specifically designed for the executive telephone user. The 9630G IP Telephone features a native Gigabit switch and a 3.8 inch (9.65 cm) diagonal monochrome backlit display - which has been enhanced with higher resolution (1/4 VGA) compared to other available monochrome telephones from Avaya. The 9640 IP Telephone features a 3.8 inch (9.65 cm) diagonal high resolution color backlit display. The 9640G model has the same functionality as the 9640, and adds native support for Gigabit. The 9630/9640 supports up to 24 call appearances/administered feature keys with six concurrent line appearances visible at any time.

Common to all phones of the 9600 line on IP Office are two access modes to important IP Office features: Features can be assigned to the line/feature key of the telephone for easy and quick one-touch selection of the functionality giving users of other Avaya telephones a consistent user-interface.

In addition the features can be accessed through a menu, allowing quick access to seldom used features or even functionality that is not administered to a key. Similar to menus found on mobile and smartphones, this intuitive, "self-service" access frees the user from limits imposed by the number of keys on a telephone and allows access to the vast functionality of IP Office.

The status indication presents a clear view of important call settings like call forwarding numbers.

Visual Voice gives menu access to the voicemail messages received by a user for quick retrieval of the most critical information.

Personal and centralized directory access makes calling a breeze. A centralized call log allows one-touch call-back of missed calls, and is fully synchronized with other Avaya IP phones or the one-X Portal application.

Full user mobility between different 9600 phones, 1600 phones and 1400 digital phones support hotdesking and user mobility between different phones with access to all the features found on the 'home' phone.

Customers are becoming more aware of the need to conserve energy due to costs and environmental considerations. The 9600 series phones have best in class power performance with the 9620L meeting PoE Class 1, and all other models being Class 2, including the Gigabit versions. Over the life of a product the reduced power demand of the 9600 series results in significant cost savings for customers when compared to other competitive offerings that require more power, such as PoE Class 3 devices.

Please note that the 9600 phones are supported on IP Office IP500 and IP500 V2 hardware only!

9620L, 9620C IP Telephones

Avaya 9620 IP Telephones are specifically designed for the everyday telephone user – those who typically rely on multiple communications tools such as e-mail and instant messaging (IM), yet still require a high quality and intuitive telephone for voice communications.

The Avaya one-X Deskphone family features an intuitive user interface which helps to make users proficient and confident in performing common telephone tasks such as setting up a conference call or completing a transfer.

With access to up to 12 lines and features through a simple-to-navigate interface, plus a clear view of 3 lines/features with LED indicators, the phones are efficient to use while the small footprint consumes minimal space on a users desktop.



Works on:	IP Office	Communication Manager
9620L	✓	✓
9620C	✓	✓

Common Features:

- Display/Housing:
 - 7-line 3.45 inch backlight graphical display with 320*160 pixels. 9620L: grayscale; 9620C: color
 - Flip stand/dual position
- Fixed Buttons: 10 plus Four-way navigation cluster button.
 - Volume up/down (separate volume levels for the handset, speaker, and ringer), Mute button (LED), Speaker button(LED), Headset button(LED).
 - Avaya Menu button (browser, options and settings access), Telephony application button – to return to main telephone screen.
 - Contacts button, Call log button (LED), quick-access voicemail Message button with LED and corner message indicator.
- Programmable/Contextual buttons:
 - 4 contextual softkey buttons. Context sensitive allocation of e.g. Hold, Transfer, Conference and more.

- 12 virtual Appearance/Feature buttons, accessible through navigation cluster. Three features shown at a time with three LED indicators.
- Key Labels: Icons and text used on fixed feature keys.
- Features Menu: Mobile cell phone style menu with access to most often used features like Call Forwarding, Park, Settings etc. On screen status indication for activated features like call forwarding.
- Speakerphone: Full duplex speakerphone
- Hearing Aid Compatible: Yes - ergonomic hearing aid compatible handset also supporting TTY acoustic coupler.
- Message Waiting Indicator: Yes - also useable as a ringing call alert indicator.
- Personalized Ring Patterns: Yes - 8.
- Headset Socket: Yes.
- Embedded Applications:
 - Centralized call log and contact application, fully transparent between 9600 phones, 1408/1416/1608/1616 phones and one-X Portal for IP Office.
 - Contacts application (up to 100 entries) and Call Log (Missed, Incoming, Outgoing, up to 30 calls). Please note that the Voice-dial feature of the 9600 phones on Communication Manager is not available on IP Office.
 - Access to company directory and Visual Voice applications on IP Office.
- External Applications: WML Application Interface
- Upgradeable Firmware: Yes.
- Expansion:
 - Adapter interface: 9620L none, 9620C, one expansion module interface for e.g. Gigabit Ethernet adapter.
 - USB adapter: 9620L none, 9620C: yes
- Color: Black.
- Mounting: Desk or wall mountable with optional wall mount adapter.
- Supports the following languages: English, French, Spanish, German, Italian, Dutch, Portuguese and Russian (English and 4 of the other languages at once in the phone).
Note: While it may be possible to download other languages onto the phone, this will not be applicable to any data sent by IP Office. If you switch the language to any other not listed above, the display will show a mixture of the new language and the user's default language on IP Office.

Requirements for IP Interface:

- Power Supply: IEEE 802.3af Power over Ethernet (PoE) or optional wall plug local power supply. 9620L: PoE Class 1, 9620C PoE Class 2
- Codecs/audio: G.711, G.729a/b, G.726, Dynamic Jitter buffer, Echo Cancellation, Comfort Noise, Automatic Gain Control.
Ready for future support of G.722 wideband codec.
- QoS Options: UDP Port Selection, DiffServ and 802.1p/q (VLAN).
- SNMP Support: Yes.
- IP Address Assignment: Static or dynamic IP address assignment.
- Ethernet Ports: Ethernet (10/100) line interface with a secondary 10/100 port for co-located laptop or PC with VLAN separation.
- Support of optional Gigabit Ethernet Adapter: 9620L: external. 9620C integrated adapter using adapter interface.

9630, 9640, 9640G Telephone

Smart, sleek, stylish and highly functional, the Avaya 9640 IP Telephone is designed for the Essential user, those for whom the telephone is essential in order to perform their jobs. Workers who conduct much of their business on the phone — moving from one call to the next. The Avaya 9630/9640 delivers advanced communications capabilities — high definition audio, a brilliant high resolution pixel based color display on the 9640, an integrated WML application interface, one-touch access to Avaya IP Office mobility or forwarding features — in a solution designed for those who are absolutely dependent on voice communications for their business operations.

With built in Gigabit Ethernet on the 9630G and 9640G, these phones are also perfectly suited for customers with very high requirements for data network performance.



Works on:	IP Office	Communication Manager
9630G	✓	✓
9640	✓	✓
9640G	✓	✓

Common Features:

- Display/Housing:
 - 9-line 3.8 inch backlight graphical display with 320*240 pixels. 9650: grayscale; 9650C: color
 - Flip stand/dual position
- Fixed Buttons: 11 plus Four-way navigation cluster button.
 - Volume up/down (separate volume levels for the handset, speaker, and ringer), Mute button (LED), Speaker button(LED), Headset button(LED).
 - Avaya Menu button (browser, options and settings access), Telephony application button – to return to main telephone screen. Call Forward shortcut button
 - Contacts button, Call log button (LED), quick-access voicemail Message button with LED and corner message indicator.
- Programmable/Contextual buttons: 10.
 - 4 contextual softkey buttons. Context sensitive allocation of e.g. Hold, Transfer, Conference and more.
 - 6 self-labeled Appearance/Feature buttons with LED for access to 24 administered Appearances/Features at the side of the display.
- Key Labels: Icons and text used on fixed feature keys.

- Features Menu: Mobile cell phone style menu with access to most often used features like Call Forwarding, Park, Settings etc. On screen status indication for activated features like call forwarding.
- Speakerphone: Full duplex speakerphone
- Hearing Aid Compatible: Yes - ergonomic hearing aid compatible handset also supporting TTY acoustic coupler.
- Message Waiting Indicator: Yes - also useable as a ringing call alert indicator.
- Personalized Ring Patterns: Yes - 8.
- Headset Socket: Yes.
- Embedded Applications:
 - Centralized call log and contact application, fully transparent between 9600 phones, 1408/1416/1608/1616 phones and one-X Portal for IP Office.
 - Contacts application (up to 100 entries) and Call Log (Missed, Incoming, Outgoing, up to 30 calls). Please note that the Voice-dial feature of the 9600 phones on Communication is not available on IP Office.
 - Access to company directory and Visual Voice applications on IP Office.
- External Applications: WML Application Interface
- Upgradeable Firmware: Yes.
- Expansion:
 - 2 Adapter interface:
 - USB 1.1 adapter
 - SBM24 Module interface for up to 3 x SBM 32-button expansion modules (Note: If more than one button module is used, Power Class of phone needs to be switched to Power Class 3)
- Color: Black.
- Mounting: Desk or wall mountable with optional wall mount adapter.
- Supports the following languages: English, French, Spanish, German, Italian, Dutch, Portuguese and Russian (English and 4 of the other languages at once in the phone).
Note: While it may be possible to download other languages onto the phone, this will not be applicable to any data sent by IP Office. If you switch the language to any not listed above, the display will show a mixed of the new language and the user's default language on IP Office.

Requirements for IP interface :

- Power Supply: IEEE 802.3af Power over Ethernet (PoE) or optional local power supply: Power Class 2 for all models including GiG-E versions.
- Codecs/audio: G.711, G.729a/b, G.726, Dynamic Jitter buffer, Echo Cancellation, Comfort Noise, Automatic Gain Control. Ready for future support of G.722 wideband codec.
- QoS Options: UDP Port Selection, DiffServ and 802.1p/q (VLAN).
- SNMP Support: Yes.
- IP Address Assignment: Static or dynamic IP address assignment.
- Ethernet Ports:
 - 9640: Ethernet (10/100) line interface with a secondary 10/100 port for co-located laptop or PC with VLAN separation.
 - 9630G/9640G: Gigabit Ethernet (10/100/1000) line interface with a secondary 10/100/1000 port for co-located laptop or PC with VLAN separation.
 - Support of optional integrated Gigabit Ethernet adapter using adapter interface.

9650, 9650C IP Telephones

Smart, sleek, stylish and highly functional, the Avaya 9650 IP Telephone is designed for the Essential and Navigator user profiles who need one touch access to features and bridged appearances of team/Partner buttons. Building receptionists, executive admin staff are examples of Navigator users who answer incoming calls, transfer customers to other extensions and monitor several bridged appearances throughout the day. This is the ideal solution for receptionists, executive assistants, Contact Center Agents as well as Knowledge workers that need quick access to partner and team features.



Works on:	IP Office	Communication Manager
9650	✓	✓
9650C	✓	✓

Common Features:

- Display/Housing:
 - 9-line 3.8 inch backlight graphical display with 320*240 pixels. 9650: grayscale; 9650C: color
 - Flip stand/dual position
- Fixed Buttons: 10 plus Four-way navigation cluster button.
 - Volume up/down (separate volume levels for the handset, speaker, and ringer), Mute button (LED), Speaker button(LED), Headset button(LED).
 - Avaya Menu button (browser, options and settings access), Telephony application button – to return to main telephone screen.
 - Contacts button, Call log button (LED), quick-access voicemail Message button with LED and corner message indicator.
- Programmable/Contextual buttons: 15.
 - Four contextual softkey buttons. Context sensitive allocation of e.g. Hold, Transfer, Conference and more.
 - 3 self-labeled Appearance/Feature buttons with LED for access to 24 administered Appearances/Features at the side of the display.

- 8 Additional self-labeled Appearance/Feature buttons with LED with direct access to 2*8 Appearances/Features.
- Key Labels: Icons and text used on fixed feature keys.
- Features Menu: Mobile cell phone style menu with access to most often used features like Call Forwarding, Park, Settings etc. On screen status indication for activated features like call forwarding.
- Speakerphone: Full duplex speakerphone
- Hearing Aid Compatible: Yes - ergonomic hearing aid compatible handset also supporting TTY acoustic coupler.
- Message Waiting Indicator: Yes - also useable as a ringing call alert indicator.
- Personalized Ring Patterns: Yes - 8.
- Headset Socket: Yes.
- Embedded Applications:
 - Centralized call log and contact application, fully transparent between 9600 phones, 1408/1416/1608/1616 phones and one-X Portal for IP Office.
 - Contacts application (up to 100 entries) and Call Log (Missed, Incoming, Outgoing, up to 30 calls). Please note that the Voice-dial feature of the 9600 phones on Communication is not available on IP Office.
 - Access to company directory and Visual Voice applications on IP Office.
- External Applications: WML Application Interface
- Upgradeable Firmware: Yes.
- Expansion:
 - 2 Adapter interface:
 - USB 1.1 adapter
 - SBM24 Module interface for up to 3 x SBM 32-button expansion modules (Note: If more than one button module is used, Power Class of phone needs to be switched to Power Class 3)
- Color: Black.
- Mounting: Desk or wall mountable with optional wall mount adapter.
- Supports the following languages: English, French, Spanish, German, Italian, Dutch, Portuguese and Russian (English and 4 of the other languages at once in the phone).
Note: While it may be possible to download other languages onto the phone, this will not be applicable to any data sent by IP Office. If you switch the language to any not listed above, the display will show a mixture of the new language and the user's default language on IP Office.

Requirements for IP interface:

- Power Supply: IEEE 802.3af Power over Ethernet (PoE) or optional local power supply: Power Class 2
- Codecs/audio: G.711, G.729a/b, G.726, Dynamic Jitter buffer, Echo Cancellation, Comfort Noise, Automatic Gain Control. Ready for future support of G.722 wideband codec.
- QoS Options: UDP Port Selection, DiffServ and 802.1p/q (VLAN).
- SNMP Support: Yes.
- IP Address Assignment: Static or dynamic IP address assignment.
- Ethernet Ports: Ethernet (10/100) line interface with a secondary 10/100 port for co-located laptop or PC with VLAN separation.
 - Support of optional integrated Gigabit Ethernet adapter using adapter interface.

Accessories

SBM24 Adapter Module

The SBM24 Expansion Module is an optional device that extends the number of call appearances and Feature buttons available on the telephone. The SBM24 Expansion Module is supported on the 9630, 9640 & 9650 IP Phones and provides 24 additional programmable buttons - to be configured as call appearances, bridged appearances, or feature keys. A maximum of three SBM24 modules are supported on a single phone.



- 24 programmable call appearance/feature keys.
- Two backlight LCD screens for button labels. Buttons automatically labeled from the system (no paper labels).
- Connects directly to the associated phone.
- No separate power supply needed. However, using more than one button module changes the power class of the phone to Class 3.

The total number of SBM24 button modules supported on one IP Office system is 42, subject to the total system limits. Please refer to [System Button Module Support](#) ⁽⁸⁹⁾ for the total system limitations of button modules on IP Office.

A Button Module adapter (Ferrite adapter), is required when SBM24 button expansion module is used with the 9630G or 9640G IP telephones.

Bluetooth Adapter

The Bluetooth Adapter for 9600 Series IP Telephones allows Bluetooth communications devices such as headsets to interoperate with 9600 Series telephones. The adapter allows highly mobile workers to use the same Bluetooth headset with their 9600 Series Deskphone as they use with their cell phone.

The Avaya ABT-35H Bluetooth headset when used with the Bluetooth Adapter supports a wireless range of up to 30 feet from the Deskphone and provides simple call control (answer, hang-up) directly from the headset.

For users while at their desk, the Bluetooth Adapter allows the freedom of hands free communication along with investment protection for those already utilizing Bluetooth headsets while on the go. It supports the Avaya ABT-35 as well as many other third party Bluetooth Headsets

The Bluetooth Adapter can be used with all 9600 phones except the 9620L. It requires a separate "Wedge stand".

Gigabit Ethernet Adapter

The 9600 Gigabit Ethernet Adapter can be fully integrated into a wedge stand of the 9600 phones and provides a transparent upgrade option if customers decide to install Gigabit Ethernet at a later date. It is fully integrated into the management interface of the 9600 phones. It requires a separate "Wedge stand".

1600 Series IP Telephones 1400 Series Digital Telephones

Avaya one-X is a portfolio of communications solutions that deliver a powerful and consistent communications experience for the end user – across a variety of devices and interfaces. Avaya one-X solutions provide Intelligent Access to Intelligent Communications driving enhanced productivity and competitive advantage.

Avaya one-X Deskphone Value Edition, also called the 1600 Series of IP telephones, is a family of cost effective IP Telephones designed especially around the needs of the Small and Mid-Size Business customer.

For users of a digital solution, the 1400 Series of Digital telephones offer the same functionality and consistent communication experience on a line of digital telephones, giving customers the choice to select the right solution regardless of the method of connection.

With IP Office Release 6, the line of 1600 phones has been further enhanced with the 1600-I series, providing an easier-to-read graphical display with white backlight, consistent with the displays of the 1400 family.

Designed with the reliability you expect from Avaya, one-X Deskphone Value Edition telephones provide critical features and capabilities not often found in competitively priced models.

The family of 1400/1600 phones consist of three models, designed around different user needs:

- The 1403/1603 phone is designed for the Walk Up user and basic Everyday user. For a Walk Up scenario, the 1403/1603 is used common areas in offices, stockrooms, lobbies, or drop-in desks. Users can be building visitors, employees, or even customers who need a phone with a simple, familiar user interface. The 1603 phones comes in two versions: The 1603, a basic phone without Ethernet switch for locations where no PC is connected to the phone, typically for the walkup user, as well as the 1603 SW, with a basic Ethernet switch to connect additional components to the phone, well suited for the basic Everyday user.
- The Avaya 1408/1608 IP Telephone is designed for the Everyday user. Everyday users typically rely on several forms of communication including voice and email – and while they require a quality telephone, they rarely handle large amount of calls at the same time. Cubicle workers and sales staff are examples of Everyday users for whom the 1408/1608 delivers a productivity-enhancing telephone.
- The Avaya 1416/1616 IP Telephone is designed for the Receptionist/Assistant user. Receptionists, secretaries, and managers are examples of this type of user – people who answer incoming calls, transfer customers to different departments or extensions, and monitor several line appearances throughout a typical day. For the Receptionist/Assistant user, the 1416/1616 provides the most one-touch line/feature/speed-dial buttons without the need to scroll through on-screen lists.

All 1400/1600 phones share a consistent design line and feature a button-centric layout. With fast access to all needed features like hold, transfer and conference, easily readable back-lit displays and a stylish design, they are an important addition to the Avaya portfolio of phones for the Small and Mid-Size market.

All phones share a number of feature keys with clear, paper labels. On the 1408/1608 and 1416/1616, features are also available through a feature list on screen that makes selecting features and line appearances easy even when hotdesking to another phone.

The phones are accompanied by a complete set of accessories like cost efficient power supplies, easy to use paper labels and spare parts. For powering options for the 1600 IP phones refer to the section [Power Options for IP Telephones](#)^[160].

For easy and efficient generation of labels, free DESI printing software is available from <http://support.avaya.com> (on the 1600 Phone Series page). This can be used to print all labels correctly formatted on plain paper or available DESI labels. A PDF document with correct formatting can also be downloaded. Additionally, labels can be printed in the correct format directly from IP Office Manager.

For 1600 Series phones requiring Gigabit Ethernet support, a Gigabit Ethernet adapter is available - providing 10/100/1000 Mbps support for both the 1600 Series phone and co-located laptop or PC.

Note that no Ethernet cable is included with the 1600 Series phones. If a cable is needed, it should be ordered separately at the required length.

1603 and 1603SW IP Telephone 1403 Digital Telephone

This telephone is best suited for the Walkup and Basic Everyday user.



Works on:	IP Office	Communication Manager
1603	✓	✓
1603 SW	✓	✓
1603-I	✓ (R6)	✓
1603SW-I	✓ (R6)	✓
1403	✓	✗

The Avaya 1403/1603 supports 3 line appearances. Each of the buttons includes dual LEDs (red, green) providing explicit status for the user. For a familiar look and feel, the 1403/1603 includes several fixed feature keys for common telephone tasks including conference, transfer, drop, hold, and mute. In addition, the 1403/1603 includes a 2-way speakerphone. The display on the 1403/1603 measures two lines by 16 characters and is backlit for easier viewing in all lighting conditions.

The 1603 SW telephone has the same features/functionality as the 1603 phone, it adds on top of that however a secondary Ethernet port and is therefore targeted at the basic Everyday user.

The newly introduced 1603-I/1603SW-I are functionally equal to the 1603/1603SW but feature a higher quality graphical display with white backlight, identical to the display of the digital 1403 telephone.

Common Features:

- Display/Housing:
 - Backlit display – 2 rows by 16 characters. Green backlight for 1603/1603-SW, white backlight for 1603-I, 1603SW-I, 1403.
 - Reversible wedge stand for desktop and wall-mount use.
- Fixed Buttons: 10.
 - Volume up/down (separate volume levels for the handset, speaker, and ringer), Mute button, Speaker button.
 - Avaya Menu button (options and settings access).
 - Hold button, Conference button, Transfer button, Drop button, Redial button.
- Programmable/Contextual buttons: 3.
 - 3 line appearance key buttons – with dual LEDs (red, green) and paper labels (Printing tool available).

- Key Labels: Icons and text used on fixed feature keys.
- Speakerphone: Two-way handsfree speaker and microphone.
- Hearing Aid Compatible: Yes - ergonomic hearing aid compatible handset also supporting TTY acoustic coupler.
- Message Waiting Indicator: Yes - also useable as a ringing call alert indicator.
- Personalized Ring Patterns: Yes - 8.
- Headset Socket: No.
- Upgradeable Firmware: Yes.
- Expansion: None.
- Color: Black.
- Mounting: Desk or wall mountable.

Requirements for 1403:

- Connect to: Digital Station (DS) port.
- Power Supply: From phone system.

Requirements for IP interface: (1603, 1603SW, 1603-I, 1603SW-I)

- Power Supply: Optional IEEE 802.3af Power over Ethernet (PoE) adapter (class 2) or optional wall plug local power supply.
- Codecs/audio: G.711, G.729a/b, Dynamic Jitter buffer, Echo Cancellation, Comfort Noise, Automatic Gain Control.
- QoS Options: UDP Port Selection, DiffServ and 802.1p/q (VLAN).
- SNMP Support: Yes.
- IP Address Assignment: Static or dynamic IP address assignment.
- Ethernet Ports: 1603 - Single Ethernet (10/100) line interface. Support of optional Gigabit Ethernet Adapter.
- Ethernet Ports: 1603 SW Ethernet (10/100) line interface with a secondary 10/100 port for co-located laptop or PC with VLAN separation. Support of optional Gigabit Ethernet Adapter.
 - Well suited for everyday use, where typically smaller sized data files transferred (web, email file attachments) or less demanding data-transfer application/usage (thus less sensitive to data transfer completion times).
 - For highly demanding data traffic processing with large amounts of small packets we recommend the 1616 phone for full speed data throughput.

Language Support:

- 1403/1603: Supports the following languages: English, French, Spanish, German, Italian, Dutch, Portuguese and Russian (English and 4 of the other languages at once in the phone)

1608 IP Telephone 1408 Digital Telephone

This telephone is best suited for the Everyday user.



Works on:	IP Office	Communication Manager
1608	✓	✓
1608-I	✓ (R6)	✓
1408	✓	✓ (in future)

The Avaya 1408/1608 supports 8 line appearances / feature keys. Each of the buttons includes dual LEDs (red, green) providing explicit status for the user. For a familiar look and feel, the 1408/1608 includes several fixed feature keys for common telephone tasks including conference, transfer, drop, hold, and mute. In addition, the 1408/1608 includes a high quality two-way speakerphone, and supports a broad portfolio of Avaya wired and wireless headsets through its integrated headset jack.

The 1408/1608 features a context sensitive user interface along with three softkeys and a four-way navigation cluster – ideal for scrolling through the local contacts list or call logs. The display on the 1408/1608 measures three lines by 24 characters and is backlit for easier viewing in all lighting conditions.

The newly introduced 1608-I is functionally equal to the 1608 but features a higher quality graphical display with white backlight, identical to the display of the digital 1416 telephone.

Common Features:

- Display/Housing:
 - Backlit display – 3 rows by 24 characters. Green backlight for 1608, white backlight for 1608-I, 1408.
 - Dual position flip stand.
- Fixed Buttons: 15 plus Four-way navigation cluster button.
 - Volume up/down (separate volume levels for the handset, speaker, and ringer), Mute button, Speaker button, Headset button.
 - Avaya Menu button (options and settings access), Telephony application button – to return to main telephone screen.
 - Hold button, Conference button, Transfer button, Drop button.

- Contacts button, Call log button, Redial button, quick-access voicemail Message button.
- Programmable/Contextual buttons: 11.
 - 8 line appearance/feature key buttons – with dual LEDs (red, green) and paper labels (Printing tool available). Note: For typical installs, the first 3 buttons are reserved for standard call appearances; a minimum of 2 call appearance buttons is needed for standard operation.
 - Three contextual softkey buttons.
- Key Labels: Icons and text used on fixed feature keys.
- Features Menu: Mobile cell phone style menu with access to most often used features like Call Forwarding, Park, Settings, etc. On screen status indication for activated features like call forwarding.
- Speakerphone: High quality two-way handsfree speaker and microphone.
- Hearing Aid Compatible: Yes - ergonomic hearing aid compatible handset also supporting TTY acoustic coupler.
- Message Waiting Indicator: Yes - also useable as a ringing call alert indicator.
- Personalized Ring Patterns: Yes - 8.
- Headset Socket: Yes.
- Embedded Applications:
 - Centralized call log and contact application, fully transparent between 108/1608/1416/1616 phone, 9600 phones and one-X Portal for IP Office.
 - Contacts application (up to 100 entries) and Call Log (Missed, Incoming, Outgoing, up to 30 calls).
 - Access to company directory and Visual Voice applications on IP Office.
- Upgradeable Firmware: Yes.
- Expansion: None.
- Color: Black.
- Mounting: Desk or wall mountable with optional wall mount adapter.

Requirements for 1408:

- Connect to: Digital Station (DS) port.
- Power Supply: From phone system.

Requirements for IP interface (1608, 1608-I):

- Power Supply: IEEE 802.3af Power over Ethernet (PoE) class 2 device or optional wall plug local power supply.
- Codecs/audio: G.711, G.729a/b, Dynamic Jitter buffer, Echo Cancellation, Comfort Noise, Automatic Gain Control.
- QoS Options: UDP Port Selection, DiffServ and 802.1p/q (VLAN).
- SNMP Support: Yes.
- IP Address Assignment: Static or dynamic IP address assignment.
- Ethernet Ports: Ethernet (10/100) line interface with a secondary 10/100 port for co-located laptop or PC with VLAN separation.
 - Well suited for everyday use, where typically smaller sized data files transferred (web, email file attachments) or less demanding data-transfer application/usage (thus less sensitive to data transfer completion times).
 - For highly demanding data traffic processing with large amounts of small packets we recommend the 1616 phone for full speed data throughput.
 - Support of optional Gigabit Ethernet Adapter.

Language Support:

- 1408/1608: Supports the following languages: English, French, Spanish, German, Italian, Dutch, Portuguese and Russian (English and 4 of the other languages at once in the phone)

1616 IP Telephone 1416 Digital Telephone

This telephone is best suited for the Receptionist/Assistant User.



Works on:	IP Office	Communication Manager
1616	✓	✓
1616-I	✓ (R6)	✓
1416	✓	✓ (in future)

The Avaya 1416/1616 supports 16 line appearances/feature keys on the phone itself – and up to 3 x 32-button expansion modules, providing access to a total of 112 line/feature keys or speed dial buttons. This will satisfy the needs of even the most demanding secretary or receptionist. Each of the buttons features a dual LED (red, green) providing explicit status for the user. For a familiar look and feel, the 1416/1616 includes several fixed feature keys for common telephone tasks including conference, transfer, drop, hold, and mute. In addition, the 1416/1616 includes a high quality two-way speakerphone, and supports a broad portfolio of Avaya wired and wireless headsets through its integrated headset jack.

The 1416/1616 features a context sensitive user interface along with three softkeys and a four-way navigation cluster – ideal for scrolling through the local contacts list or call logs. The display on the 1416/1616 measures four lines by 24 characters and is adjustable for optimum viewing angle. Additional caller related information is displayed with active appearances for easier call handling. The display is backlit for easier viewing in all lighting conditions.

The newly introduced 1616-I is functionally equal to the 1616 but features a higher quality graphical display with white backlight, identical to the display of the digital 1416 telephone.

Common Features:

- Display/Housing:
 - Backlit display – 4 rows by 24 characters with adjustable display angle. Green backlight for 1616, white backlight for 1616-I, 1416.
 - Dual position flip stand.
- Fixed Buttons: 15 plus Four-way navigation cluster button.
 - Volume up/down (separate volume levels for the handset, speaker, and ringer), Mute button, Speaker button, Headset button.

- Avaya Menu button (options and settings access), Telephony application button – to return to main telephone screen.
- Hold button, Conference button, Transfer button, Drop button.
- Contacts button, Call log button, Redial button, Quick-access voicemail Message button.
- Programmable/Contextual buttons: 19.
 - 16 line appearance/feature key buttons – with dual LEDs (red, green) and paper labels (Printing tool available). Note: For typical installs, the first 3 buttons are reserved for standard call appearances; a minimum of 2 call appearance buttons is needed for standard operation.
 - Three contextual softkey buttons.
- Key Labels: Icons and text used on fixed feature keys.
- Feature Menu: Mobile cell phone style menu with access to most often used features like Call Forwarding, Park, Settings etc. On screen status indication for activated features like call forwarding.
- Speakerphone: High quality two-way handsfree speaker and microphone.
- Hearing Aid Compatible: Yes - ergonomic hearing aid compatible handset also supporting TTY acoustic coupler.
- Message Waiting Indicator: Yes - also useable as a ringing call alert indicator.
- Personalized Ring Patterns: Yes - 8.
- Headset Socket: Yes.
- Embedded Applications:
 - Centralized call log and contact application, fully transparent between 108/1608/1416/1616 phone, 9600 phones and one-X Portal for IP Office.
 - Contacts application (up to 100 entries) and Call Log (Missed, Incoming, Outgoing, up to 30 calls).
 - Access to company directory and Visual Voice applications on IP Office.
- Upgradeable Firmware: Yes.
- Expansion: Module interface.
 - 1616: For up to 3 * BM32 32-button expansion modules (Note: An external power supply is needed for all installs with more than 1 button module).
 - 1416: for up to 3 * DBM32 32-button expansion modules (Note: An external power supply is needed in any case): Note: While the 1416 supports three DBM32, availability of the DBM32 will be slightly delayed compared to availability of 1416.
- Color: Black.
- Mounting: Desk or wall mountable with optional wall mount adapter.

Requirements for 1416:

- Connect to: Digital Station (DS) port.
- Power Supply: From phone system.

Requirements for IP interface (1616 and 1616-I):

- Power Supply: IEEE 802.3af Power over Ethernet (PoE) class 2 device or optional wall plug local power supply.
- Codecs/audio: G.711, G.729a/b, Dynamic Jitter buffer, Echo Cancellation, Comfort Noise, Automatic Gain Control.
- QoS Options: UDP Port Selection, DiffServ and 802.1p/q (VLAN).
- SNMP Support: Yes.
- IP Address Assignment: Static or dynamic IP address assignment.
- Ethernet Ports: Ethernet (10/100) line interface with a secondary 10/100 port for co-located laptop or PC with VLAN separation. Support of optional Gigabit Ethernet Adapter.

Language Support:

- 1416/1616: Supports the following languages: English, French, Spanish, German, Italian, Dutch, Portuguese and Russian (English and 4 of the other languages at once in the phone).

BM32 Button Module for 1616 IP Phones DBM32 Button Module for 1416 Digital Phones



The DBM32/BM32 Button Module extends the number of feature buttons on your Avaya 1416 Digital/1616 IP Telephone. It provides 32 additional buttons all with dual LEDs (red, green) for easy visibility.

Up to 3 DBM32/BM32 button modules can be connected to a 1416/1616 phone. The total number of DBM32/BM32 button modules supported on one IP Office system is 32, subject to the total system limits. Please refer to [System Button Module Support](#) for the total system limitations of button modules on IP Office.

Note that the DBM32 can only be used with the Digital 1416 while the BM32 is for use with the 1616 IP phone.

Typical uses are:

- to provide additional lines for calls bridged from one or more other extensions
- to provide abbreviated dialing buttons
- to provide buttons to access additional switch features like call forwarding

Please note that an external power supply is always needed for a DBM32 connected to a 1416 telephone and is needed when connecting more than one BM32 to a 1616 telephone.

The DBM32 module is planned to become available during the first half of 2010.

5402, 5602 SW, 2402, 4602 SW Telephone

These telephones are best suited for the Walkup User.



Telephone	Works on IP Office	Works on IP Office and Communication Manager
5402	✓	✗
5602 SW	✓	✗
2402	✓*	✓
4602 SW	✓	✓

*Early 2402 telephones can make and receive call but the display will not function.

Note: The 5602 SW and 4602 SW phones are supported by IP Office Release 6 but are no longer available for new sales.

Common Features:

- Display: 2 lines x 24 characters.
- Fixed Feature Buttons: 10 - Conference, Transfer, Drop, Redial, Speaker, Messages, Hold, Mute, Volume Up, Volume Down.
- Programmable Feature Buttons:
 - DS Phones: 2 plus an additional 12 programmable feature keys can be accessed via the FEATURE key.
 - IP Phones: 2.
- Key Labels: Icons and text used on fixed feature keys. Display labels and icons used on 2 programmable feature keys.
- Speakerphone: Listen-only handsfree speaker (no microphone).
- Hearing Aid Compatible: Yes.
- Message Waiting Indicator: Yes. On the 2402 and 5402 this is can also be used as a ringing call alert indicator.
- Personalized Ring Patterns: Yes- 8 (via Conference button when idle).
- Headset Socket: No, this telephone does not support headset operation.
- Embedded Applications: None.
- Upgradeable Firmware: DS Phones - No. IP Phones - Yes.
- Expansion: None.
- Color: Multi-gray.
- Mounting: Desk or wall mountable.
- Adjustable Desk Stand: No.

Requirements for 5402 and 2402:

- Connect to: Digital Station (DS) port.
- Power Supply: From phone system.

Requirements for 5602 SW and 4602 SW:

- Power Supply: IEEE 802.3af Power over Ethernet (PoE) or individual power supply unit (Avaya 1151 series).
- Codecs: G.711, G.729a/b.
- QoS Options: UDP Port Selection, DiffServ and 802.1p/q (VLAN)
- SNMP Support: Yes.
- IP Address Assignment: Static or dynamic IP address assignment.
- Ethernet Ports: Two port full-duplex 10/100 BaseT Ethernet switch for PC pass-through connection.
 - Auto-negotiation provided separately for each port.
 - 802.3 Flow Control.
 - Phone has priority over PC port at all times.

5410, 5610 SW, 2410, 4610 SW Telephones

These telephones are best suited for the Receptionist/Assistant User.



Telephone	Works on IP Office	Works on IP Office and Communication Manager
5410	✓	✗
5610 SW	✓	✗
2410	✓	✓
4610 SW	✓	✓

Note that 4610, while supported on IP Office R6, is not longer available for new sales

Common Features:

- Display: 5 lines x 29 characters (168 x 80 pixel 4-grayscale).
- Fixed Feature Buttons: 10 - Conference, Headset, Transfer, Drop, Redial, Speaker, Hold, Mute, Volume Up, Volume Down.
- Programmable Feature Buttons:
 - DS Phones: 12 - in 2 switchable display pages of 6 matching the 6 physical display buttons.
 - IP Phones: 24 - in 4 switchable display pages of 6 matching the 6 physical display buttons.
- Key Labels: Icons and text used on fixed feature keys.
- Speakerphone: Two-way handsfree speaker and microphone.
- Hearing Aid Compatible: Yes.
- Message Waiting Indicator: Yes - can also be used as a ringing call alert indicator.
- Personalized Ring Patterns: Yes - 8.
- Headset Socket: Yes.
- Embedded Applications: Speed Dial List (48) and Call Log (Missed, Incoming, Outgoing). Also WAP WML browser supported on IP phone models.
- Upgradeable Firmware: Yes.
- Expansion: None.
- Color: Multi-gray.
- Mounting: Desk or wall mountable.
- Adjustable Desk Stand: Yes - Supplied with phone.

Special Features for the 5410 and 2410:

- Messages Button: Dedicated button to collect voicemail.

Requirements for 5410 and 2410:

- Connect to: Digital Station (DS) port.
- Power Supply: From phone system.

Requirements for 5610 and 4610:

- Power Supply: IEEE 802.3af Power over Ethernet (PoE) or individual power supply unit (Avaya 1151 series).
- Codecs: G.711, G.729a/b.
- QoS Options: UDP Port Selection, DiffServ and 802.1p/q (VLAN)
- SNMP Support: Yes.
- IP Address Assignment: Static or dynamic IP address assignment.
- Ethernet Ports: Two port full-duplex 10/100 BaseT Ethernet switch for PC pass-through connection.
 - Auto-negotiation provided separately for each port.
 - 802.3 Flow Control.
 - Phone has priority over PC port at all times.

5420, 5621, 2420, 4621, 4625 Telephones

These telephones are best suited for the Executive User and with the optional EU24 Button Module good for the Receptionist/Assistant User.



Telephone	Works on IP Office	Works on IP Office and Communication Manager
5420	✓	✗
5621 SW	✓	✗
2420	✓	✓
4621 SW	✓	✓
4625 SW	✓	✓

Note that 4621 and 4625, while supported on IP Office R6 are not longer available for new sales.

Common Features:

- Display: 7 lines x 29 characters.
- Fixed Feature Buttons: 10 - Conference, Headset, Transfer, Drop, Redial, Speaker, Hold, Mute, Volume Up, Volume Down.
- Programmable Feature Buttons:
 - DS Phones: 24 - arranged in 3 switchable display pages of 8 matching the 8 physical display buttons.
 - IP Phones: 24 - arranged in 2 switchable display pages of 12 matching the 12 physical display buttons.
- Key Labels: Icons and text used on fixed feature keys.
- Speakerphone: Two-way handsfree speaker and microphone.
- Hearing Aid Compatible: Yes.
- Message Waiting Indicator: Yes - can also be used as a ringing call alert indicator.
- Personalized Ring Patterns: Yes - 8.
- Headset Socket: Yes.
- Embedded Applications: Speed Dial List (104) and Call Log (Missed, Incoming, Outgoing). Also WAP WML browser supported on IP phone models.
- Upgradeable Firmware: Yes.
- Expansion: Supports the EU24 DSS expansion module (with additional Avaya 1151 power supply).
- Color: Multi-gray.
- Mounting: Desk or wall mountable.
- Adjustable Desk Stand: Yes - Supplied with phone.

Special Features for the 5420 and 2420:

- Messages Button: Dedicated button to collect voicemail.

Requirements for 5420 and 2420:

- Connect to: Digital Station (DS) port.
- Power Supply: From phone system.

Requirements for 5621 SW, 4621 SW, 4625 SW:

- Power Supply: IEEE 802.3af Power over Ethernet (PoE) or individual power supply unit (Avaya 1151 series).
- Codecs: G.711, G.729a/b.
- QoS Options: UDP Port Selection, DiffServ and 802.1p/q (VLAN)
- SNMP Support: Yes.
- IP Address Assignment: Static or dynamic IP address assignment.
- Ethernet Ports: Two port full-duplex 10/100 BaseT Ethernet switch for PC pass-through connection.
 - Auto-negotiation provided separately for each port.
 - 802.3 Flow Control.
 - Phone has priority over PC port at all times.

Special Features for 5621 SW and 4621 SW:

- Display Backlight: The display has a backlight for improved contrast. Standby mode turns off backlight after time-out.

Special Features for 4625 SW:

- Color Backlight Display: The display is full color and has a backlight for improved contrast.

Note: While still supported, the 5620SW and 4620SW phones are no longer available for purchase.

EU24 and EU24 BL Expansion Modules



The EU24/EU24BL are phone expansion modules that work in association with a 5420, 5620/1, 2420, 4620/1, 4625 phones. They provide an additional 24 programmable buttons with associated display label and status icons. Only one EU24 can be used per phone. The EU24BL has a backlight and is for use with the 4621 and 5621 only.

The EU24/EU24BL supports an additional 24 Call Appearance/Feature buttons, by displaying a column of 12 buttons at a time, with a dotted line separating the two columns.

Common Features

- 24 Programmable call appearance/feature keys.
- Automatically labeled from the system (no paper labels).
- Connects directly to the associated phone.
- Requires an Avaya 1151 series power supply, even for IP phones already using Power over Ethernet (PoE).
- IP Office supports a maximum of eight EU24/EU24 BL's on each IP Office system, subject to total system limits. Please refer to [System Button Module Support](#)⁸⁹ for the total system limitations of button modules on IP Office.

Telephone	EU24	EU24BL
2402/5402	✗	✗
2410/5410	✗	✗
2420/5420	✓	✗
4601/5601	✗	✗
4602/5602	✗	✗
4610/5610	✗	✗
4620/5620	✓	✗
4621/5621	✓	✓
4625	✓	✓

Note that EU24 BL, while supported on IP Office R6, is not longer available for new sales.

T3 Telephones

The T3 range of digital Upn and IP telephones provide European style with context sensitive displays and are available in select European countries only.

T3 Compact

This telephone is best suited for the Walkup User. It is available in Europe only.



Common Features:

- Display: 1 line with 24 characters alphanumeric plus one line of icons
- Fixed Feature Buttons: 3 keys with printed text labels and 2 for Audio Volume control
- Programmable Feature Buttons: 3 keys with indicators and printed text labels, 2 keys with printed text labels
- Speakerphone: Full duplex handsfree speaker and microphone.
- Hearing Aid Compatible: Through optional headset
- Message Waiting and call log Indicator: Yes
- Personalized Ring Patterns: Yes, 8 ring patterns
- Embedded Applications: Navigation Cursor Control, Call signaling via LED and/or ringer; Alphanumeric entry via dialing keypad.
- Color: Graphite gray or polar white.
- Mounting: Desk or optional wall mountable.
- Adjustable Desk Stand: No

Features for T3 Upn only:

- Upgradeable Firmware: No.
- Optional Add-Ons: Up to 3 DSS Modules. T3 Headset link for wired headsets.
- Headset Socket: No. Optional headset add-on available.
- Connect to: Digital Station (DS) port.
- Power Supply: From phone system.

Features for T3 IP only:

- Upgradeable Firmware: Yes
- Headset Socket: Yes
- Optional Add-Ons: No
- Power Supply: IEEE 802.3af Power over Ethernet (PoE) or individual power supply unit.
- Codecs: G.711, G.729a/b.
- QoS Options: UDP Port Selection, DiffServ and 802.1p/q (VLAN)
- SNMP Support: No.
- IP Address Assignment: Static or dynamic IP address assignment.
- Ethernet Ports: Two port full-duplex 10/100 BaseT Ethernet switch.
 - Auto-negotiation provided separately for each port.
 - 802.3 Flow Control.

T3 Classic

This telephone is best suited for the Everyday User. It is available in Europe only.



Common Features:

- Display: 4 lines x 26 characters
- Fixed Feature Buttons: 5 preprogrammed keys with printed text labels and 2 for Audio Volume control
- Programmable Feature Buttons: 6 preprogrammed keys with indicators and printed text labels, 4 programmable keys with printed text labels
- Speakerphone: Two-way handsfree speaker and microphone.
- Hearing Aid Compatible: Through optional handset
- Message Waiting and call log Indicator: Yes
- Personalized Ring Patterns: Yes, 8 ring patterns.
- Headset Socket: No. Optional headset add-on available.
- Embedded Applications: Navigation Cursor Control, Call signaling via LED and/or ringer; Alpha entry via dialing keypad.
- Optional Add-Ons: Up to 3 DSS Modules. T3 Headset link for wired headsets.
- Color: Graphite gray or polar white.
- Mounting: Desk
- Adjustable Desk Stand: Display adjustable

Features for T3 Upn:

- Upgradeable Firmware: No.
- Optional Add-Ons: up to 3 DSS Modules
- Connect to: Digital Station (DS) port.
- Power Supply: From phone system.

Features for T3 IP:

- Upgradeable Firmware: Yes.
- Optional Add-Ons: up to 3 DSS Modules with AEI/Headsetlink,
- Power Supply: IEEE 802.3af Power over Ethernet (PoE) or individual power supply unit.
- Codecs: G.711, G.729a/b.
- QoS Options: UDP Port Selection, DiffServ and 802.1p/q (VLAN)
- SNMP Support: no.
- IP Address Assignment: Static or dynamic IP address assignment.
- Ethernet Ports: Two port full-duplex 10/100 BaseT Ethernet switch.
 - Auto-negotiation provided separately for each port.
 - 802.3 Flow Control.

T3 Comfort

This telephone is best suited for the Executive as well as the Receptionist/Assistant User. It is available in Europe only.



Common Features:

- Display: 17 lines x 40 characters, Integrated keyboard
- Fixed Feature Buttons: 5 preprogrammed keys with printed text labels and 2 for Audio Volume control
- Programmable Feature Buttons: 6 preprogrammed keys with indicators and printed text labels, 6 preprogrammed keys with printed text labels, 10 user programmable keys with associated display labels.
- Speakerphone: Two-way handsfree speaker and microphone.
- Hearing Aid Compatible: Through optional handset
- Message Waiting and call log Indicator: Yes
- Personalized Ring Patterns: Yes, 8 ring patterns.
- Headset Socket: No. Optional headset add-on available.
- Embedded Applications: Navigation Cursor Control, Call signaling via LED and/or ringer
- Optional Add-Ons: Up to 3 DSS Modules. T3 Headset link for wired headsets.
- Color: Graphite gray or polar white.
- Mounting: Desk
- Adjustable Desk Stand: Display adjustable

Features for T3 Upn:

- Upgradeable Firmware: No.
- Optional Add-Ons: up to 3 DSS Modules
- Connect to: Digital Station (DS) port.
- Power Supply: From phone system.

Features for T3 IP:

- Upgradeable Firmware: Yes.
- Optional Add-Ons: up to 3 DSS Modules with AEI/Headsetlink,
- Power Supply: IEEE 802.3af Power over Ethernet (PoE) or individual power supply unit.
- Codecs: G.711, G.729a/b.
- QoS Options: UDP Port Selection, DiffServ and 802.1p/q (VLAN)
- SNMP Support: No.
- IP Address Assignment: Static or dynamic IP address assignment.
- Ethernet Ports: Two port full-duplex 10/100 BaseT Ethernet switch.
 - Auto-negotiation provided separately for each port.
 - 802.3 Flow Control.

T3 DSS Expansion Modules

The T3 DSS Module is a phone expansion module that is compatible with all T3 Upn and T3 IP Telephones except the T3 IP Compact. Each module provides an additional 36 programmable buttons with associated printed text labels and indicators, and can be programmed for lines, groups or speed dial numbers. 3 DSS Modules can be added to each T3 phone. Power is provided by T3 Upn telephones, but an external power adapter is needed for each DSS module when used on T3 IP telephones.



T3 Comfort with T3 DSS Attached

IP Office 406, IP412 and IP500 support a maximum of 30 T3 DSS modules per control unit. Please refer to [System Button Module Support](#) ⁸⁹ for the total system limitations of button modules on IP Office.

System Button Module Support

IP Office supports a number of different button modules to provide phones with additional programmable buttons. The limits stated below are those applicable for the IP Office 4.2 2Q 2009 maintenance release and higher.

- BM32: *(1616)*
Up to 32 DBM32s supported (32 buttons each, up to 1024 buttons).
- DSS4450: *(4412D+, 4424D+)*
Up to 8 DSS4450 modules per system (maximum of 2 per DS expansion module, including the IP406v2) (50 buttons each, max 400 buttons).
- DBM32: *(1416)*
Up to 32 DBM32s supported (32 buttons each, up to 1024 buttons).
- EU24/EU24BL: *(4620, 4621, 5420, 5620, 5621/4620, 4621, 5620, 5621)*
Up to 8 EU24s per system (24 buttons each, max 196 buttons).
- SBM24: *(9630G, 9640, 9640G, 9650, 9650C)*
Up to 42 SBM24s per system (24 buttons each, up to 1008 buttons).
- T3 Series: *(All T3 phones)*
Up to 30 T3 DSS modules supported. (36 buttons each, up to 1080 buttons). T3 DSS buttons are not included in the overall system limit for additional button module buttons.
- XM24: *(6416+, 6424+)*
Up to 10 XM24 units per system (maximum of 2 per DS expansion module, including the IP406v2) with a maximum of 1 per 6416+/6424+ phone (24 buttons each giving a maximum of 240 XM24 buttons).

The maximum number of additional button module buttons per system is 1024 (regardless of if the buttons are configured for use or not). Only exception is use of T3 DSS only where, if no other button modules are used, a total of 1080 buttons is supported:

- 12 x BM32 + 5 x EU24 + 20 x SBM24 is allowed (984 buttons in total).
- 15 x T3DSS + 15 x BM32 is allowed (1020 buttons in total).
- but NOT 8 x BM32 + 10 x EU24 (because it exceeds the maximum number of 8 EU24s, even though total buttons < 1024).
- and NOT 14 x BM32 + 5 x EU24 + 20 x SBM24 (total 1048 buttons, this exceeds the maximum 1024 buttons per system).

Wireless and Remote Phone Solutions

Avaya IP Office Wireless Solutions include analog, digital and IP-based WiFi wireless phones. These are solutions employees can use every day to work more effectively and be more responsive to customers - all while increasing revenues and keeping communication costs firmly under control. Also, Avaya IP Office Mobility Solutions integrate seamlessly with IP Office, enhancing each customer's investment. IP Office's in-building Mobility Solutions improve communication with staff that, because of the function they perform, are mobile within the workplace. Using wireless technology, such individuals may be instantly contactable, with many obvious benefits:

- The wireless telephone is carried in the pocket, so users are not tied to the desk in order to remain in contact.
- Users may be contacted instantly to ensure fast, accurate decision making and immediate response to problems through planned radio coverage with no blind spots

Avaya Wireless and Remote Solutions

IP Office supports the following wireless solutions:

- DECT R4, is the mainstream IP based DECT solution, offered in the EMEA and NA regions and in selected APAC countries. With the new Compact base-station, it is also the first choice for small installs with smaller channel/capacity need.
- IP-DECT in the EMEA and NA regions and in selected APAC countries is also supported on IP Office. Note that the IP-DECT solution will be eventually completely replaced by DECT R4.
- Digital Wireless North American market.
- Avaya VoIP WiFi Solution offered worldwide in selected countries including North America, EU countries and selected others.

IP Office supports the following VPN remote phone solutions:

- VPN phone functionality on all supported 9600 phones. VPN functionality is an integral part of the 9600 software and does neither require a separate software load nor does it require a license.
- VPN phone client on 4610SW, 4621SW, 5610SW and 5621SW IP phones offered worldwide.

Which DECT solution should be used?

For all new installs, we strongly recommend selection of the new DECT R4 solution as future functionality additions will happen only on DECT R4. The new 3720 and 3725 handsets offer enhanced capabilities, the latter supporting a color screen and Bluetooth headset. The functionality GAP of DECT R4, requiring a AIWS server for corporate directory access, has been closed with Release 6, moving access to IP Office telephone book back onto the Master base-station.

While being fully supported on IP Office Release 5, the current IP-DECT solution with the 3701 and 3711 handsets will be replaced by the new DECT R4 solution with superior features in the upcoming future. End of Sale will be announced

Wireless - DECT R4

The Avaya DECT R4 solution delivers the productivity-boosting benefits of IP and wireless communications across multiple offices in a convenient, lightweight handset. It provides businesses with a highly functional wireless solution with the ability to scale to support large numbers of users. This system also supports users in different offices connected via a WAN. The Avaya DECT R4 solution radio fixed part or IP base station (IPBS) connects to the IP Office using an IP protocol based on H.323.

Avaya's DECT R4 solution features all advantages of a full blown DECT solution for the enterprise market: Cost effective high wireless voice quality in a frequency band exclusively reserved for DECT that is secure, easy to deploy and enhance.

New with R6:

- Access to the IP Office directory has been moved back to the master base-station, therefore an AIWS server is not required if only IP Office directory access is needed. Please note that AIWS is still needed for all other additional functionalities like handset to handset SMS and remote software upgrade.
- New four-channel Compact Base Station for small installs and low users counts

The solution consists of:

- Two wireless handsets.
- Two 8-channel radio base stations (with internal and external antennas) with IP interface for usage with IP Office.
- A cost efficient entry level base station "Compact" that support up to 4 channels. A system is limited to 5 of the RBS Compact at each time, expansion beyond 5 RBS is possible but requires the larger Base-stations.
- An appliance server for centralized functions like corporate directory and internal phonebook access, simple text messaging, integration of messaging and other external applications, centralized configuration and maintenance etc.

As the solution contains a handset with liquid protection and BlueTooth headset interface and an appliance server for attaching messaging applications it is especially well suited for verticals like healthcare and retail.

All handsets and radio base stations support the DECT frequency bands in EMEA, APAC, NAR and CALA with the same hardware and firmware. (Please check type approval for availability in the different regions)

The Avaya DECT R4 solution on IP Office supports up to 120 handsets and 32 base stations. Each base station can be powered over the LAN using the Power over Ethernet (PoE) standard. Each base station can be also powered by an external power supply. There are two versions of the base station (IPBS) available: , a standard base station with fixed antennas and an enhanced base station with a variety of external antennas (External antenna not available in the US). Both base-stations can be installed in an outdoor housing to provide an "external" base-station

Solution Overview

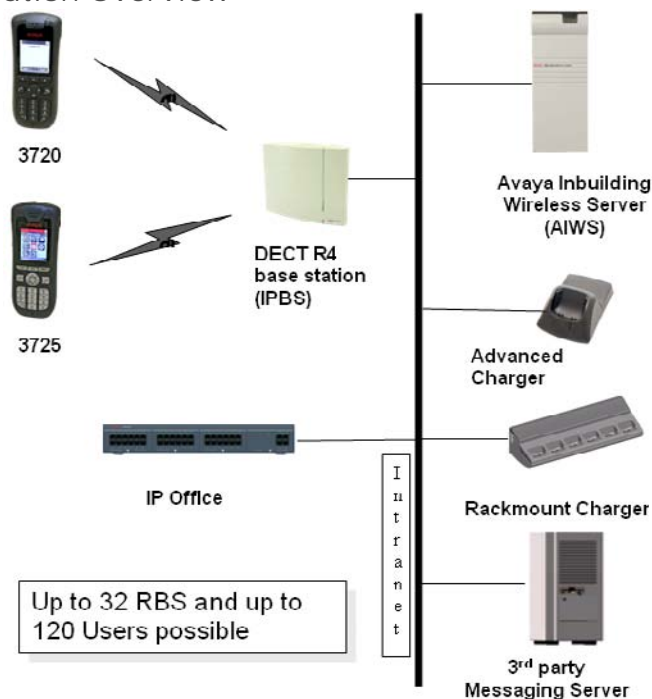

In all approved regions, this system supports the 3720 and 3725 handsets.

IP DECT Radio Base Station (RBS)

The DECT R4 Radio Base Stations are used with IP Office only. It connects directly to a LAN switch using Ethernet cabling. The DECT R4 Radio Base Stations can either be powered by Power-over-Ethernet or by using external power supplies that are available as accessories.

Each standard DECT R4 Radio Base Station can handle up to eight concurrent calls while each Compact Radio Base Station can handle up to 4 concurrent calls. A special protocol called on-air synchronization ensures that active calls are seamlessly handed over from one DECT R4 Radio Base Station to the next one if a user with an active call roams through a building.

To make sure that the on-air protocol works and that the whole building is covered by the ranges of the DECT R4 Radio Base Stations a site survey is needed to determine the number and placement of the DECT R4 Radio Base stations within the building. Avaya offers these site surveys as a service offer by AGS as well as measurement kits for business partners who want to do these site surveys on their own.

The on-air synchronization as well as the access to the phonebook of IP Office is done by a special software (master server) that can run in parallel to the standard DECT R4 Radio Base Station software on the same hardware.



DECT R4 Radio Base Station with internal antennas

DECT R4 Radio Base Station with external antennas

Each base station has the following features:

- Two variants of the standard Radio Base Station: With Internal antenna and with External Antenna due to regulation, in the US only the base-station with internal antenna may be used.
- There are several antennas available for the base-station with external antenna: Standard, Directional Single, Directional Dual, Omnidirectional.
- One variant of the Compact Radio Base Station with internal antennas. The compact base station has the same look and feel as the base station with internal antenna.
- Outdoor housing available for both versions
- 8 Simultaneous voice and up to 12 signaling channels for the standard Radio Base Stations.
- 4 Simultaneous voice and up to 12 signaling channels for the compact Radio Base Stations.
- Codec G.711, G723, G.729a/b for base station IP trunk connection.
- Power Consumption
- Power over Ethernet or local power supply supported
- Power over Ethernet, IEEE 802.3af, class 2, typical 4W, maximum 5W consumption.
- Dimension: 200 (w) x 165 (d) x 56 (h) mm including mounting bracket
- Weight RBS: 450g.

DECT Feature Overview

Given the degree of integration available to wireless users with DECT, there are a variety of means by which calls can be routed to wireless handsets:

- **Handover**
While in motion, the handset performs continuous measurements to determine which DECT R4 base station has the strongest signal. The one that can be best received is defined as the active Base station. To prevent the handset from rapidly switching back and forth between two base stations that are equally well received, threshold values are used. Handover between base stations occurs seamlessly whether a call is active or not.
- **DECT Networking**
An DECT R4 telephone can travel from one office to another which is connected over a wide area network (WAN) link and make and take calls. In this scenario the main DECT R4 controller remains at one "headquarters" location, with slave base stations in up to 31 other offices.
- **DDI /DID**
Since each wireless handset is an extension on the IP Office system calls may be routed directly using a DDI/DID number.
- **Transfer**
Calls may be transferred to DECT extensions by operators or other extension users and DECT extension users may transfer callers to any other extension user.
- **Hunt group compatibility**
Wireless handsets may be programmed as members of groups and answer calls in the same manner as any other extension within that group.
- **Group working**
Wireless handsets may be programmed as members of groups and attract calls in the same manner as any other extension within that group. DECT handsets must NOT be configured into collective groups.
- **Divert destination**
Users may initiate any or all divers from an Avaya desk phone to a wireless handset.
- **Twinning**
Twinning allows calls to a user main extension number to alert at both that extension and a secondary extension. Though not restricted to DECT, this feature is aimed primarily at users who have both a desk phone and a wireless extension. Calls from the secondary twinned extension are presented as if from the users main extension. Presentation of call waiting and busy is based on whether either of the twinned extensions is in use.
- **DECT R4 Capacities:**

Feature	DECT R4
Maximum Handsets	120
Maximum Base Stations if Master Server is on a standard RBS	32
Maximum Base Stations if Master Server is on a Compact RBS	5
Total Base Stations/Compact Base Stations	32
Total number of Compact Base Stations	5
Maximum simultaneous calls	100*

*May be limited by the available VCM voice compression channels for calls to non-IP destinations. DECT R4 on IP Office does not support Redundancy option.

- **Licensing and Redundancy**
Other than IP-DECT, DECT R4 does not require any licensing by itself (next to the licensing for the appropriate VCM channels in IP Office). DECT R4 on IP Office does not support Redundancy option

DECT R4 Inbuilding Wireless Server (AIWS)

The Avaya Inbuilding Wireless Server enhances the functionality of the DECT R4 with additional functionality such as IP Office and LDAP directory access, centralized management and software update as well as handset to handset SMS plus basic web messaging.

Avaya In-Building Wireless Server (AIWS) is a server for handling wireless services and messaging. It runs on a solid state embedded Server (AIWS Hardware). It comes pre-installed, with the appropriate features activated on that server.

For installation and maintenance, this server is managed by a PC using Windows Internet Explore (6.0 or above) and Sun's Java Runtime Environment.

Several variants of the server are available. All Servers come fully installed and preloaded with licenses so no extra installation is needed. There is no upgrade available from e.g. Basic to standard.

	Basic	Basic+	Standard	OAP
NTP Server <i>(IP Office can also act as NTP Server)</i>	X	X	X	X
Access To Central Phonebook	X	X	X	X
Access To Corporate Directories <i>(LDAP on CM /TFTP on IPO)</i> <i>(from release 6, central IP Office phonebook is also supported directly on the Master RBS)</i>	X (only IPO)	X (only IPO)	X (IPO & LDAP)	
SMS Handset to Handset	X	X	X	X
Basic Web Messaging	X	X	X	X
Netpage Web Messaging			X	
Software Download Over-The-Air		X (up to 32 handsets)	X (up to 120 handsets)	
Software Download Via Advanced/Rack Charger		X (up to 32 handsets)	X (up to 120 handsets)	
Centralized Handset Configuration Over-The-Air		X (up to 32 handsets)	X (up to 120 handsets)	
Centralized Handset Configuration Via Advanced/Rack Charger		X (up to 32 handsets)	X (up to 120 handsets)	
Virtual SIM Card		X (up to 32 handsets)	X (up to 120 handsets)	
AIWS as Protocol Converter				X (only OAP)

DECT R4 Accessories

In addition to the standard chargers, a number of high functionality chargers exist:



- Basic Charger
 - Charges one DECT phone (3720 and 3725)
 - Charge time: 4 hours.



- Advanced Charger
 - Charges one DECT phone (3720 and 3725)
 - Supports easy replacement of telephones
 - Connected to configuration tool PDM (Portable Device Manager) via USB or Ethernet
 - Charge time: 4 hours.



- Rackmount Charger
 - Same functionality as the advanced charger but for up to 6 DECT phones (3720 and 3725)
 - Charge time: 4 hours.



- Multiple Battery Charger
 - Charges 6 batteries (3725).

- Portable Device Manager
Software to be used in combination with Advanced or Rackmount Charger in order to Manage the 3720 and 3725 phone:
 - Requirements: Windows XP® Professional, Service Pack 2 (SP2) or Windows Vista® Business operating system, Sun Java Runtime Environment (JRE) 6 or later, Acrobat Reader 5 or higher.

- Other accessories
 - Handset Basic Belt Clip
 - Handset Swivel Belt Clip
 - Handset Leather Case (3720 and 3725)
 - Handset Security Chain

Wireless - Avaya IP DECT

Note: While still supported on IP Office release 6 and available for upgrades, we strongly suggest to use DECT R4 for new installs.

The IP DECT solution delivers the productivity-boosting benefits of IP and wireless communications across multiple offices in a convenient, lightweight handset. It provides businesses with a highly functional wireless solution with the ability to scale to support large numbers of users. This system also supports users in different offices connected via a WAN. The Avaya IP DECT solution radio fixed part (RFP) or base station connects to the IP Office using an IP protocol based on H.323.

The Avaya IP DECT solution supports up to 120 handsets and 32 base stations. Each base station can be powered over the LAN using the Power over Ethernet (PoE) standard. Each indoor base station can also optionally be connected to main power via an external power adaptor. Each outdoor base station can only be powered using PoE - no individual power supplies are available to power the outdoor IP DECT base station.

In EMEA and APAC this system supports the 3701 and 3711 handsets.

In North America, only the 3711 handset is supported.

Note: The regulatory requirements for the radio part (base station and Handset) are slightly different in the US and Canada compared to EMEA and APAC. Therefore, while providing the same functionality, the hardware is different in these two regions.

Each Base station has the following features:

- 8 simultaneous Voice and up to 12 Signaling Channels.
- Codec G.711, G.723, G.729 for base station IP trunk connection.
- Handover

While in motion, the handset performs continuous measurements to determine which IP DECT base station has the strongest signal. The one that can be best received is defined as the active Base station. To prevent the handset from rapidly switching back and forth between two base stations that are equally well received, threshold values are used. Handover between base stations occurs seamlessly whether a call is active or not.

- DECT Networking

An IP DECT telephone can travel from one office to another which is connected over a wide area network (WAN) link and make and take calls. In this scenario the main IP DECT controller remains at one "headquarters" location.

Given the degree of integration available to wireless users with DECT, there are a variety of means by which calls can be routed to wireless handsets:

- DDI /DID
Since each wireless handset is an extension on the IP Office system calls may be routed directly using a DDI/DID number.
- Transfer
Calls may be transferred to DECT extensions by operators or other extension users and DECT extension users may transfer callers to any other extension user.
- Hunt group compatibility
Wireless handsets may be programmed as members of groups and answer calls in the same manner as any other extension within that group.
- Group working
Wireless handsets may be programmed as members of groups and attract calls in the same manner as any other extension within that group. DECT handsets must NOT be configured into collective groups.
- Divert destination
Users may initiate any or all diverts from an Avaya desk phone to a wireless handset.
- Twinning
Twinning allows calls to a user main extension number to alert at both that extension and a secondary extension. Though not restricted to DECT, this feature is aimed primarily at users who have both a desk phone and a wireless extension. Calls from the secondary twinned extension are presented as if from the users main extension. Presentation of call waiting and busy is based on whether either of the twinned extensions is in use. In North America this functionality became available in Release 4.0.7.

Avaya IP DECT System licensing

A license is necessary for this functionality. This license is called the Avaya IP Office IP DECT Mobility Manager license. This license is entered through the main base station (ADMM) and is NOT entered through the IP Office System manager. A feature key server is NOT necessary to enable the IP DECT functionality. No separate PC or software is required with this system.

In all regions, a "plug and play" licensing mechanism is available: It consists of a pre-licensed and ready to go two-base-station bundle ("IP DECT IPO STARTER KIT ") and two pre-licensed base stations ("IP DECT RFP32/34 UPG KIT") that can be added to the system independent of the number of licenses in ADMM. This allows easier deployment and upgrades of systems without the need to buy a separate upgrade-license. For IP Office we recommend to use the "Starter Kits" and the "Upgrade Kits" for new installations for added flexibility and to minimize the installation effort.

The bundles that have previously been available in EMEA will continue to be available and are compatible with the pre-licensed base stations described above, if the latest software is installed on the IP-DECT system, e.g. upgrade an existing 5-base-station system with an "Upgrade-Kit" when adding an extra base-station instead of upgrading the system-license to a 6+ license.

Additional upgrade licenses will continue to be available for systems that need to expand their current coverage or capacity.

IP DECT Capacities

Feature	IP DECT
Maximum handsets	120
Maximum base-stations	32
Total base-stations/repeaters	32
Maximum simultaneous calls	100*

*May be limited by the available VCM voice compression channels for calls to non-IP destinations.

Wireless - WiFi (802.11)

The Avaya IP Wireless solution offers an advanced Voice over IP (VoIP) client for wireless networks. This solution allows SME's to take advantage of the cost savings and simplified management of a converged voice and data infrastructure.

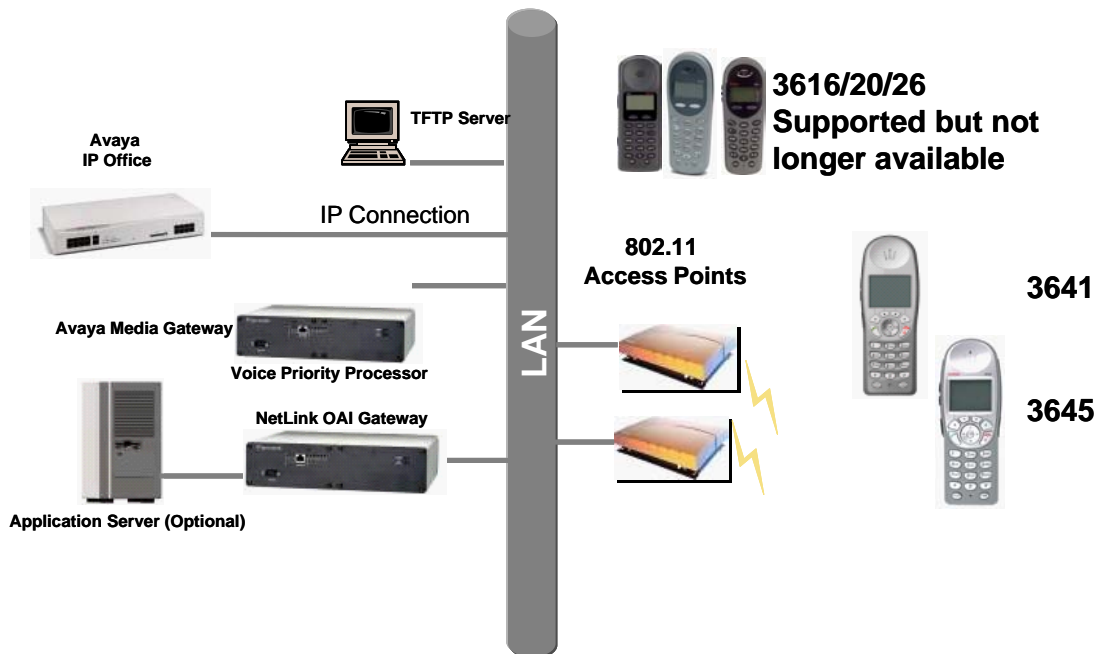

The 3641 and 3645 phones provide an improved user-interface, a new lightweight design and a radio that supports several WiFi standards (802.11a/b/g). With these handsets customers have an increased choice to fit their needs and infrastructure.

Based on global standards for wireless LAN's, the Avaya IP Wireless Telephone Solution simplifies network infrastructure by enabling voice traffic to be carried along with data traffic over the same wireless network. 3616, 3620 and 3626 telephones are supported but no longer available from Avaya for direct sequence 802.11b WiFi networks; the 3641 and 3645 will also work in 802.11a and 802.11g networks. These phones are also field upgradeable through external TFTP clients (not included), so telephones can be updated with new protocols, features, and capabilities as they become available.

Users can have a choice of an executive or rugged workplace telephone and all the productivity benefits of their desk telephone in this next generation of wireless telephone solutions.

Wireless IP Terminals

Users can have a choice of 2 WiFi phones to meet their in building mobility needs:

- Both support the 802.11 a/b/g standards and up to 12 lines or selected features. Both of these handsets are resistant to dust and spraying water and therefore also suitable for harsh environments. They also offer office-quality speaker-phone functionality.
- Avaya 3641 supports a broad range of enterprise applications and is ideally suited for general office, financial or hospitality industries. This compact handset offers a high-resolution backlight graphic display a new, improved user-interface and design and a lightweight form factor.
- Avaya 3645 is a slightly larger version that in addition supports "push-to-talk" functionality for broadcast communication between employees. Due to its rubberized sized grips and the larger ear cup it is especially well suited in noisy and industrial environments.
- Access to 2*6 lines or selected features through the "line" key and the "FCN" key (no individual labels are supported for the administered functions on the function keys, status information only for call appearances but not for line appearances).

Avaya Voice Priority Processors

The Avaya Voice Priority Processor (AVPP) is an Ethernet LAN appliance that works with access points to provide Quality of Service (QoS) on the wireless LAN. All packets to and from the wireless phones pass through the AVPP and are encapsulated for prioritization as they are routed to and from IP Office. AVPP is fully compliant with the IEEE 802.11a/b/g standards.

AVPP is required for QoS because the current IEEE 802.11a/b/g wireless LAN standards provide only limited mechanism for differentiating audio packets from data packets. It also delivers quality of service by limiting the number of phones that are connected to one access point in order to avoid quality problems. In addition AVPP ensures that the phone can run in energy-efficient mode when not in use. The following AVPPs are available to meet customer needs:

- AVPP100: Serves 80 calls simultaneously.
- AVPP020: Serves 20 powered-on handsets.
- AVPP010: Serves 10 powered-on handsets.

Wireless Access Points

When using the Avaya Wireless IP solution, customers can utilize wireless access points from various vendors. The list of compatible wireless access points is large and constantly growing. Please visit http://www.polycom.com/support/voice/wi-fi/view_certified.html and select "WLAN Compatibility List" for the latest information.

Benefits

- Supports 802.11 a/b/g standards for Wi-Fi networks converging voice and data over a single network.
- Seamless integration with IP Office.
- Excellent voice quality on converged wireless networks.
- Lightweight, durable handsets specifically designed for workplace use.
- Improved display, battery life, processor power all with lower costs.
- Increased range of AVPP's to address the needs of diverse construct sizes.
- Multitude of accessories are available:
 - Dual Charger (full charge accomplished in approximately one and a half hours).
 - Quick Charger (full charge accomplished in approximately one and a half hours).
 - Single, Dual, and Quad Chargers for the 3641 and 3645 phones.
 - Belt Clip.
 - Nylon Pouch.
 - Carrying case with Lanyard.
 - Hands Free Pouch.
 - Noise canceling headset.
 - Over the ear headset.

Avaya IP Wireless Telephony Solution (AWTS) Open Application Interface (OAI) Gateway

The AWTS Open Application Interface (OAI) Gateway enables third- party software applications to communicate with the Avaya IP Wireless Telephones. This serves as a two-way messaging device. Many companies provide applications that interface to your in-house paging systems, email, and client-server messaging. Other vendors with complementary systems such as nurse call, telemetry, alarm, and control system manufacturers are currently developing applications to interface with the Avaya IP Wireless Telephone solution.

3616 Wireless Telephone

While no longer available, this WiFi telephone is still supported on IP Office Release 6.

The Avaya 3616 IP Wireless Telephone is a WiFi (802.11b) telephone that runs using H.323.



The 3616 supports the following features:

- Lightweight innovative design .
- Simple to use.
- 802.11b standard-compatible.
- Radio Frequency 2.4000 – 2.835 GHz (SMI).
- Transmission type Direct Sequence Spread Spectrum (DSSS).
- FCC certification Part 15.247.
- Management of telephones via DHCP and TFTP.
- Voice encoding G711.
- Transmit Power 100mw peak, <10mW average.
- Wired Equivalent Privacy (WEP), 40bit and 128 bit.
- 2x16 character alphanumeric, plus status indicators.
- 4 hours talk time and 80 hours standby.

3626 Ruggedized Wireless Telephone

While no longer available, this WiFi telephone is still supported on IP Office Release 6.

The Avaya 3626 Wireless Telephone is a WiFi standard (802.11b) telephone that runs using H.323.



The [3626](#) supports all of the features of 3616 with the following differences:

- Designed for industrial environments.
- Ruggedized durable design.
- Push-to-talk (walkie-talkie) feature for broadcast communications between employees.

Note: 3626 supports both R1.0 and R2.0 firmware on the set itself. However, as of R3.1 of IP Office, only 3626 phone R1.0 firmware is supported.

3641 Ruggedized Wireless Telephone

The Avaya 3641 Wireless Telephone is a WiFi standard (802.11a/b/g) telephone that runs using H.323.



The 3641 supports the following features:

- Slim lightweight design with large display.
- Backlight display with Icons.
- Simple to use with improved user interface.
- Navigation and soft keys for simple access to frequently used operations.
- Office-quality speakerphone for handsfree operation.
- 802.11a/b/g standard-compatible.
- Radio Frequency 2.4000 GHz (b/g) or 5.8 GHz (a).
- FCC certification Part 15.247.
- Management of telephones via DHCP and TFTP.
- Voice encoding G711, G.729a.
- Wired Equivalent Privacy (WEP), 40bit and 128 bit and 802.11i (PSK) for secure communication.
- Lithium Ion Battery pack with up to 8 hours talk time and 160 hours standby.
- IP-53 Design (Liquid/dust protection).
- MIL 810F Design (Shock protection).
- Clips, cases, lanyard.

3645 Ruggedized Wireless Telephone

The Avaya 3645 Wireless Telephone is a WiFi standard (802.11a/b/g) telephone that runs using H.323.



The 3645 supports all of the features of [3641](#)^[103] with the following additions:

- Push-to-talk (PTT) functionality for workgroup communication
- Enlarged earpiece for operation in noisy environments
- Rubberized grips for improved ergonomics and durability

3720 DECT

This telephone is fully supported on the Avaya DECT R4 system.

However, it can also be used on an Avaya IP DECT system in "GAP-mode" with functionality limited to standard calling functionality, DECT roaming and handover. Access to IP Office central directory as well as time of day update is not available in GAP-mode.



Standard DECT handset:

- Black and white display with Backlight and Icons
- Loudspeaker / hands free
- Graphical user interface
- Four way navigation key
- 6 built-in UI languages
- Standby 180 hours , Talk Time 16 hours (under optimal conditions)

3725 DECT

This telephone is fully supported on the Avaya DECT R4 system

However, it can also be used on an Avaya IP DECT system in 'GAP-mode' with functionality limited to standard calling functionality, DECT roaming and handover. Access to IP Office central directory as well as time of day update is not available in GAP-mode.



Standard DECT handset:

- Color Display with Backlight and Icons
- Loudspeaker / hands free
- Build in Bluetooth 2.0, supporting the "headset" profile. While others standard compliant headsets should work, Avaya has only tested and therefore guarantees functionality of the following headsets only:
 - SonyEricsson HBH-PV702
 - SonyEricsson HBH-GV435
 - SonyEricsson HBH-IV835
 - Plantronics Voyager510
 - Plantronics Explorer665
 - Nokia BH-201
 - Jabra BT8010
 - Motorola H350
 - Motorola H670
 - Samsung WEP410
- Graphical user interface
- Four way navigation key
- 19 built-in UI languages. However, in some languages menu items may appear in the English language.
- Standby 180h, Talk Time 16h (under optimal conditions) Bluetooth headset interface (Bluetooth 2.0, handsfree profile)
- Liquid and dust protected (IP 44)
- Multi-functional button (alarm call, answer call, etc.)
- Text message support (requires AIWS, 30 messages sent/received storable, message length 160 characters)

Avaya 3720 and 3725 DECT Handsets Feature Overview

	Telephone	3720 DECT Telephone	3725 DECT Telephone
Keys:	Keypad	yes	yes
	Hook on/off buttons	yes	yes
	Softkeys	3	3
	Navigation cluster	4-way	5-way
	Volume buttons		yes
	Mute button		yes
	Alarm button		yes
Display:	Display, illuminated	112 x 115 pixels, Black and white	128 x 160 pixels, 64K colors
	Battery indicator	yes	
	Signal strength indicator	yes	
	Time and date display	yes	
Audio:	Handsfree	yes, 2-way speakerphone	
	Headset interface 2.5 mm	yes	
	Bluetooth 2.0 Headset profile	no	yes
	Supported Ring tones	14	14
	Ring tone volume	8 levels	
	Vibration	yes	
	Ringling options	Ring, Vibration, visual	
	Usage profiles	supported	
	Keyes beep	yes, selectable	
	Volume control	8 levels	8 levels
Features	Message LED (Red-green)	yes	yes
	Call log (Local)	25 entries	25 entries
	Local Directory/Contacts	250	250
	Access to IP Office Directory	Possible ^[1]	Possible ^[1]
	Support of Text Messaging	no	Optional ^[1]
	Phone lock	pin protected	pin protected
	Keyes lock	yes	yes
	Programmable "in Call Feature" menu	10 functions	10 functions
	Programmable "Call Services" Menu	10 functions	10 functions
	GAP compliant	yes	yes
Hardware:	Battery	Lithium Polymer	Lithium-Ion
	Standby/Talk time - No Bluetooth	160/16 hours	120/20 hours
	Standby/Talk time - with Bluetooth	n.a.	120/13 hours
	Charge time	4 hours	4 hours
	Dust/Liquid Protection level		IP 44
	Ruggedness	IEC 68-2-32, procedure 1, dropped 12 times from 1 metre	
	Size	133 x 53 x 24	134 x 53 x 26 mm

	Telephone	3720 DECT Telephone	3725 DECT Telephone
	Weight	115 g (battery and clip included)	130 g (battery and clip included)
	Belt clip options	none, standard, swivel	
Localization:	Supported languages	English,	Danish
		German	Dutch
		Spanish	English
		French	Finnish
		Russian ^[2]	French
		Downloadable language (one of 14 ^[2])	German
			Italian
			Norwegian
			Portuguese
			Spanish
			Swedish
			Polish ^[2]
			Greek ^[2]
			Czech ^[2]
Hungarian ^[2]			
Brasilian ^[2]			
Slovakian ^[2]			
Turkish ^[2]			
Russian ^[2]			

1. Requires AIWS Server for integration with IP Office

2. Language supported on phone, IP Office menu items might appear in English.

The new DECT R4 handsets will work with the legacy IP DECT system. Nevertheless not all features available with the 3701 and 3711 handsets will be available on the DECT R4 handsets as well. An (incomplete) list of working features is:

- Subscription with PARK.
- Basic Call.
- Display Messages (with some limitations, e.g. truncation at end of line).
- Handover.
- Roaming.
- R-Key Handling (Enquiry call, Conference, ...).
- Feature Access Codes.
- Distinguish between internal/external calls.
- DTMF during call.
- Local call log (calling party numbers are transmitted).
- Local time and date.

Features already known to be not working with DECT R4 handsets and the legacy IP DECT system are

- Access of external directory (e.g. LDAP).
- Get time and date from the system.

- WML (WAP access).
- SMS/Messaging (not a feature of the legacy IP DECT system).

Generally it is highly recommended to do a sample installation with one handset first before rolling out a larger set of DECT R4 handsets on a legacy IP DECT system

3701 IP DECT

This telephone is fully supported on the Avaya IP DECT system

However, it can also be used on the Avaya DECT R4 system in 'GAP-mode' with functionality limited to standard calling functionality, DECT roaming and handover. The built in feature list will not work on DECT R4.



- Listen-only handsfree speaker.
- SOS Emergency key for speed dialing an emergency number.
- Information key that can be used for:
 - Phone number lists and voice mail indication.
 - Information and speaker key flash when active.
- 50 phone book entries in every handset
- 10 possible ring tones with temporary mute.
- 4-level signal strength display.
- Speaker and handset volume, 3-levels and mute capability.
- Manual and automatic key lock (1 minute timer).
- Temporary ring tone muting.
- Silent charging.
- 12 menu languages: Czech, Danish, Dutch, English, Finnish, French, German, Italian, Norwegian, Portuguese, Spanish and Swedish. However, in the Czech and Norwegian language mode some menu items may appear in the English language.
- Illuminated 3-line graphic display (96 x 33 pixels), variable 3-level contrast.
- Stand-by time: Up to 100 hours.
- Talk time: Up to 10 hours.
- Charge time: max. 6 hours for empty batteries.
- Weight: 138 grammes including 3 AAA (NiMH) batteries.
- Dimensions (Height x Width X Depth): 146 x 55 x 28 mm.

Optional telephone accessories include:

- Desktop charger.
- An adapter cord for use with headsets.
- Heavy-duty belt clip.

3711 IP DECT

This telephone is fully supported on the Avaya IP DECT system

However, it can also be used on the Avaya DECT R4 system in 'GAP-mode' with functionality limited to standard calling functionality, DECT roaming and handover. The built in feature list will not work on DECT R4.



The 3711 phone supports the same features as the 3701 IP DECT handset but with the following differences:

- Full handsfree speakerphone operation.
- Headset connection (2.5 mm jack).
- Vibrating alarm.
- Personal phone book with 100 entries
- Access to system phone book.
- Voice Mail indication.
- Choice from 30 ring tones.
- Speaker and handset volume, 7-levels and mute capability.
- Automatic call pick-up using a headset.
- 10 menu languages: Danish, Dutch, English, Finnish, French, German, Italian, Portuguese, Spanish and Swedish.
- Illuminated 5-line graphic display, (96 x 60 pixels), variable 7-level contrast.

Optional handset accessories include:

- Desktop charger.
- An adapter cord for use with headsets.
- Heavy-duty belt clip.

Digital Wireless 3810 Telephone



Features

- 2-line, 32 character Handset Liquid Crystal Display (LCD).
- 10 hours of talk time, and 4 days of standby time.
- 4 displayed operation modes indicating Talk, Ringer On/Off, Battery Low, and Message Waiting.
- Single button access to fixed features – Hold, Transfer, Conference, and Redial.
- 4 programmable buttons to access features on the PBX.
- 20 Number Memory for quick and easy speed dialing
- 10 channels, supporting up to 10 simultaneous conversations in overlapping radio coverage areas.
- Headset jack.
- Ringer and Handset volume control.
- User selectable ring type.
- Vibrate alert.
- Redial Button
- Base Unit and Charger Unit.

The Avaya 3810 Wireless Telephone is a digital telephone designed to work with IP Office from release 2.0 and above by connecting to a Digital Station (DS) port. It offers the mobility inherent in a wireless telephone plus access to a number of features and functionality of the connected communications system.

A maximum of 5 Avaya 3810 wireless handsets can be connected to the same IP Office in any overlapping radio coverage area.

This phone is only available in the USA and Canada.

The Avaya 3810 is delivered as a single unit containing:

- Base Unit.
- Handset.
- Telephone Cord.
- Base Unit Power Supply Adapter.
- Charging Stand Power Supply Adapter.
- Rechargeable Battery.
- Belt Clip.
- Charging Stand.
- User and Installation Guide.
- Wall Plate Adapter.

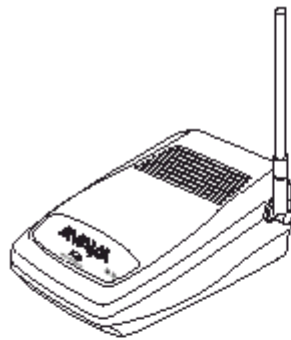

Base Unit



Handset



Telephone Cord

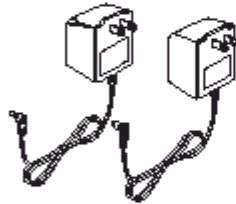

2 AC Adapters

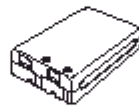

Rechargeable
Battery



Beltclip

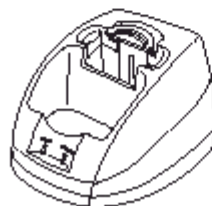

Charger Unit



Wall Mount Stand

VPN Phone Functionality

VPN Phone is a full-featured IP Telephony solution that provides secure communication over public ISP networks to an IP Office system at the company headquarters.

It is a software-only product that runs on the standard 5610/5620/5621 or 4610/21 IP telephones. In combination with one of these phones and the most popular VPN gateway products, the software extends enterprise telephony to remote locations.

VPN functionality is also supported on the new 9600 IP phones, not requiring a separate software load.

VPN Phones offer the full IP Office telephony features that are available on IP Office IP phones at the users desktop in a remote location like a home-office:

From release 6 onwards, no license for VPN functionality is needed for either 5600 or 9600 Series phones.

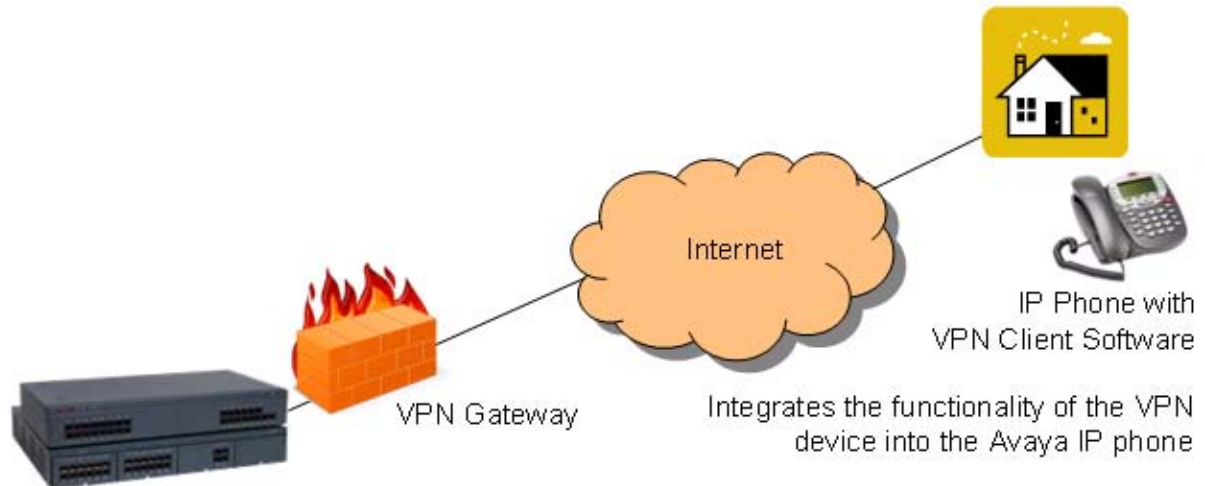

VPN Phone is ideal for IP Office customers supporting "work-at-home" users:

- Virtual Office workers
- Remote workers
- Remote call center
- Business continuity support
- Very small locations that require a single phone only
- Temporary installations such as conferences, off-site meetings, and trade shows

VPN Phone has been tested with a number of VPN-gateways from major vendors like Cisco or Juniper as well as with smaller VPN-access devices from companies like Adtran, Kentrox, Netgear, and SonicWall. Refer to the support pages (support.avaya.com) for a list of available application notes on VPN-gateways tested with each line of phones.

Analog Telephones

As well as providing a lower cost alternative to system specific telephones, analog telephones can still deliver a high degree of functionality on IP Office. They are particularly appropriate in applications where users require lower entry costs and can be used with Phone Manager for a high proportion of call control.

Analog telephones that are compatible with caller display functionality can display the telephone number of the calling party if available. Simple programming of IP Office can convert that numeric display in to the company name associated with that number.

Feature activation by analog telephones is via short codes. IP Office is pre-programmed with a default set of short codes but these can be changed to mimic a legacy telephone system as required.

Avaya would like to stress that although most analog phones will work on IP Office - Avaya cannot guarantee that all analog phones in every region of the world will work on the IP Office.

- Analog phones connect to IP Office via ports marked PHONE ports.

Avaya 6200 Analog Telephone (North America)

The 6200 range of telephones are single-line analog phones that require one tip and ring pair for operation. This series of telephones have a Ringer volume control on the side of the telephone and a Handset volume control on the front of the phone. They use DTMF dialing only and support the Positive Disconnect function. In addition, these phones have a Message light, a recall button that allows access to system features, a redial button that allows automatic redial, a hold button with a single associated light, and a data jack on the rear of the telephone. The 6219 phone adds 10 programmable dialing buttons and the 6221 phone adds a built-in speakerphone with mute capability.



Analog Telephone Features	6211	6219	6221
Programmable buttons (10 buttons)	✗	✓	✓
Program Keylock	✗	✓	✓
Pause	✗	✓	✓
Redial	✓	✓	✓
Speaker	✗	✗	✓
Flash	✓	✓	✓
Hold (with indicator light)	✓	✓	✓
System Hold	✗	✓	✓
Mute	✗	✗	✓
Handset Volume Control	✓	✓	✓
Ringing Volume Control (3 position)	✓	✓	✓
Ringing Patterns (2)	✓	✗	✗
Personalized Ringing	✗	✓	✓
Message Waiting Light	✓	✓	✓
Desk/Wall Mount	✓	✓	✓
Data Jack	✓	✓	✓
Colors	White/Grey	White/Grey	White/Grey
Ringer Equivalency	0.7A, 1.6B	0.5A, 1.5B	0.5A, 1.5B
Hearing Aid Compatible	✓	✓	✓
Positive Disconnect	✓	✓	✓
DTMF Dialing	✓	✓	✓
Specialty Handset Support	✓	✓	✓

Interquartz Gemini Phones (EMEA and APAC)

Avaya have tested the new generation Interquartz Gemini analog telephones with IP Office to ensure that telephone and system are compatible. The Gemini phones offer good value for money without compromising on quality. Their stylish design and rugged build quality make them a popular choice for buyers on a limited budget.

For sales enquiries and product information contact Interquartz at avaya-enquiries@interquartz.co.uk.

Basic telephone 9330-AV



- Visual Message Waiting Indication.
- Locking mute button with LED indicator.
- Last number redial.
- Recall button.
- Ringer volume adjust.
- Ringer indicator light.
- Wall mountable - no additional bracket required.
- Hearing aid compatible.
- Rubber feet to minimize slippage



All features of 9330-AV plus:

- Caller ID with 80 memories (shows date, time and new/repeat/answered/unanswered calls) .
- Large 3 line LCD display.
- IP Office feature activation through programmable keys.
- 100 name and number personal directory.
- 20 lockable direct access memories.
- Full handsfree working.
- Headset port.
- Switchable Time Break Recall 100 / 200 / 300 / 600 ms.
- Call timer.
- Alphanumeric keypad.
- Last number redial with 5 memories.



- Removable inlay card for personalized logo printing.
- Triple standard message waiting light (high voltage, reverse polarity and voltage drop).
- 10 non-volatile memories.
- Ringer indicator light.
- Ringer volume and pitch adjustment.
- Last number redial and Recall button.
- Hearing aid compatible.
- Wall mountable – no additional bracket required.
- ELR/TBR switchable.
- MF Only.

Doorphone Entry Systems for IP Office

Doorphones offer convenience and security. Depending on the needs of the environment, door phones may allow internal users to not only speak with someone who is outside, but also to easily allow the visitor entrance to the facility or residence. Doorphones can be connected to the Avaya IP Office base unit in a variety of ways, providing design flexibility based upon needs.

All of the IP Office base units include an external output port. Connections of doorphones to these ports enable the user to gain

access to the premises through default system short codes, through the optional Phone Manager Pro application, and through the optional VoiceMail Pro application. The flexibility of the IP Office provides the ability for short codes to be customized to a code more desirable for users. By using the Phone Manager Pro application, users can label the icons within the application a descriptive name such as Receiving Door or Front Door. The flexibility of VoiceMail Pro allows the visitor to enter a predetermined code from the phone granting access. This scenario is particularly useful in areas when co-workers are working at another site. Additionally, many doorphones can be connected to station or trunk ports available on IP Office.

The Avaya IP Office system offers three doorphone solutions to choose from:

- Avaya Universal Doorphone System (North America)
- Kalika Communications Doorphone Entry System (EMEA)
- Interquartz Doorphone (EMEA)

Avaya Universal Doorphone System:

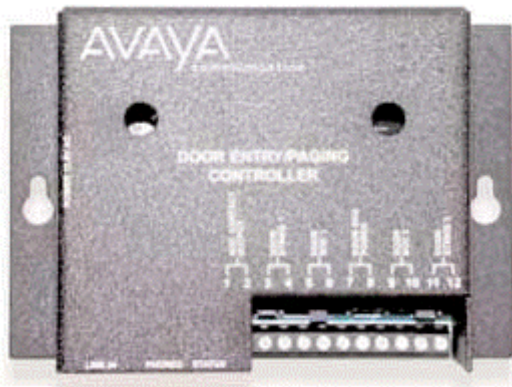

- System consists of a controller and a speaker.
- The speaker is mounted securely on the wall and is connected to the controller, which normally resides in the equipment room. The controller is connected to a trunk port.
- Users with the trunk appearance will be notified when a visitor has pressed the Push button located on the weatherproof speaker.
- Each controller supports two speakers, for example Front Door and Back Door.
- Custom ringing mode distinguishes doorphone calls from external calls.
- Call waiting tones indicate which doorphone is calling and distinguish a doorphone call from an external line call.
- Calls can be placed on hold when visitors call from the doorphone.
- Commercial or residential security is provided via two-way handsfree communication from a door or gate.

Kalika Communications Doorphone Entry System:



- Supports a doorway intercom system with up to 46 buttons.
- The system can be programmed to enable multiple extensions to answer and control the operation of the door and can be used with both single and multiple door entry systems.
- It is ideal for apartment complexes or where different companies occupy different floors and require their own unique door entry solution.
- The Kalika Communications Control Unit is available in several versions and is equipped to provide two-way voice communications, electrical lock control and label lamps.
- It is weatherproof and remotely programmable.
- For sales enquiries and product information contact Kalika Communications at info@kalika.co.uk.

Kalika also offers an RVI (Remote visual identification) application which can screen pop an image onto the Avaya browser based handsets. RVI is displayed frame by frame in a JPEG image form and is used as an identification tool. It is designed to complement the existing IP camera already supplied by Kalika.



Interquartz Doorphone:



- Choice of models (1, 2, and 4 button).
- Slim design (16mm thick).
- Strong aluminium casing.
- Optional PC configuration.
- Remotely programmable via DTMF.
- Connection via analog extension port or trunk port.
- Relay lock control.
- Backlit inlay cards.
- Internal heating system.
- Day/Night service.
- Combination lock control.
- For sales enquiries and product information contact Interquartz at support@analogphonesavaya.com.

Headsets

Avaya offers ergonomically designed communication headsets and amplifiers for the Avaya IP Office telephones. This full line of professional and contact center solutions set the standard in sound quality and durability. Avaya headsets are designed for maximum, all-day comfort and are available in styles that suit nearly any wearer and any usage pattern.

Whether you want the freedom to communicate handsfree while working at your desk, or the ability to roam while talking, you will find a solution that suits your individual needs.



Please check www.avaya.com for a current list of supported headsets.

Summary

All Avaya telephones are designed to ensure that features and functions are easily accessible to the user - ensuring that, through ease of use, the full benefits of the system are delivered to the desktop.

The phones that support handsfree operation are intended for individual use only, not for group and conference room operation.

The telephones listed below are the preferred and premier range of telephones for use on the IP Office. These telephones are sold worldwide in every country that the IP Office is available. This telephone range consists of both digital and IP telephones.

IP Office worldwide digital phones:	IP Office worldwide IP phones:
• 1403 Telephone [69]	• 9620L/9620C IP Telephone [60]
• 1408 Telephone [71]	• 9630G/9640/9640G IP Telephone [62]
• 1416 Telephone [73]	• 9650/9650C IP Telephone [64]
• 5402 Telephone [77]	• 1603 IP Telephone [68]
• 5410 Telephone [80]	• 1608 IP Telephone [68]
• 5420 Telephone [82]	• 1616 IP Telephone [68]
	• 5610SW IP Telephone [80]
	• 5621 IP Telephone [82]

In addition to the telephones above, the IP Office supports a wide range of phones as listed below. However, note that some of these phones are only available in certain countries and regions.

Other digital/analog phones:	Other IP phones:
• T3 Compact (Upn and IP) [85]	• 3641 Ruggedized Wireless (WiFi) Phone [103]
• T3 Comfort (Upn and IP) [87]	• 3645 Ruggedized Wireless (WiFi) Phone [104]
• T3 Classic (Upn and IP) [86]	• 3701 IP DECT Wireless Handset [110]
• T3 DSS Module [88]	• 3711 IP DECT Wireless Handset [111]
• 2402 Telephone [77]	• 3720 DECT R4 Wireless Handset [105]
• 2410 Telephone [80]	• 3725 DECT R4 Wireless Handset [106]
• 2420 Telephone [82]	• 3810 Wireless Telephone [112]
• EU24/EU24BL DSS Unit [84]	• 4610SW IP Telephone [80]
• Analog Telephones [113]	• 4621SW IP Telephone [82]
• Interquartz Gemini 9281-AV, 9330-AV and 9335-AV analog telephones [117]	

The following phones are fully supported on IP Office R6 but are no longer available for new sales.

Other digital/analog phones:	Other IP phones:
• 6408D Telephone	• 5601 IP Telephone
• 6416D Telephone	• 4601 IP Telephone
• 6424D Telephone	• 4602SW IP Telephone
• XM24 DSS Unit	• 5602SW IP Telephone
• 20DT DECT Telephone (with IP DECT only)	• 4610SW IP Telephone
• 4606	• 5620 IP Telephone
• 4612	• 4620/21 IP Telephone
• 4624	• 4625SW IP Telephone
• 4450 DSS Unit	• 3616 Executive Wireless (WiFi) Phone
	• 3620 Healthcare Wireless (WiFi) Phone

- For maximum cabling distances please refer to the IP Office Installation Manual.

Legacy Telephone Support

The following telephones are not supported by IP Office Release 6. They may function but have not been tested with IP Office Release 6 and any faults reported with IP Office Release 6 will not be fixed.

- 20DT Analog DECT used with IP Office Analog DECT and Compact DECT.
- TransTalk 9040

Chapter 5.

Features

5. Features

IP Office provides a comprehensive telephony feature set to enable a fast and efficient response to a telephone call. Features such as Caller ID display and call tagging allow employees to see who is calling and who they are calling before they pick the call up. Client information can even be 'popped-up' on the user's PC.

For those who are not tied to a desk, Wireless handsets and twinning offer mobility around the office. For those out of the office, be it on the road or working from home, comprehensive and easy to use call forwarding facilities, PC Softphone and a remote access service allow them to remain in telephone contact and access centralized resources at all times.

Incoming calls can be efficiently handled using either Direct Dialling (DDI/DID) or dedicated operators. For out of hours calls or times when you just can't take calls, IP Office provides voicemail and optional Auto-Attendant services.

Basic Call Handling

Tones

IP Office generates the correct user tones for the geography. These tones are generated for all IP Office extension types, analog, digital and IP.

Supported tones are:

- Dial, both primary and secondary depending on geography
- Busy
- Unobtainable
- Re-order
- Conferencing tone depending on geography

Caller ID

Feature

- Display of the caller's number on incoming calls, where supplied by the service provider.
- Sending of calling number on outgoing external calls.

Benefit

- Confirmation and recognition of who is calling.
- Storage of Caller ID numbers for return calls.
- Directory name matching to Caller ID numbers.
- Screen-Popping customer records in compatible applications.

Description

Where supplied by the service provider, the IP Office can receive and use the callers Caller ID. The Caller ID is passed through to the answering phone or application and is included in any call log or history supported by the phone or application. If the Caller ID matches a number in the IP Office's Directory, the matching directory name is shown instead of the number.

Where IP Office Phone Manager, or the TAPI service is used to link to database software on the users PC, it is possible to have an automatic query performed on the supplied Caller ID and have the caller's record in front of the user before the call is answered.

For outgoing calls the IP Office can insert a system wide Caller ID or set a flag to have Caller ID withheld. For users with a direct dial number routed to their extension, that direct dial number is also used as their Caller ID for outgoing calls. Alternatively short codes can be used to specify the Caller ID that should be sent with outgoing calls.

Note that the sending and receiving of Caller ID is subject to the service provider supporting that service. The service provider may also restrict which numbers can be used for outgoing Caller ID.

Hold

A call may be placed on hold with optional Hold music. A held call cannot be forgotten as it is presented back to the extension after a timeout set by the system's administrator.

See also [Park](#)^[128].

Toggle Calls

Toggle Calls cycles round each call that the user has On Hold to their extension locally within the system, presenting them one at a time to the user

Hold Call Waiting

Hold Call Waiting is a compound feature combining hold and answer and provides a convenient way to hold an existing call and answer a waiting call through a single button press.

Hold Music (Music on Hold)

The IP Office system supports up to 4 sources of music on hold - one system source which may be external, internal (WAV) or tone, plus up to 3 additional internal sources. The internal sources are .WAV files saved either in volatile memory, or on the optional memory card in an IP500 and IP406 V2. The .WAV file must be 16bit PCM mono and sampled at 8Khz with a maximum duration of 30 seconds.

Alternate sources for music on hold are selectable for use by Incoming Call Routes or Hunt Groups. On IP500 systems, each source can be up to 90 seconds long (30 seconds on IP406 V2 and IP412).

External music on hold sources connect to the 3.5mm Audio socket on all IP Office control units.

Park

As an alternative to placing a call on hold, a call can be parked on the system to be picked by another user.

The call park facility is available through the user's telephone, one-X Portal for IP Office, Phone Manager or SoftConsole. Calls are Parked against a 'park slot number' which can be announced over a paging system so the person the call is for can go to any phone and collect the call by dialling the park slot number.

For convenience Phone Manager has 4 pre-defined park buttons. On digital phones with DSS/BLF keys it is possible to program Park keys that will indicate when there is a call in a particular park slot and allow calls to be parked or retrieved.

There is a system configurable timeout that determines how long a call may remain parked before it is re-presented to the extension that originally parked the call.

Automatic Callback

Feature

- When calling an extension that is busy, set the system to call you when the extension becomes free. This feature is also called "Ringback When Free".
- When calling an extension that just rings, set the system to call you when the extension is next used. This feature is also called "Ringback When Next Used".

Benefit

- Carry on with other work and let the system initiate a call for you when the extension becomes available.

Description

Depending on the type of phone a user has, call back when free is accessed by dialing a short code while listening to internal busy tone, selecting an option from an interactive menu or pressing a programmed DSS/BLF key. Callback when free can also be activated from Phone Manager.

You can also set a callback when free or a callback when next used using a short code without attempting a call.

Note that a user can only have one automatic callback set at any one time.

This feature is supported across the [IP Office Small Community Network](#) ¹⁸³.

Direct Inward Dialing (DID/DDI)

This relies on the local telephone exchange passing all or part of the dialed number to the IP Office. This number can then be used by IP Office call routing software to route the call to an individual phone, or groups of phones. This service is typically used to reduce the workload on a reception position by giving members of staff or departments individual numbers so they can be called directly. For convenience it is common to have the extension or group number the same as the digits supplied from the network, but IP Office can convert the number to what ever number is needed by the business, within limits

In North America, T1 circuits are required for DID.

Transfer

Call Transfer allows users to transfer a call in progress to another phone number – either internal extension or external public number. The caller is placed on hold while the transfer is performed.

If the phone is put down before the destination has answered, the original caller will be automatically transferred. This is called an Unsupervised or Blind Transfer. Alternatively, a user can wait for the destination to be answered and announce the transfer before hanging up to complete the transfer. This is called a Supervised Transfer.

Unless restricted by the system administrator, the IP Office makes no differentiation between internal or external call transfers.

Distinctive and Personalized Ringing

The IP Office uses different ringing sequences to indicate the type of call, for example whether internal or external. This feature is called 'distinctive ringing'. For analog phones the distinctive ringing sequences used are adjustable. For digital and IP phones the distinctive ringing sequences are fixed as follows;

- Internal Call: Repeated single-ring.
- External Call: Repeated double-ring.
- Ringback Call: Single ring followed by two short rings.

This ring is used for calls returning from park, hold or transfer. It is also used for call back when free and voicemail ringback calls.

This feature is supported across the [IP Office Small Community Network](#) ^[183].

Personalized Ringing

In IP Office the term personalized ringing is used to refer to changing the sound or tone of a phone's ring. On many Avaya digital phones, the ringer sound can be personalized. Changing the ringer sound does not alter the ring sequence used for distinctive ringing. This feature is local to the telephone and not supported on all types of telephones.

Message Waiting Indication

Message waiting indication (MWI) is a method IP Office uses to set a lamp or other indication on compatible telephones when a new message has been left for the user, either in a personal voice mailbox or in a group mailbox or call back message. When the message has been played or acknowledged, the lamp is turned off.

All Avaya digital and IP phones have in-built message waiting lamps. one-X Portal for IP Office and Phone Manager also provide message waiting indication on screen

For analog phones, from IP Office 3.1 a variety of analog message waiting indication (MWI) methods are provided. Those methods are 51V Stepped, 81V, 101V and Line Reversal. The MWI method must be selected from the IP Office Manager when configuring a system to match the properties of the analog phones. Note that the 101V signaling is only available on IP500 Phone cards and expansion modules plus version 2 IP400 Phone 8, 16 and 30 expansion modules, not on the IP406 V2 control unit.

Visual Voice

Feature

- Provides interface to voicemail through handset display and buttons e.g. Listen, Save, Delete, Fast Forward.

Benefit

- Quick access to voicemails and commonly used messaging features.

Description

You can access and control voice messages via the display on Digital or IP phones. Visual Voice requires Preferred Edition or Essential Edition, and can only be used with large display LCD sets only from the 1400, 1600, 2400, 5400, 4600, 5600, 9600 and T3 series. (1403, 1603, 1603SW, 2402, 5402, 4601, 4602SW, 5601, 5602SW do not support Visual Voice).

The fixed message button on certain phones can be configured to invoke visual voice (this is the default setting for new configurations). This configurable option frees the button programming required currently for Visual Voice.

Features supported are:

- access new/old/saved messages for personal and hunt group mailboxes.
- next and previous message.
- fast forward and rewind.
- pause message.
- save, delete and copy message to other users of the system.
- change default greeting.
- change password.
- change email settings (Preferred Edition only).

Advanced Call Handling

Description

In larger businesses or businesses with greater reliance on the telephone for internal and external communications some of the more advanced features will improve efficiency and customer service. Features like Pick-Up which permit users to take a call for a colleague who is temporarily away from their desk, of Absence Text which can quickly give information to internal callers about a person's availability.

Absence Text

Feature

- Display a text message on the user's phone and IP Office Phone Manager application.
- Display the same message on other internal phones and IP Office applications when calling the user.

Benefit

- Inform other internal users of your current status and likely availability.

Description

Any user can set Absence Text on their phone, even users of standard analog phones, but it can only be displayed on selected display phones, Phone Manager and SoftConsole that call the user. Most supported feature phones give the option of adding some text, for example, "At lunch until 16:00".



When a user has an absence text message set, call processing is not affected to the user and they still have the choice of using features like Do Not Disturb or Forward on No Answer as appropriate. Phones that support the interactive setting of Absence Text will also display it on the users own phone for the benefit of people who come to their desk. There are 10 predefined strings for Absence Text:

- None (no text message)
- "On vacation until"
- "Will be back"
- "At lunch until"
- "Meeting until"
- "Please call"
- "Don't disturb until"
- "With visitors until"
- "With cust. til"
- "Back soon"
- "Back tomorrow"
- Custom

All may have additional text entered, eg message 4 plus 10:00 will show "Meeting until 10:00" and the text strings are localized to the system language

This feature is supported across the IP Office Small Community Network

Call Tagging

Feature

- Display a text message on the user's phone, one-X Portal for IP Office or Phone Manager, when a call is presented to it.

Benefit

- Provide additional information about the call.

Description

This feature is used to provide additional information about the call to the targeted user before they answer it. Call Tagging may be used when transferring a call from one-X Portal for IP Office, Phone Manager or Soft Console to give caller info if the user doing the transfer is not able to announce the call.

It is possible to add a tag to a call automatically using CTI and IP Office VoiceMail Pro. This is also possible based on an Incoming Call Route. On some telephones, displaying the Tag may mean that it is not possible to display the usual call source and target information.

Reclaim Call

Feature

- The ability to recover, or reclaim, the last call that was at your phone but is now ringing or is connected elsewhere.

Benefit

- If you just miss a call and it goes to voicemail or call coverage, you can get the call back while it is still being presented or connected through IP Office

Description

This is a special version of the Acquire Call feature that only applies to the last call at your extension.

Hunt Group Enable/Disable

Feature

- The ability for a user to enable or suspend their membership of hunt groups.

Benefit

- A user may need to temporarily join or leave individual hunt groups, for example to cover a peak of calls without changing the system programming.

Description

A team supervisor or administrator may not usually take calls for a team but at times of high traffic they may join the group to take calls and when the peak is over leave the group to resume their regular tasks. To use this feature the User must be configured as a member of the hunt group by the systems administrator, it is not possible for a user to arbitrarily join a hunt group that they have not been identified as a member of.

Call Waiting

A User may not want people calling them to receive busy tone if they are already on another call, but have the call receive ring tone and have some kind of alert that there is a call waiting. The user can then decide to finish or hold the current call and answer the one that is waiting. The amount of information that is available about the call that is waiting depends on the type of phone the user has, or if they are using one-X Portal for IP Office or Phone Manager.

As Call waiting tone can be disruptive it is possible to turn the feature on or off and even suspend it for a single call – useful for conference calls.

Do Not Disturb (DND)

This is the ability to temporarily stop incoming calls ringing at a user's telephone. It will prevent the user from receiving hunt group calls and give direct callers either voicemail (if enabled) or a busy signal. This feature can be enabled/disabled from the phone or via one-X Portal for IP Office or Phone Manager.

It is possible to have some calls bypass the DND setting and ring the phone. For example a manager might have their secretary's extension number on the DND exceptions list. The exceptions list can be easily managed by the one-X Portal for IP Office or Phone Manager. Both internal and external numbers can be on the exception list.

Dial Plan

IP Office has a very flexible numbering scheme for extensions, hunt groups and feature commands. While the system has default numbering for feature codes and extensions, they can all be re-defined. Default extensions and hunt groups have 3 digit numbers starting at 200 but these can be changed from 2 to 9 digits through the IP Office Manager. There is a default set of feature access "short codes," but these can be changed to what ever the end user requires, within limits. This is useful for example, if IP Office is replacing a system where DND was accessed by dialling *21, it is possible to change the IP Office Short Code to mimic the code of the replaced system.

In certain countries IP Office can support a Secondary Dial Tone when an access digit is dialled, though this limits some functionality like Alternate Route Selection (ARS). IP Office can also be configured to work without line access digits, by analyzing digits as they are dialled and determining if they are for an internal number or should be sent out on a line – this is valuable in SOHO installations where users will not necessarily be used to dialling an access digit for an outside line.

Paging

All Avaya digital and IP phones supported on the IP Office that have loudspeakers can be used to receive broadcast audio messages without having to install a separate paging system. Paging can be to individual phones or groups of phones.

Analog extension ports can be configured for connection to external overhead paging systems, usually through an adapter, such that a port can be included in a paging group to permit mixed phone and overhead paging.

Some Avaya digital and IP phones are able to answer a page by pressing a key while the page is going on, this terminates the page and turns it into a normal call.

This feature is supported across the IP Office Small Community Network

Intrude

The Call Intrude feature allows a user, if permission through IP Office Manager is given, to join an existing conversation whether this is an internal or external call.

A user with the "Can Intrude" option can join a call on any extension on the system, however, a User with "Cannot be Intruded" setting would prevent others from joining their call.

Inclusion

This feature enables selected users to intrude on calls that are already in progress. The intruding party intrudes on the existing call and all parties hear a tone. The speech path is enabled between the intruding party and the called user; the other party is forced onto hold and will not hear the conversation. On completion of the intrusion the called party speech path is reconnected to the original connected party. The feature is enabled or disabled on a per user basis through the Manager.

Private Call

Users can set a status of private call using short codes or a programmed button. Private calls cannot be recorded, intruded on, bridged into or monitored.

Hot Desking

Hot Desking allows a number of users non-exclusive use the same extension. Each user logs in with their own identity so they can receive calls and can access their own Voicemail and other facilities. For example, sales personnel who visit the office infrequently can be provided with telephony and Voicemail services without being permanently assigned a physical extension. When finished, they simply log out to make the extension available to others or if users log in at another phone, they are automatically logged out of the original extension.

Remote Hot Desking

Feature

- The ability for a user to Hot Desk to other locations within the Small Community Network.
- Available on Digital, Analog and IP phones.

Benefit

- A user can make and receive calls from any office as if using the phone on their own desk.
- Single number, improved mobility and easy access to familiar features.
- the user has access to the centralized system and personal directory as well as their call log (1400, 1600, 9600 Series and T3 phones only).
- Great for consultants, managers, lawyers working on different offices on different days.

Description

IP Office supports remote hot desking between IP Office systems within a Small Community Network (SCN). The system on which the user configured is termed their 'home' IP Office, all other systems are 'remote' IP Offices. No additional licenses are required to support Remote Hot Desking other than the Voice Networking license on each IP500 within the SCN.

- **User Settings**
When a user logs in to a remote IP Office system, all their user settings are transferred to that system.
 - The user's incoming calls are rerouted across the SCN.
 - The user's outgoing calls use the settings of the remote IP Office.
 - However some settings may become unusable or may operate differently. For example if the user uses a time profile for some features, those feature will only work if a time profile of the same name also exists on the remote IP Office.
- **Break Out Dialing**
In some scenarios a hot desking user logged in at a remote system will want to dial a number using the system short codes of another system. This can be done using either short codes with the Break Out feature or a programmable button set to Break Out. This feature can be used by any user within the Small Community Network but is of significant use to remote hot deskers.

Note: Remote Hot Desking is not supported for use with Customer Contact Center (CCC) or Customer Call Reporter (CCR). Features handled by the telephone itself are not affected by Hot Desking (e.g. call log and phone speed dials).

Relay On/Off/Pulse

IP Office is fitted with two independent switch outputs for controlling external equipment such as door entry systems. Control of these switches is via allotted handsets allowing the switches to be opened, closed or pulsed as required. Control of switches is also accessible via Phone Manager Pro, SoftConsole and VoiceMail Pro.

Pickup

Call Pickup allows a user to answer a call presented to another extension. Types of call pickup include:

- Pick up any call ringing on another extension.
- Pick up a hunt group call ringing on another extension, where the user must be a member of that hunt group.
- Pick up a ringing call at a specified extension.
- Pick up any call ringing on another extension that is a member of the hunt group specified.

This feature is supported across the IP Office Small Community Network

Call Recording

Where IP Office has VoiceMail Pro installed it is possible to record a call and save the recording to the user's mailbox, a group mailbox or the voice recording library. For example, this is useful when a caller is going to give detailed information like an address or phone number and the caller will hear a warning message or tone that the call is being recorded in some countries. Where call recording is required for Quality Assurance, it is possible to set the IP Office system to automatically record a percentage of calls for later review.

Beginning with IP Office R4.0, any call (normal, conference, or intrusion) and any phone type (including IP) can be recorded. Where "advice of recording" needs to be played, IP Office will ignore Voicemail port licensing if an insufficient number of voicemail channels have been licensed.

Note: for IP phones, a VCM channel will be required for the duration of the recording.

Telecommuter Mode

Phone Manager Pro allows the making and receiving of calls and the retrieving of voicemails from an external phone number as if they were in the office, with Phone Manager providing the call control. The typical scenario is the remote worker that occasionally works from home or from a hotel room.

This feature also provides billing convenience and potential cost savings for remote workers and mobile work force as all the calls are established by IP Office: there is no need to check bills, nor to pay for expensive hotel calls.

Twining and Mobility

Twining allows a primary extension and a secondary number (extension or external) to operate together as a single telephone. When a call is presented to the primary phone the secondary will ring. If the primary telephone does not ring, for example in Do Not Disturb, the secondary phone will not ring.

Internal Twining

This is typically used in scenarios like workshops or warehouses where team supervisors may have a desk with a fixed phone but also have a wireless extension (e.g. DECT). When a call is made from either twinned phone, the call will appear to have come from the primary phone (when the secondary is an extension on the IP Office system). Other users of the system need not know that the supervisor has two different phones. The supervisor's Coverage Timer and No Answer Time are started for the call and if the call is not answered within that time, the call will be delivered to available coverage buttons (if applicable) and then Voicemail (if applicable).

The following features are supported with internal twining

- Follow Me To
- Follow Me Here
- Forwarding
- Do Not Disturb (inc exceptions)
- Context less hunt group actions: Membership / Service Status / Fallback Group configuration
- Voicemail On / Off / Access
- Call Log (Central Call Log for T3 and 1600 phones only)
- Redial (Central Call Log for T3 and 1600 phones only)
- Personal Directory Entries (for T3 and 1600 phones only)

Mobile (external) Twining

A typical use for Mobile Twining would be for a salesperson who has a desk extension but is often out of the office. They can give out one phone number to clients, but it will ring their mobile/cell phone as well as the desk extension. External mobile devices can be set as twining targets even if the primary telephone is logged out (e.g. in the case of a "virtual" extension).

From IP Office 4.2 onwards, the following additional Mobility features are available in addition to simple mobile twining (but need to be separately enabled per user in IP Office Manager):

Mobile Call Control

This allows a user who has answered a twinned call on their mobile cell phone to dial a DTMF sequence ** (star-star) to put the call on hold and receive IP Office system dial tone. The user will then be able to perform supervised and un-supervised transfers, shuttle (switch between held calls), and conference (Conference add and transfer to a meet-me conference).

Mobility Callback

This feature, available from Release 6, allows a user to make an outgoing call from IP Office from their mobile phone. The user dials a specific number on the IP Office system which rejects the call and then calls the mobile phone back. On answering, the user is presented with dial tone and can proceed to dial as with Mobile Call Control. The benefit is that in some territories the initial call from the mobile phone will be free since it is never answered, enabling centralized billing and greater control over costs.

Avaya one-X Mobile Client Support

IP Office supports the Avaya one-X Mobile 'Single Mode' Client running on selected Symbian Single-Mode or Windows Mobile 5 or 6 handsets. This provides a graphical interface for call control and allows a one-number service for both incoming and outgoing calls. For a full list of supported handsets see <http://support.avaya.com>. IP Office systems supporting one-X Mobile require a dedicated DID/DDI number for each feature required (e.g. hold, transfer).

Mobile Call Control and one-X Mobile support require twinned calls to be routed through specific trunk types on IP500/IP500 V2 only:

- IP500 PRI-U (single or dual) daughter cards

- IP500 Dual or Quad BRI daughter cards
- SIP trunks (RFC 2833)

In IP Office Release 6, the Mobility features are available to users with either a Mobile Worker or Power User license.

With either internal and external twinning, users may be allowed to enter a twinned number, or may just be able to activate/deactivate the twinning function depending on administrative settings. Such user activation can be achieved through deskphone buttons, Phone Manager or VoiceMail Pro.

The following types of calls are eligible for twinning:

	Internal twinning	External (mobile) twinning
Any internal call on a Call Appearance button	✓	✓
Internal or external calls transferred to the extension	✓	✓
Direct Dial calls to that extension	✓	✓
Hunt group calls	✓	✓
Calls forwarded from another extension	✓	✓
Line Appearance calls (configurable)	✓	✗
Bridged Appearance calls (configurable)	✓	✗
Coverage calls (configurable)	✓	✗
Automatic Intercom calls	✓	✗
Returning transferred, held or park calls	✓	✓*
Callback calls from the system (Transfer and Park Return)	✓	✗
Paging calls	✓	✗
Follow Me calls	✓	✗

*Requires IP500/IP500 V2 BRI, PRI or SIP trunks and Mobile Call Control to be enabled for that user.

Key and Lamp Operation

IP Office offers a full range of Key and Lamp features on Avaya feature phones. These features include; Line Appearance, Call Appearance, Bridged Appearance and Call Coverage. As these features require a phone with buttons and indicators, the features are only supported on certain Avaya digital and IP phones. Key and Lamp operation is not supported on analog phones.

IP Office can have a ring delay set on each appearance button to allow time for the target number to answer before other extensions ring, or visual alert only without ring.

In Key and Lamp operation, IP Office supports up to 10 buttons on each telephone and 10 telephones with the same line appearance.

Appearance Buttons

Feature

- Use the programmable buttons available on Avaya digital and IP telephones to represent individual calls.
- Answer, originate and join calls by pressing the appropriate appearance buttons.

Benefits

- Indication of calls connected and calls waiting.
- Handling of multiple calls from a single phone.

Description

Many Avaya digital and IP telephones supported by IP Office have programmable buttons. These buttons can be assigned to appearance functions that allow the handling of calls. These functions are:

- Line Appearance Buttons
Used to indicate make and answer calls on a specific external trunk.
- Call Appearance Buttons
Used to handle multiple incoming and outgoing calls from a user's extension.
- Bridged Appearance Buttons
Used to match the call appearance buttons on a colleagues extension.
- Call Coverage Buttons
Used to indicate unanswered calls ringing at a colleagues extension.

Line Appearance

A Line Appearance is a representation of a trunk line on the IP Office system where the indicator tracks the activity on the Line. Only external calls can be answered or made on Line Appearances. Line appearances can be used with Analog, E1 PRI, T1 PRI and BRI trunks PSTN trunks. They cannot be used with E1R2, QSIG and IP trunks.

Call Appearance Buttons

Feature

- Uses a programmable button on the Avaya digital and IP telephone to represent an incoming or outgoing call.
- Separate buttons are used to represent each simultaneous call that the user can make or answer.
- Where possible, the status of the calls (ringing, connected or held) is indicated by the button indicator.

Benefit

- Call appearances allow a single user to make, answer and switch between multiple calls by pressing the appropriate call appearance button for each call.

Description

On Avaya IP Office digital and IP telephones that have programmable buttons, those buttons can be set as call appearance buttons through the IP Office Manager. The number of call appearance buttons set for a user determines the number of simultaneous calls they can make and answer.

Note that the use of call appearance buttons overrides IP Office call waiting features. It is only when all call appearances are in use that subsequent callers receive either busy tone, voicemail or follow a forward on busy action

When call appearance buttons are used, a minimum of three call appearance buttons is recommended where possible, although some phones are restricted to two call appearance buttons by the number or design of their programmable buttons.

Alerting/Ring Tone for Covered Calls

Feature

- The alert signal (ring tone) for incoming calls for covered phones can be set to the following values: Ring (default), Abbreviated Ring and No Ring.

Benefits

- The ability for a user to choose how the covered call will alert.
- To keep the alerting noise low in open-plan offices.

Bridged Appearance Buttons

Feature

- Allow the user to have an appearance button that matches another user's call appearance button.

Benefit

- Answer and make calls on behalf of the other user.
- Audible indication of calls presented to the bridged user, where programmed
- Visual indication of when the other user has calls presented, held or connected.
- Join and exchange calls using the paired call appearance and bridged appearance buttons.

Description

A bridged appearance button matches the activity on one of another user's call appearance button. For example, when the call appearance shows a ringing call, the bridged appearance button will also show the ringing call and can be used to answer that call.

Similarly, if the bridged appearance button is used to make a call, the call activity is shown on the matching call appearance button. The call appearance button user can join or takeover the call using their call appearance button.

Bridged appearance buttons allow paired 'manager/secretary' style operation between two users, and are only supported for users who have call appearance buttons.

Call Coverage

Feature

- Allow unanswered calls to alert at other user extensions and be answered there before being forwarded or going to voicemail.

Benefit

- Provide users the opportunity to answer colleague's unanswered calls before they go to voicemail.

Description

When a user has an unanswered call ringing, after a configurable delay, the call will also start alerting on any call coverage buttons associated with the user on other extensions. The call can then be answered by pressing the call coverage button. If still unanswered the call is forward or goes to voicemail as normal.

The time a call rings before also alerting on any associated call coverage buttons can be adjusted for each user.

External Call Lamp Indication

Feature

- New system wide configuration parameter to select the LED flash pattern for external calls on Bridged and Coverage appearances.

Benefit

- The user can determine if the covered call is internal or external.

Outbound Call Handling Features

Every business needs to make calls, but depending on the type of business these calls may need to be treated in a special way, such as recorded against a project or client through the use of Account Codes. A business may have several sites linked via a private network but certain users, like customer services agents, may need to be able to call colleagues in other offices even when the network is busy, while other users can wait for a line to come free, Least Cost Routes can automatically translate the internal number to a direct dial call over the public network while other users wait.

Account Codes

Feature

- Associate an account code with a call.
- Validate account codes used against list stored by the IP Office.
- Include the account code used with call log details.

Benefit

- Through the call records, group calls by account code for the purpose of call costing and tracking.
- Restrict outgoing calls by requiring users to enter a valid account code.

Description

IP Office stores a list of valid account code numbers. When making a call or during the call, the user can enter the account code they want associated with that call. IP Office will check the account code against its list of valid codes and request the user to re-enter the code if it is not valid. For incoming calls, the Caller ID can be used to match it with an account code from the IP Office's list of valid codes and report the account code with the call for billing.

Individual users can be set to Forced Account Code operation where they are required to enter a valid account code before making external calls. By using IP Office Short Codes it is possible to identify certain numbers or call types as requiring a valid account code before permitting the call to proceed, for example long distance or international numbers. Analog phone users can only enter account codes before making a call or in response to an audible system prompt to enter a code when making the call.

Account codes can also be entered through the one-X Portal for IP Office and Phone Manager. A system wide setting determines whether Phone Manager will display a list of account codes from which the user can select the code required or will hide the account code list.

In all the cases above, the account code entered is included with the call details in the IP Office's call record output. (SMDR).

Authorization Codes

Authorization codes allow an IP Office user to go to another extension on the system and make calls using their personal toll restrictions; this may grant the user greater or fewer privileges than the normal owner of the extension they use. Since Authorization Codes are independent of Account Codes, the user has to enter both if the required by the system configuration. All entered codes are logged in SMDR.

Dial Emergency

Dial emergency is an IP Office Short Code and, permits certain numbers to be dialed regardless of call barring or a phone being logged out.

Call Barring

Feature

- It is possible to prevent or allow calls to certain numbers such as international numbers or premium rate numbers for individual users or on a system wide basis.

Benefit

- Restrict the dialing of specific numbers or types of numbers system wide.
- Restrict certain users from dialing specific numbers or types of numbers.

Description

IP Office supports call barring at many levels. Short codes can be used at the system or individual user level to block the external routing of specific numbers or types of numbers. Typically the barring short codes are set to return busy tone, however they could route the call to an alternate number or to a Voicemail service that returns a 'barred dialing message'.

For users, the short codes can be allocated to a User Rights template. This template is then applied to the Users whose calls need restriction. In addition to barring the dialing of certain numbers, IP Office can be set to bar the forwarding of calls to external numbers on a per user basis.

Alternate Route Selection (ARS)

IP Office supports Alternate Route Selection, which is more flexible and easier to configure than Least Cost Routing (LCR). If a primary trunk is unavailable, then ARS provides automatic fallback to an available trunk (e.g., analog trunk fallback if a T1 or SIP trunk fails, or use PSTN for SCN fallback).

By configuring ARS, calls may be routed via the optimum carrier. Time profiles can also be used to allow customers to take advantage of cheaper rates or better quality at specific times of day.

Multiple carriers are supported. For example, local calls are to go through one carrier between specific hours and international calls through an alternative carrier. Carrier selection using 2-stage call set up via in-band DTMF is possible. It is possible to assign specific routes on a per user basis, e.g. only allow expensive routes to be used by critical staff.

Note: Existing LCR configurations are automatically converted to ARS when upgrading to 4.0

Maximum Call Length

This feature allows the system to control the maximum duration of any call based on the dialed number. This could be used for controlling calls to cellular networks or data calls made over the public network to ISPs.

PIN Restricted Calling

See [Account Codes](#) ⁽¹⁴⁾.

Transferable Dial Out Privilege

Feature

- A privileged user (Operator / Supervisor) can transfer an outside line (external dial tone) to a user that does not have external privileges.

Benefits

- Provides the company with control over external calls
- Provides the ability to provide outside line access for restricted phones . (e.g., those in public areas or conference rooms)

Idle Line Preference

Feature

- Going off hook will select the first Idle line appearance and the user will be connected to an outside line.

Benefit

- Provides the ability to select a specific external line (for companies that prefer to work in key-system mode)

Forwarding

This is the ability to forward a user's calls to another extension or external number such as a Mobile/Cell Phone. Calls can be forwarded in a number of ways and if the call is not answered at the forward destination it will go to IP Office voicemail if enabled for the user and call supervision is available. There are three separate forward destinations, one for forwarding on busy one for no answer and one for forward unconditional. Once the numbers have been entered, the user can toggle the forwarding to be active or not as required without having to re-enter the numbers.

If the user is a member of a hunt group, some types of hunt group calls can also follow forward unconditional. Users can select if forwarding is applied to external calls only, or all calls. Call forwarding is processed after Do Not Disturb and Follow-Me conditions are tested.

Associated Features

- Do Not Disturb (DND)
- Voice Mail (VM)
- Follow Me
- Hunt groups
- No Answer Interval

Precedence

- Forward Unconditional
- Forward Busy
- Forward No Answer

Coverage to Operator

Feature

- An operator or a group of operators can be configured to provide coverage for external calls that would otherwise go to voicemail.

Benefit

- Any unanswered calls will be routed to an operator or a Group of operators. For example, local government offices prefer to provide a personal service (rather than voicemail).

Forward on Busy

If enabled, this forward will be triggered when the user is busy and another call is routed to them, but does not include calls for a hunt group that they may be a member of. A user is normally considered to be busy when they are on a call but depending on call waiting settings and key and lamp features this may not be the case.

Forward on No Answer

This forward is triggered if a call has been ringing for a user but they haven't answered it within the configured answer time, this includes calls that have been indicating call waiting if enabled.

Forward Unconditional

This sends all calls for the user to the forward unconditional number, but if the call is not answered within a user's timeout period the call will be sent to IP Office voicemail, if enabled.

Unconditional Forward to Voicemail

Feature

- The ability to forward calls to Voicemail, even when the user's voicemail is not activated.

Benefit

- This feature allows a user who is familiar with the existing IP Office functionality of diverting all calls to a person or a group to follow the same pattern and divert all calls to a voicemail box.

Forward Hunt Group

Calls for a hunt group that the user belongs to can also follow forward unconditional. The hunt group must be set for either hunt or rotary ring type and if the call is not answered at the forward destination it will follow the hunt group call handling instead of going to voicemail. This can be particularly useful in a sales or support environments where a number of people may be out of the office on Mobile/Cell Phones and still participate in the hunt group as if in the office.

Follow Me

Follow-Me is similar to Forwarding except that the destination can only be an extension on the same IP Office as the user making use of the feature. Follow-Me is typically used when a user is going to be working away from their desk, for example in a workshop. All the call settings the user has on their main phone will apply to calls that follow the follow-me feature, including forward on busy or no answer.

Follow-Me can be set either from the users main phone – Follow-Me To – or from the phone where they want calls to be received – Follow-Me Here. Several people can have their phones forwarded to a follow-me destination and if the phone has a display it will indicate who the call is for.

Avaya Digital and IP Phones

Programmable Buttons

As well as the usual dialing keys, Avaya digital and IP phones have dedicated function buttons like Mute, Volume, Hold, Conference and Transfer. In addition to these, on many Avaya digital and IP phones there are keys that can be programmed with a range of selected special functions. These keys can be used for calling other extensions on the system (Direct Station Select or DSS keys), or can be used for options from speed dialing numbers to controlling features such as Do Not Disturb. Many features use an indicator to show whether a feature is enabled. Button programming is done through the IP Office Manager as part of the system configuration, although some phones allow the user to program buttons and functions where given administration rights.

Busy Lamp Field (BLF) Indicators

Feature

- Status indicators which show the status of a programmable buttons associated feature or function.

Benefit





- Indication of when a button or associated feature is active.

Description

Avaya digital and IP phones have programmable buttons which can be assigned to various features. When those buttons include some form of BLF indicator, the button can also be used to indicate when the feature is active. For example, a button associated with another user will indicate when that user is active on a call. A button associated with a group will indicate when the group has calls waiting to be answered.

The directory entries in one-X Portal for IP Office and the speed dial icons within the IP Office Phone Manager and SoftConsole applications also act as BLF's. When the icons are associated with internal users, the icons will change to indicate the current status of the users.

one-X Portal for IP Office shows these conditions:

State	Icon	Description
Available		The normal state for a user showing that their work extension is not in use.
Busy		The normal state for a user showing that their work extension is currently on a call.
Do Not Disturb		The user has set Do Not Disturb. Calls to them will go to voicemail if enabled or else get busy tone unless you are in the user's Do Not Disturb exception list.
Logged Out		The user has logged out from their phone. Calls to them will most likely go to voicemail if available.
Other		This icon is used when the status is not known.

Call History

Feature

- Access to a list of called, received and missed calls from the phone and/or IP Office user productivity applications.

Description

IP Office keeps a record of calls made and received, including unanswered calls. Details are stored for both users (maximum 30 entries) and hunt groups (maximum 10 entries). The method of operation varies according to the phone type but in all cases the call records can be used for return calls.

With IP Office Release 6, a centralized call log is supported by 1400, 1600 and 9600 Series phones (not 1403 or 1603/1603SW) and one-X Portal for IP Office (leading to consistency between the two). 5400 Series and 5600 Series call logs are stored on the phone.

one-X Portal for IP Office accesses the centralized call log and therefore presents a record of all calls even if the user's PC is switched off when a call is received. Call log entries can be added to the personal directory..

IP Office Phone Manager maintains a call history record of the user's last 100 calls. The application must be running to record call history. Phone Manager Lite can display call history for all calls and missed calls only. Phone Manager Pro can display call histories for all calls, missed calls, inbound calls and outbound calls. Entries in the call history can be used for return calls, sorted and added to the Phone Managers local directory or speed dials.

Benefit

- Missed calls are easily tracked and can be returned.
- Call log data is retained even after power down and a system reset (1400, 1600, 9600, T3 and one-X Portal for IP Office).
- Centralized call log is supported in the SCN when using hotdesking (1400, 1600, 9600, T3 and one-X Portal for IP Office).
- Consistency between desktop phones and user productivity application (1400, 1600, 9600, T3 and one-X Portal for IP Office).

Language

Avaya digital and IP phone menus and displays are available in many languages and usually the system default setting will be applicable to all phones, however it is possible to have language set on an extension by extension basis, this will also change the language of menus for IP Office Voicemail.

Centralized Personal Directory

Feature

The IP Office Personal Directory is a list of up to 100 numbers and associated names stored centrally in the system for a specific user. A directory entry can be used to label an incoming call on a caller display telephone or on a PC application. The directory also gives a system wide list of frequently used numbers for speed dialing via one-X Portal for IP Office, Phone Manager or a feature phone with a suitable display.

For example "Mr Smith" can be displayed when a known Caller ID is received. A user can also select "Mr Smith" in the Directory List in Phone Manager, one-X Portal for IP Office or on a display phone to speed dial this number.

Description

- The personal directory capability allows up to 100 entries per telephony user.
- The system limit is:
 - 10800 for IP Office 500 and IP Office 500 V2.
 - 3600 for IP Office 412.
 - 1900 for IP Office 406 V2.
- All entries may be added, deleted or modified by Manager, one-X Portal for IP Office, a telephone, or an external service.
- The personal directory data is sent/updated whenever the user is logged in a SCN.

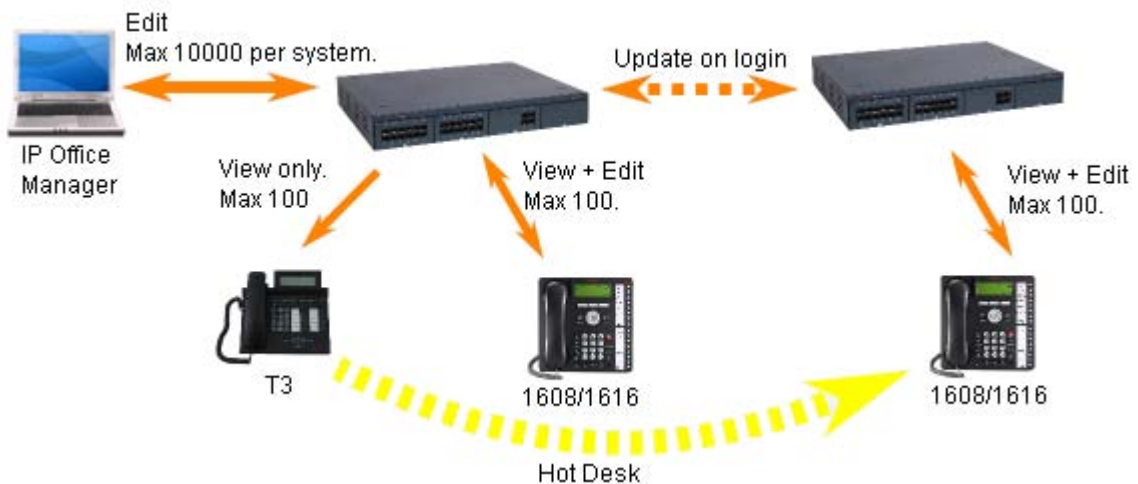

Benefit

- The user has a personal directory independent from the phone (1400, 1600, 9600 and T3 only) at which they are logged in
- The personal directory is always synchronized between telephone and one-X Portal for IP Office.

Centralized System Directory

Feature

The IP Office Directory is a list of up to 5000 numbers and associated names stored centrally in the system. A directory entry can be used to label an incoming call on a caller display telephone or on a PC application. The Centralized System Directory also gives a system wide list of frequently used numbers for speed dialing via one-X Portal for IP Office, Phone Manager or a feature phone with a suitable display.

For example "Head Office" can be displayed when a known Caller ID is received. A user can also select "Head Office" in one-X Portal for IP Office, or the Directory List in Phone Manager, or on the display phone Directory to speed dial this number.

Description

- External directory entries can be obtained from up to three different sources for each IP Office:
 - Locally stored in the IP Office configuration. Created and edited using IP Office Manager or by selected 1600, T3 or one-X Portal for IP Office users.
 - Temporary entries imported at regular intervals from an LDAP server.
 - Temporary entries imported at regular intervals by HTTP from another IP Office. This allows the directory entries on one IP Office to be shared by other IP Offices as a centralized system directory for an SCN.
- The total maximum number of entries is 5000 with entries in the IP Office configuration taking priority over temporary imported entries.

	Manager	LDAP	HTTP	Overall Maximum
IP406v2	2500	2500	2500	2500
IP412	2500	2500	2500	2500
IP500 IP500 V2	2500	5000	5000	5000

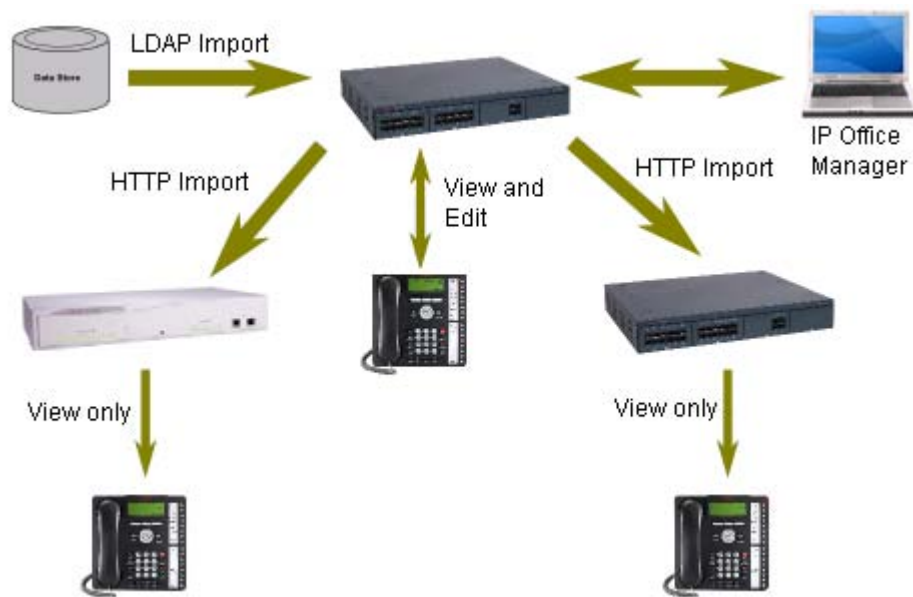

Benefit

- Ability to use external directory services with different interfaces
- One system directory for an SCN

Self-Administration

The IP Office administrator may give select users the ability to change some of the phone settings themselves. For example, button programming. The range of changes that the user can make depends on the phone type in use.

On Hook Dialing

Avaya digital and IP phones allow the user to make calls by just dialing the number on the keypad, without having to lift the handset or pressing a speaker button. Usually the call progress can be monitored using the speaker in the phone, on phones that support handsfree the whole conversation can be had without having to lift the handset.

In Release 6, this has been extended to allow "en bloc" dialing. This allows the whole number to be entered and then edited before it is actually dialed when going off hook.

Inbound Call Handling

IP Office offers several features to provide versatile inbound call processing, including PC based applications, and a standards-based TAPI interface for 3rd party applications.

Incoming Call Routing

Incoming calls can be presented to an Operator who then decides where to pass the call, but IP Office supports intelligent call routing capable of making routing decisions based on a number of criteria.

The system currently supports routing based on;

- Call presentation digits from the exchange such as DDI/DID or ISDN MSN.
- Calling telephone number or Caller ID (This could even be part of the number received such as an area code).
- ISDN sub-address.
- ISDN/PRI service type i.e. Voice Call, Data Call, etc.

It is even possible to look for multiple criteria so, for instance, a DDI/DID call to a sales group could be handled differently depending on which part of the country the call is originating from.

Each incoming Call Route also supports a secondary destination 'Night Service' that can provide alternative routing for an incoming call based on 'time of day' and 'day of week' criteria, as well as calendar-based routing for specific dates.

Calls that cannot be routed to the configured destination are re-routed to a user defined 'Fall Back' destination. This can be particularly useful where calls are normally answered by an auto-attendant and a network fault occurs.

Where multiple call routes are set up to the same destination, a Priority level can be associated with the call. This priority level is used to determine a call's queue position in place of simple arrival time, but note that calls already ringing a free extension are not considered queuing and are not affected by a high priority call joining a queue (unless the option "Assign Call On Agent Answer" is selected for that hunt group). A Priority Promotion Timer can be configured to increase the priority of calls which have been in the queue for more than a defined time.

An optional tag can be added to calls on the Incoming Call Route, which can be displayed on the alerting telephone.

Hunt Groups

A hunt group is a collection of users, typically users handling similar types of calls, e.g. a sales department. An incoming caller wishing to speak to Sales can ring one number but the call can be answered by any number of extensions that are members of the hunt group.

Four modes of call presentation are supported on IP Office;

- Sequential
One extension at a time sequentially always starting at the top of the list.
- Collective
All extensions in the hunt group simultaneously.
- Rotary
Start with the extension in the list immediately following the extension that answered the last hunt group call.
- Longest Waiting
Start with the extension that has been free for the longest time.

An option has been added, "Assign Call On Agent Alert", which means that CTI applications will always correctly report the details for the call that is alerting. The previous (default) behavior is now termed "Assign Call On Agent Answer" and ensures that the call at the head of the queue is always answered first.

If all extensions in the hunt group are busy or not answered, another hunt group, called an Overflow Group, can be used to take the calls. An overflow time can be set to stipulate how long a call will queue before being passed to the Overflow Group (this can be configured either for individual calls or for all calls in the group). The system can change the status of users who do not answer a hunt group call presented to them. The user can be put into busy wrap-up, busy not available or logged out. The change of status can be set per user and the use of this option can be set per hunt group.

Outside normal operation a hunt group can be put into two special modes; Night Service and Out of service.

In Night Service calls are presented to a Night Service Group. This can be controlled automatically by setting a time profile which defines the hours of operation of the main group or manually using a handset feature code.

Night service fallback using a time profile is no longer applied to a hunt group already set to Out of Service.

The Out of Service mode is controlled manually from a handset. While in this mode calls are presented to the Out of Service group

Voicemail can also be used in conjunction with hunt groups to take all group related messages, play an announcement when the hunt group is in Night Service or Out of Service mode and give announcements while a call is held in a queue. For internal voicemail use a broadcast option is provided. This feature will alter the voicemail box operation so that the message notification will only be turned off for each hunt group member when they retrieve their own copy of the message.

Small Community Networking (SCN) Distributed Hunt Groups

Small Community Networking (SCN) Distributed Hunt Groups

Hunt groups in a Small Community Network can include members located on other systems within the network.

Note: Distributed Hunt Groups are not supported for use with CCC or CCR.

Night Service

When a hunt group is in Night Service mode, the hunt group is temporarily disabled. Callers to this hunt group will:

- Pass to a Night Service Fallback group used to provide cover, e.g. pass calls to a manned extension or an external number
- Be played the Out of Hours greeting if voicemail is operational
- Receive the busy tone

A hunt group can be switched in or out of Night Service mode by a user dialing the appropriate short code – by any extension or by specific users.

Time Profiles

Time Profiles can be used to define when a Service, Hunt Group, Least Cost Route, Conference Bridge or a user's dial-in facility are operational. For example, a time profile can be used to route hunt group calls to a manned extension or voicemail outside of office hours, or be used to apply different Least Cost Routes at varying times of day to take advantage of cheaper call rates. Multiple Time Entries can be created so that a Time Profile can be used to define specific hours in the day e.g. 09:00-12:00 and 13:00-17:00. Outside of a Time Profile, voice calls would be re-routed according to the configuration but any currently connected calls at the time the Time Profile changes would not get cut off as the change only affects the routing. Data calls will get cut off as the time profile goes out of service but a new data call will start immediately if specified. From Release 4.1, Time Profiles can also be based on specific calendar dates to make allowance for public holidays or other events.

Queuing

Queuing allows calls to a hunt group to be held in a queue when all extensions in the group extension List are busy. When an extension becomes free the queued call is then presented. The definition of queued calls now includes ringing calls and calls waiting to be presented for ringing. The queue limit can be set to control the maximum number of calls to wait against a hunt group.

While queuing, if Voicemail is operational, the caller will be played the announcements for this hunt group.

Announcements

From IP Office 4.0 onwards, Hunt group announcements are separated from hunt group queuing and can be used even when queuing is off. Hunt group announcements are now supported by Embedded Voicemail in addition to VoiceMail Pro.

Further, times for the first announcement, second announcement, and between repeated announcements are configurable.

Contact Center Features

Contact Centers have specific needs for reporting on how calls are handled and these are covered in a separate section of the Product Description. Basic handling of telephony requirements for a Call Center is a standard part of IP Office from Automatic Call Distribution (ACD) and Call Queuing to agents logging on and selecting the groups that they service.

Login

A contact center agent function, login is required before the agent is able to make or receive calls from their phone. A login idle period can be specified which will dictate how long an extension can be idle before the user is automatically logged out, ensuring that an extension is not left logged in and calls go unanswered.

Monitor Calls

A user can monitor other peoples' calls by listening in. This feature is not available by default; it must be specifically enabled in the system configuration. An option exists to have a beep tone indicate when monitoring is in use. The user is only able to listen; they cannot speak into the conversation being monitored.

Acquire Call

Feature

- Takeover a call currently connected at another extension. This feature is also known as "Call Steal".

Benefit

- Assist a colleague who indicates they want you to take the call.

Description

The Acquire Call function can be setup as a special short code or programmed against a button on an Avaya digital or IP phone with programmable buttons. Use of the feature is subject to IP Office intrusion control settings, the user acquiring the call must be set to be able to intrude and the user whose call is being acquired must be set to can be intruded. Acquire call works in two ways, invoked with or without a number:

Without a value in the number field

- This allows a user to reclaim a call that was ringing on their phone but has now gone elsewhere, for example to Voicemail or Forward No Answer destination. The Intrude settings are not checked and the call can be reclaimed even if it has been answered.
- If the last call to ring this User is no longer ringing or connected on the system, the feature will fail.

With a number, where the number is the telephone number of a user who currently has the call to be acquired.

- If the user has a call ringing or waiting Acquire Call will act like the Call Pickup Extension short code and the user executing Acquire Call will be connected to the oldest ringing/waiting call.
- If the User has a connected call with no call waiting and the Intrude settings of the two Users allow it, the call will be connected to the user executing the Acquire Call and the other user will be disconnected.
- If the User does not have a call the feature will fail.

Queue Threshold Alert

When the number of calls queued against a hunt group exceed a threshold, the system can be configured to alert at a selected analog extension port. Typically the User to Alert will be a loud ringer or other alerting device. The alert does not present a real call.

Miscellaneous Features

Conference Calls

Calls can be placed on hold and a conference created using either the phone or desktop applications. Additional conference members may be added, however a single conference may not have more than 64 members.

For the IP500 and IP500 V2 the total conferencing capacity is 128 channels. This could be alternatively 2 conference of 64 users, 3 conferences of 42 users or any other combination (maximum 64 participants per conference call).

Only two calls connecting through analog trunks are permitted in any single conference.

For more information on managing conference calls, refer to the [Audio Conferencing chapter](#) ^[274].

Dial On Pickup

Also known as "Hotline". Automatically dials a specified extension when the phone is taken off hook. This facility is commonly used in unmanned reception areas or for door entry systems to allow visitors to easily gain assistance.

Off Hook Operation

Off-Hook Station is designed for users who want their analog phone to operate like digital or IP feature phone, to isolate the user's phone idle state from the Hook state. This is a useful feature when using one-X Portal for IP Office, Phone Manager or SoftConsole to control the phone state when using a headset on an analog telephone and with call control and dialing from one-X Portal for IP Office, Phone Manager or SoftConsole.

External Control Port

The IP Office system unit has two electronic switches, similar to relays, which can be normally open, normally closed, pulsed open or pulsed closed and activated by dialing a short code or through Phone Manager, SoftConsole or VoiceMail Pro action.

These switches can be used for several purposes, for example as a means to control an electronic door release. The External Control Port switches are used to trigger/control purpose built door release equipment which is supplied by a third party. All that needs to be done is to wire the trigger/control output of the third party device to the appropriate External Control port pins.

E911

This is a specific service for North America. When an emergency call is connected, IP Office provides calling party information to an external line interface unit. The external unit carries out a number to text translation and forwards this to the emergency services bureau so that the originating location of the call is clearly identified.

System Short Codes

Short Codes are used as commands the IP Office to make changes for the user, group or system, so need to set up with consideration to security. The command may need additional information included with it, such as for forward, the phone number forwarded to. Short codes are a flexible and quick way of setting up certain features. IP Office has short codes provided by default on the system, or more advanced codes that need programming by the system administrator.

The full set of short code commands are listed below; please see product configuration documents for more detail on how to set them up.

AOC Previous Call	Dial 3K1	Follow Me Here	Resume Call
AOC Reset Total	Dial 56K	Follow Me Here Cancel	Retrieve Call
AOC Total	Dial 64K	Follow Me To	Ring Back When Free
Auto Attendant	Dial CW	Forward Hunt Group Calls On	Secondary Dial Tone
Break Out	Dial Direct	Forward Hunt Group Calls Off	Set Absent Text
Busy	Dial Direct Hot Line	Forward Number	Set Account Code
Busy On Held	Dial Emergency	Forward On Busy Number	Set Authorization Code
Call Intrude	Dial Extn	Forward On Busy On	Set Hunt Group Night Service
Call List	Dial Inclusion	Forward On Busy Off	Set Hunt Group Out Of Service
Call Listen	Dial Paging	Forward On No Answer On	Set Inside Call Seq
Call Pickup Any	DialPhysicalExtensionByNumber	Forward On No Answer Off	Set No Answer Time
Call Pickup Extn	DialPhysicalNumberByID	Forward Unconditional On	Set Mobile Twinning Number
Call Pickup Line	Dial Speech	Forward Unconditional Off	Set Mobile Twinning On
Call Pickup Group	Dial V110	Group Listen Off	Set Mobile Twinning Off
Call Pickup Members	Dial V120	Group Listen On	Set Outside Call Seq
Call Pickup User	Dial Video	Headset Toggle	Set Ringback Seq
Call Queue	Disable ARS Form	Hold Call	Set Wrap Up Time
Call Record	Disable Internal Forwards	Hold CW	Shut Down Embedded Voicemail
Call Steal	Disable Internal Forward Unconditional	Hold Music	Startup Embedded Voicemail
Call Waiting On	Disable Internal Forward Busy or No Answer	Hunt Group Disable	Suspend Call
Call Waiting Off	Display Msg	Hunt Group Enable	Suspend CW
Call Waiting Suspend	Do Not Disturb Exception Add	Last Number Redial	Toggle Calls
Cancel All Forwarding	Do Not Disturb Exception Delete	MCID Activate	Unpark Call
Cancel Ring Back When Free	Do Not Disturb On	Mobile Twinned Call Pickup	Voicemail Collect
Channel Monitor	Do Not Disturb Off	Off Hook Station	Voicemail Node
Clear Call	Enable ARS Form	Park Call	Voicemail On
Clear CW	Enable Internal Forwards	Private Call	Voicemail Off
Clear Hunt Group Night Service	Enable Internal Forward Unconditional	Private Call Off	Voicemail Ringback On
Clear Hunt Group Out Of Service	Enable Internal Forward Busy or No Answer	Private Call On	Voicemail Ringback Off
Clear Quota	Extn Login	Priority Call	
Conference Add	Extn Logout	Record Message	
Conference Meet Me CW	Flash Hook	Relay On	
Dial		Relay Off	
		Relay Pulse	

Chapter 6.

IP Telephony

6. IP Telephony

Technological innovation is changing the way we communicate. This time it is coming in the form of changing the way telephone calls are transmitted. It brings with it several new capabilities that change the meaning of the phrase telephone call through the use of Voice over Internet Protocol (VoIP). Basically, VoIP means "voice transmitted over a packet data network." VoIP is often referred to as IP Telephony because it uses the IP protocols to make possible enhanced voice communications throughout the world, wherever IP connections have been delivered. IP Telephony unites a company's many locations- including mobile workers- into a single converged communications network. Telephony calls using VoIP go above and beyond what's been possible in the past. When it comes to placing telephone calls, VoIP provides a range of support services and features unequalled in the world of telephony, but above all deliver them at low cost.

How Does VoIP Work?

Voice over Internet Protocol means basically what the acronym states: Voice travels over an Internet Protocol. Internet Protocol refers to the type of rules that the network uses to send and receive signals. IP Telephony works by converting voice communications into data packets. Conveniently, it runs on the popular Ethernet LAN (local area network) technology, which currently supports over 96 percent of the worlds companies' LANs.

Circuit-switched or Time-Division Multiplexed Telephony

Before digital networking with the Internet took off, everyone had to use the "Plain Old Telephone Services" (POTS). These run over a network called the Public Switched Telephone Network (PSTN). The PSTN has been around since the telephone was invented in either analog or digital form using circuit switched technology where the telephone call gets exclusive bi-directional use of a wire – or circuit – while the call is in progress. Because the circuit is exclusive to each conversation, PSTN and private branch exchanges (PBXs) must be sized to cope with peak demand and have enough circuits available for all expected conversations. This is not a flexible approach and results in a lot of infrastructure investment that the telephone companies need to recoup, via the cost of access charges and calls. The Internet has changed this – where data services have driven down access charges and allowed voice to "travel for free" over a multipurpose data network.

Packet-Switched Telephony

Unlike circuit-switched connections, which always require use of dedicated bi-directional circuit for the duration of a call, VoIP technology has enabled telephony and other new and novel features and services to run over fixed and wireless networks including private local area networks. These newer network types use packet-switched protocols. Packet-switched VoIP puts voice signals into packets. Along with the voice signals, VoIP packets include both the sender's and receiver's network addresses. VoIP packets can traverse any VoIP-compatible network. Along the way, they can choose alternate, shared paths because the destination address is included in the packet. The routing of the packets is not dependent on any particular network route which means the network provides can provide a reliable service at a fraction of the cost of circuit switched providers.

What Advantage Does IP Office Have?

IP Office can provide support of PSTN, POTS, digital time division multiplexed phones AND digital IP phones all on the same system. This means you don't have to abandon the past to embrace the future, IP Office allows all the technologies to co-exist. IP Office connects to the PSTN and to IP trunks (the VoIP equivalent) so providing a "Hybrid" PBX function – where both legacy and future technologies can be used together to minimize operating costs and offer optimize business communications through both voice and data.

IP Office has digital telephones built on both TDM and IP technology that provide the same user interface offering a flexible choice of solution that can mix, for example TDM phones in the office and IP phones at a remote site or at home. With the choice of IP phones including real and virtual (software) phones, IP Office can take communications to a new level.

Buying IP Office allows you choice – you can use the pure POTS or the pure VoIP capabilities of IP Office, or use both at the same time to allow seamless technology transition of your business without the disruption of having to choose between them now.

IP Office Turns VoIP into IP Telephony

In order to make use of VoIP, IP Office uses signaling protocols called H.323 right now, and Session Initiation Protocol (SIP) which allow IP Office to establish end-to-end connections for the voice path through the IP network. It ensures each end of the connection is able to transmit and receive voice and provides the network addressing for end to end packet transmission. IP Office also allows for connecting between the different technologies by translating the signals they use, for example an analog phone may wish to connect to a VoIP destination. This requires both the signaling and voice transmission to be translated – IP Office does this easily as it contains technology elements called gateways and gatekeepers that enable translations to happen.

With a conventional telephone system you plug your analog or digital TDM telephone into an extension socket connected to your PBX or Key System. With IP Telephony you connect your digital IP telephone to your IP PBX via the LAN. There are two basic types of IP phones:

- A physical phone, which looks very similar to a standard telephone (IP Hard Phone)
- A software application (Phone Manager PC Softphone) which runs on the user's PC, allowing them to use either a headset/microphone to make/receive calls anywhere they have IP connection

IP telephony has the advantage of allowing extensions to be deployed both locally and remotely through the use of IP routing and IP VPN services.

When making use of IP telephony, there are a number of data centric considerations such as which data types have priority on the IP network when there is contention. This is set with IP/TCP "quality of service" and should not be ignored. In situations where LAN Bandwidth is limited, a quality of service capable LAN switch should be used to ensure voice packets are transmitted with the required priority on the network. If not, the conversation carried over IP appears as broken up (due to packet loss) or has unacceptable delays introduced in the conversation (latency and jitter). With IP hardphones there is need for Power over Ethernet (PoE) or "midspan power" to be provided to the phones as the IP phones are no longer powered by IP Office – a list of Avaya approved PoE options is available at the end of this section.

Gateways, Gatekeepers and H.323 - Technology Overview

IP Office uses the H.323 signaling protocol which has the following architectural components

- Telephones are H.323 service endpoint devices that can support Audio calls. Other types of H.323 devices can support video as part of H.323
- Gateways provide media translation to allow calls to be made to non-H.323 devices, for instance an analog telephone or the public network to connect with a H.323 device
- Gatekeepers control the call processing and security for H.323 devices
- Multipoint Connection Units (MCU) for conferences by adding together media streams

These elements are grouped together in what is known as an H.323 zone (a zone is analogous to a PABX). Each zone has a single Gatekeeper that can be considered as the brains of the system dealing with call distribution, call control and the management of resources. On power-up, IP telephones, Gateways and MCU make registration requests to a Gatekeeper which then authenticates (accepts or rejects) their request to become a member of the zone. Once accepted, a telephone wishing to make a call sends a call set-up message to the Gatekeeper which then determines how to route the call and will then send an alert to the called telephone, or if the call is to a non-H.323 telephone establish the call via a Gateway within the zone.

The design of IP Telephony systems has been driven by open standards. Digital IP Phones, Gateways and Gatekeepers all support the H.323 standard and it is this that allows devices from different manufacturers to work together. IP Office has an optional integral Gateway (Voice Compression Modules) and Gatekeeper functionality required to provide a fully functional IP Telephony solution.

IP Telephony Features

- **Gatekeeper**
The IP Office gatekeeper allows the registration of up to 190 IP extensions on the IP406, 360 IP extensions on the IP412 and 384 IP extensions on the IP500, less the number of analog and digital TDM telephones already configured on the system.
- **Gateway**
The Voice Compression Module provides the H.323 gateway function that allows IP extensions to make calls to other non-IP devices. The maximum number of simultaneous calls is limited by the number of channels available on the Voice Compression Module. IP Office must be fitted with an optional Voice Compression Module to enable IP telephony.
- **Silence Suppression**
Silence suppression is a technique used to make the best use of available bandwidth, such as the connection over which the caller is listening, not speaking. Silence suppression works by sending descriptions of the background noise, rather than the actual noise itself, during gaps in conversation thereby reducing the number and frequency of voice packets sent on the network. Background noise is very important during a telephone call. Without noise the call will feel very unnatural and give a perception of poor quality.
- **Compression**
IP Office supports a wide range of voice compression standards including G.711, G.729a and G.723.1. The method of compression can be either automatically established on a call-by-call basis or be configured on an individual extension basis.
- **Fast Start**
When fast start is supported by an IP extension, this facility reduces the protocol overhead allowing an audio path to be established more quickly.
- **Out of Band DTMF**
When out of Band DTMF is configured on an IP extension, the extension will signal to the other end of the connection which digits need to be regenerated by a local DTMF generator on behalf of the sending IP extension. This is useful when navigating external voicemail systems and Auto-Attendants.
- **Direct Media Path**
Direct Media Path allows the speech path between two IP extensions (after call setup) to be routed directly to each other. This allows the IP Office system to free up voice compression resources after establishing the end to end connection, allowing the resources to be used in the most efficient way.
- **Auto-Create Extensions**
IP Office can automatically create an extension entry for new IP phones added onto the local area network. In cases where the local area network is not secure this facility can be disabled, but simplifies installation of IP telephone systems
- **Fax Transport (Avaya Proprietary)**
Fax Transport allows fax calls to be routed over VoIP trunks between IP Office systems on an IP network using a proprietary IP Office transport protocol.
- **Fax Transport T.38**
IP Office supports the standardized protocol "T.38" for transporting FAX calls between IP Office and SIP trunks or SIP endpoints. T.38 is only supported on IP Office 500 hardware. It requires the IP Office to be equipped with VCM 32 or VCM 64 modules.

T.38 allows the reliable transmission of Fax messages over a IP channel independent of Codec used for the Voice communication.

Platforms Supported:	IP500 only, must be fitted with VCM32 or VCM64 module.
Trunk Types Supported:	SIP
Extensions Supported:	SIP
T.38 Transport Layers Supported:	UDPTL (with optional redundancy error correction).
T.38 Versions Supported:	0-3
Call Types Supported:	Voice calls which transition to fax relay on detection of fax tones. Calls which are negotiated as fax only

LAN Switch Support

Avaya recommend the use of Extreme switches for IP telephony applications. For more information, contact Extreme Networks.

SIP Endpoint Support

Session Initiation Protocol (SIP, pronounced just like sip, as in sipping from a fire hose on a hot day) is an open signaling protocol for establishing any kind of real-time communication session. The communication session can involve voice, video, or instant messaging, and can take place on one of many devices that people use for communicating: laptop computer, PDA, cell phone, IM client, IP phone, and so on. SIP has been developed in the *Internet Engineering Task Force (IETF)* by common participation from various vendors, including Avaya

Avaya IP Office supports SIP for telephony functions to enable the usage of standard based SIP endpoints for Voice and Fax communication. Different to pure SIP systems, IP Office expands the feature set beyond the SIP standard, offering a wealth of IP Office features also on SIP endpoints delivering a feature rich system that a pure-SIP server based on the SIP standard only can't deliver. With that, IP Office delivers the best of both worlds, supporting standard based IP telephones while delivering a wealth of features consistently between SIP, digital and Avaya IP endpoints.

IP Office SIP endpoint implementation is built on two major SIP components: SIP User agents, and SIP Server components.

SIP Components

SIP Endpoints (User Agents)

User agents (UAs) are applications in SIP endpoints (such as a SIP phone, cell phone, PDA, or workstation) that interface between the user and the SIP network.

SIP Servers

IP Office has implemented the required functionality of the SIP servers mentioned below not only to provide SIP endpoint support but also to allow full interoperability between SIP endpoints, other IP telephones based on H.323, Digital and Analog telephones as well as IP Office trunks (Analog, digital or SIP based)

SIP servers provide centralized information and enablement services in a SIP ecosystem. The core SIP servers and their functions are summarized here. IP Office provides the required features of the following two servers for Voice and FAX communication.

- **Registrar Server**
When SIP IP phones come online, they need to make sure that others are aware that they're available to take and make calls. The Registrar authenticates and registers the IP phone (often directly related to a specific user) when it comes online, and then stores information on the phones logical identities.
- **Proxy Server**
A proxy server takes SIP requests, processes them, and passes them downstream while sending responses upstream to other SIP servers or devices. A proxy server may act as both a server and a client, and can modify a SIP request before passing it along. A proxy is involved only in the setup and teardown of a communication session. After user agents establish a session, communications occur directly between the parties.

Functionality of the following two SIP servers are generally available by IP Office using existing IP Office functionality. Therefore, while functionality is provided, e.g. allowing hotdesking (also for users using a SIP-endpoint) in a small community network, a consistent methodology between SIP and non SIP endpoints is used to deliver those features

- **Location Service**
As users roam, the network needs to be continually aware of their locations. The location service is a database that keeps track of users and their locations. The location service gets its input from the registrar server and provides key information to the proxy and redirect servers. IP Office provides hotdesking support, delivering a similar functionality but working consistently between SIP and non SIP endpoints.
- **Redirect Server**
If users are not in their home domains, sessions bound for them needs to be redirected to them.

The redirect server maps a SIP request destined for a user to the device "closest" to the user. In IP Office, call forwarding and Follow me functionality is used to provide again consistent functionality between all type of endpoints.

Supported functionality for SIP endpoints in IP Office

Starting with IP Office R5, SIP endpoints are supported on IP Office for Voice (Audio) and Fax (T.38) communication.

This allows the usage of standard compliant IP telephones using the open SIP standard, giving customers a choice of endpoints of different manufacturers including special purpose devices like conference phones, hotel phones or terminal adapters.

In order to use a SIP endpoint with IP Office, a "Third party IP endpoint license" is needed. This license will continue to support endpoints based on the H.323 standard but will also be required for generic SIP endpoints on IP Office

SIP Endpoint support is fully integrated into IP Office core. No other components are needed. SIP endpoints will need VCM module capacity in IP Office like any other IP phone.

Next to SIP telephones, SIP terminal adapters are supported to connect analog phones and fax machines. This offers a flexibility to support Fax machines and Audio/T.38

SIP extensions function like any other IP Office extension: This means they

- Can make and receive calls to any other extension, independent of type of extension
- Delivers end to end Media just like any other IP telephone on IP Office. For calls between two SIP extensions of a SIP extension and a Avaya IP telephone, the audio is transmitted end to end for basic telephone calls. (Conferences etc. However require a VCM resource). See chapter "VCM modules" for details
- Can use short codes and authorization codes like any other phones
- Transmit In band call progress tones are delivered from IP Office
- A SIP phones needs to register with IP Office like any other IP telephone, Authentication with Username and password is possible
- SIP extensions support "auto create" in IP Office to make installation fast and efficient. Successful registration of a endpoint will consume one third party license
- On one IP address, several extension can register with IP Office, each consuming a license. This enables the connection of SIP terminal adapters with more than one analogue port, giving a different extension number to each of the ports.

Advanced features:

SIP endpoints support a number of extended features according to the "SIP service samples-draft", also referred to as "Sipping-19". This includes:

- Calling line identification
- Hold/Consultation Hold
- Attended/Unattended Transfer
- Message Waiting
- Do not disturb
- Conference Add

Some phones support several call appearances making it easy to switch between calls. Please note that this does not include "bridged appearances" or " (outside)-line appearances)

A large number of additional features are supported on IP Office using Feature activation keys. These features include but not limited to:

- Call forward: Unconditional/Busy/no Answer
- Follow me
- Park/Unpark
- Music on Hold
- Meet me conferencing
- Conference join
- Ring back when free

SIP endpoints also support Computer Telephony Integration "CTI" and therefore applications like One-X portal for Small business: the following features are supported with One-X portal and via the TAPI interface:

- Outgoing call (*without remote activation of speakerphone/headset*)
- Hang up
- Hold
- Attended/Unattended transfer
- Conference (*IP Office based*)
- Voicemail collect
- Set forwarding/DND (*IP Office based*)
- Park/Ride (*IP Office based*)

The features work similar like "CTI" features in combination with an analog telephone, e.g. a outgoing call will first ring the SIP phone and after connect the outgoing call will be placed. Avaya Phone Manager/ Phone Manager Pro and Soft console are currently not supported in combination with SIP-endpoints.

The SIP endpoint support implementation is compliant with the following standards or "RFCs".

- RFC 3261 - SIP session Initiation Protocol
- RFC 1889 – RTP
- RFC 1890 - RTP Audio
- RFC 4566 – SDP
- RFC 2833 - RTP /DTMF
- RFC 3264 - SDP Negotiation
- RFC 3265 - Event Notification
- RFC 3515 - SIP Refer
- RFC 3842 - Message Waiting
- RFC 3310 – Authentication
- RFC 2976 – INFO
- RFC 3323 - Privacy for SIP (PAI) and draft-ietf-sip-privacy-04 (RPID)

For codecs support please refer to chapter to [VoIP Standards Supported](#)^[17].

While great care has been taken to be compliant with SIP standards, no guarantee can be given that all devices claiming support of SIP will work flawlessly. The SIP standard is constantly evolving with new features and methods introduced. Also, while being standard compliant, not all devices implement all options of the standard, making it hard to almost impossible to predict if a device will work- Avaya will only confirm functionality of devices that we have tested and will publish a list of devices that have been tested including – if required – implementation details and software version used on that device.

As of time of writing, the following devices have been tested successfully with IP Office Release 5 for Audio and/or Fax transmission.

SIP Telephones:	<ul style="list-style-type: none"> • Polycom Soundpoint IP 320, IP 601 • Grandstream GXP 2000, GXP 2020
SIP clients on mobile cell phones:	<ul style="list-style-type: none"> • Nokia S60 v3 SIP client (e.g. Nokia E61i mobile cell phone)
SIP Analog Terminal Adapters	<ul style="list-style-type: none"> • Quick Edition A10 ATA • Patton single line M-ATA • Innovaphone IP22, IP24, IP28
SIP PC-based softphones:	<ul style="list-style-type: none"> • CounterPath eyebeam/xlite

A updated list will be provided in the IP Office knowledge base and on <http://support.avaya.com>.

Power Options for IP Telephones

Avaya supports the IEEE 802.3af, standard for Power over Ethernet (PoE) on its range of IP telephones. With Power over Ethernet, both power and data are carried over one CAT 5 Ethernet cable. Deploying IP telephones utilizing Power over Ethernet eliminates the need for local power supplies, AC adapters and cables, and allows power to be provided from the wiring closet/switch room where it can be easily connected to a UPS system.

There are several power options, in addition to IEEE Power over Ethernet, available to customers to power their Avaya IP telephones.

- **Avaya Individual Power Supply for 4600 and 5600 phones**
Avaya provides individual power supplies that can be used to power each IP phone which provides a single 48 volt output. The power supply can operate globally within a wide range of Alternating Current (AC) input voltages: 90 - 264 Volts Alternating Current (VAC), 47-63 Hz. This power supply has a green indicator (LED) that shows the unit has power to the PHONE socket on pins 7&8 of the CAT5 cable. This item is available in two different versions, with and without an internal battery for uninterrupted power to the phone.
- **Avaya individual Power Supply for 1600 Series phones**
The 1600 Series phones have a special power connector to allow the connection of a cost efficient power supply. These power supplies come in several versions for different countries and voltages.
- **Avaya Power over Ethernet adapter for the 1603 phone**
The 1603 phone does not support Power over Ethernet natively. A small adapter is needed. The adapter will fit completely in the stand of the phone, offering a cost efficient option of either using a power supply or a PoE adapter.

IP Telephone Power Consumption

Measured in Watts using an IEEE 802.3af power supply at 48V. This table shows the power consumption of the phones currently shipping. Older versions of phones might have a different power requirement.

Telephone	PoE Class	Power Consumption (Watts)		
		Conservation Mode	Typical	Worst Case
4602SW, 5602SW	2	4.1	N/A	5.0
4610SW, 5610SW	2	4.0	N/A	6.0
4621SW, 5621SW	2	4.9	N/A	6.45
4625SW	3	7.8	N/A	9.42
1603/1603SW	2	4.32	3.75	5.10
1608	2	4.66	3.76	5.69
1616	2	3.17	2.83	3.65
Gig Adapter	-	3.16	N/A	5.81

Avaya Individual Power Supply

Avaya provides individual power supplies that can be used to power each IP phone which provides a single 48 volt output. The power supply can operate globally within a wide range of Alternating Current (AC) input voltages: 90 - 264 Volts Alternating Current (VAC), 47-63 Hz. This power supply has a green indicator (LED) that shows the unit has power to the PHONE socket on pins 7&8 of the CAT5 cable.

This item is available in two different versions, with and without an internal battery for uninterrupted power to the phone.



1151 local power supply, without battery and with battery backup

For 1600 Series phones, a separate line of cost efficient power supplies is available in different regional versions.

Avaya Mid-Span Power Distribution Units

These power devices are designed for IP-telephony and provide power over Ethernet (PoE) for up to 24 IP telephones or wireless LAN (WLAN) access points in one unit. The Mid Span Power units are designed to mount in a 19-inch rack with the data equipment or they can be stacked up to four units high using the optional rubber feet. The mid-span is 1U in height (1.75 inches) and has up to twenty-four RJ45 sockets on the bottom row and twenty-four data and power output RJ45 sockets on the top row. The units provide a maximum of 200 Watts or a peak of 16.8 watts per port. Data is unaffected by power delivery, if the device does not require power. The mid-span power units are also referred to as PDU (Powered Data Unit) devices. Power over the LAN will simplify the installation and support of IP telephones for our customers and are available in 3 sizes; 6, 12 or 24 ports with optional SNMP management capability.



Mid-Span power supply

VoIP FAQ

Network Requirements

Quality of Service (QoS) is a measure of the performance of a network that reflects the availability of network service and the quality of network transmissions. The term itself refers to a number of networking technologies and techniques and does not necessarily restrict itself to any single protocol or standard.

There are a number of measures that can be taken on the LAN and WAN to make them 'good enough' to carry voice traffic. Some of these are the implementation of standards based QoS protocols while are simply a matter of network architecture and good network management practices.

The term 'good enough' is intentional. Every customer will have different expectations and different budgets to work to. Some will be willing to upgrade their networks to use the best possible equipment and practices. To others the additional expense may be viewed as unnecessary.

Examples of standards based Quality of Service protocols include DiffServ and 802.1p/q.

What are Voice Compression Modules (VCM's) for?

VCM's are required to support the following scenarios:

- Internal phone calls between an IP device and a non-IP device.
- Analog/digital phones to IP trunks (SIP/H.323) including managed Frame Relay and managed IP VPN (provides echo cancellation).
- IP phones to ISDN or PSTN trunks (convert IP to TDM and vice-versa).

IP device to IP device

Call progress tones (for example dial tone, secondary dial tone, etc) do not require voice compression channels with the following exceptions:

- Short code confirmation, ARS camp on and account code entry tones require a voice compression channel.
- Devices using G.723 require a voice compression channel for all tones except call waiting.

When a call is connected:

- If the IP devices use the same audio codec no voice compression channel is used.
- If the devices use differing audio codecs, a voice compression channel is required for each.

"Direct Media" is a VoIP concept that circumvents resources (TDM bus, Gateway) within the system and improves the voice quality. If two IP devices are connected on the same system, a direct LAN connection between them will be established once the call has been set up (as long as they use the same Codecs). Direct media is supported between Avaya IP phones and SIP phones.

It is possible for an IP device to be physically located at one site while being registered at a different site. In this case, even for VoIP across the WAN the VCM would not be used, as long as the two IP devices involved in a phone call are registered on the same system.

Data Channels

A Data Channel is only required for Remote Access (RAS), Internet Access, and Voicemail connections:

- 10 PCs accessing the Internet over a single line = 1 Data Channel. If multiple lines are used (Multi-Link PPP) then as many data channels are required (e.g. 128k i.e. 2B channels requires 2 data channels)
- 10 users dialing in from home on 10 separate lines onto the LAN = 10 Data Channels
- Voicemail is an IP application on the LAN (i.e. one data channel is required for each voicemail port used)

Note: IP end-points do NOT require data channels

Bandwidth Required For Each Voice Call?

The bandwidth used varies depending on the compression method chosen. IP Office supports a wide range of compression standards, including the most popular G.723.1 and G.729a. These will occupy approximately 10K and 13K of bandwidth respectively.

Use the following chart to choose the most appropriate compression algorithm for your available bandwidth.

Audio Codec	RTP Voice Data Payload	Packets per Second	LAN (bps)	% Overhead LAN	WAN (bps)	% Overhead WAN	Algorithmic Delay (milliseconds)
G.723.1 (6.3K)	24 Bytes	33.33	20,800	225%	9,867	54%	80
G.729a	20 Bytes	50	29,600	270%	13,200	65%	40
G.711 (64K)	160 Bytes	50	85,600	34%	69,200	8%	20

Acceptable Delay?

End-to-end delay should be 150 milliseconds or below.

How Many Simultaneous Calls Can I Get Down My Link?

The following chart illustrates the theoretical maximum number of simultaneous voice calls that can be delivered over a WAN for a given link speed. This does not take into account any bandwidth that may be required for data traffic between sites or the physical limit of VoIP calls for the specific version of IP Office in use.

The number of simultaneous voice calls can be in excess of the capabilities of the individual platform, where the calls transit the switch as data traffic. In this situation compression resources are not used but obviously must be catered for in the overall bandwidth provision.

Compression	G.723.1 (6.3K)	G.729a (8K)	G.711 (64K)
Algorithmic Delay (seconds)	0.08	0.04	0.02
Number of Calls			
- 64Kbps Link	6	4	0
- 128Kbps Link	12	9	1
- 256Kbps Link	25	19	3
- 512Kbps Link	51	38	7
- 1Mbps Link	103	77	14
- 2Mbps Link	207	155	29

What is the Maximum Number of Simultaneous VoIP Calls

Each IP Office can be fitted with an optional Voice Compression Module (VCM) to support VoIP connections.

- The IP406 can be fitted with a single module offering up to 30 simultaneous calls.
- The IP412 is capable of supporting two modules of all types, allowing up to 60 simultaneous calls.
- The IP500 is capable of supporting two VCM 32/64 modules allowing up to 128 simultaneous calls.

Does the IP Office support Fax over IP ?

The IP Office supports a proprietary method for carrying Fax calls over IP between IP Office systems. It also supports T.38 on SIP trunks and SIP extensions.

Network Assessment

With IP Office, optimum network configurations can support VoIP with a perceived voice quality equivalent to that of the Public Switched Telephone Network (PSTN). However, not every network is able to take advantage of VoIP transmissions. It is important to distinguish between basic compliance with the minimal VoIP standards and validated support for QoS which is needed to run VoIP applications over a data network.

With the exception of standalone configurations where IP phones connect directly connected to the ports on IP Office, Avaya now requires that all customers formally audit their networks for IP telephony readiness before attempting to install any VoIP application.

A network assessment should normally include:

- Physical inventory of all equipment inclusive of the current version of code, and configurations as needed.
- An accurate and complete network topology for all networked sites, inclusive of IP addressing and physical/logical connections.
- An evaluation of the network's topology to check that the design is both sound and reasonable.
- Measurement of packet loss, jitter and delay over the course of multiple days and measured on a per minute basis. A graphical representation of the data is the preferred output method.
- Examination of QoS/Class of Service (CoS) parameters in place in the network.
- Summary of findings and possible actions to correct problems.

The assessment should leave you confident that the implemented network will have the capacity for the foreseen data and voice traffic, and can support H.323, DHCP, TFTP, and jitter buffers in H.323 applications.

With this in mind, if you require support during or after an IP Office VoIP installation, a copy of your network assessment documentation will be requested by your support channel.

For more details about available tools, resources and services to enable you to audit your network for VoIP readiness, please contact your local Avaya representative.

IP Packet Flow Control

While a high-performance switch forwards data packets at full wire speed to and from its ports simultaneously, there may be times when a switch port may not be able to accept packets at the rate it is receiving them.

For example, the switch port may be receiving packets from multiple ports at the same time, or the switch port may be receiving packets from a port operating at a faster speed. For instance, the sending port might be operating at 100 Mbps, while the receiving port operates at 10 Mbps; or the sending port might operate at 1000 Mbps, while the receiving port operates at 100 or 10 Mbps. If data packets arrive for a port that is saturated with other packets, the packets may overflow the port's buffer, resulting in dropped packets and lost data.

Flow control is a congestion-control mechanism that prevents data loss at congested ports. Flow control prevents packet loss by controlling the flow of data from the transmitting device to ensure that the receiving device can handle all of the incoming data.

IEEE 802.3 flow control is used on Avaya IP telephones operating in full-duplex mode. If the receiving device becomes congested, it sends a pause frame to the transmitting device. The pause frame instructs the transmitting device to stop sending packets for a specific period of time. The transmitting device waits the requested time before sending more data.

VoIP Standards Supported

IP Office supports the following protocols and standards:

- H.323 V2 (1998), Packet-based multimedia communications systems.
- Q.931, ISDN user-network interface layer 3 specification for basic call control.
- H.225.0 (1998), Call signaling protocols and media stream packetization for packet-based multimedia communication systems.
- H.245 (1998), Control protocol for multimedia communication.
- Session Initiation Protocol.
- Audio CODECs:
 - G.711 A-law/U-law (64K).
 - G.723.1 MP-MLQ (6.3K).
 - G.729 Annex A, Annex B, Annex AB – CS-ACELP.
- Silence Suppression.
- Fax Relay (IP Office to IP Office Fax Transport over IP).
- T.38 Fax support (SIP trunks and SIP endpoints).
- Local End Echo Cancellation 25ms.
- Out of band DTMF.
- Jitter buffer, 5 frames of jitter buffer.
- Internet Standards/Specification (in addition to TCP/UDP/IP).
 - RFC 1889 – RTP/RTCP, Real Time and Real Time Control Protocol.
 - RFC 2507, 2508, 2509 – Header Compression.
 - RFC 2474 – DiffServ, Type of Service field configurable.
 - RFC 1990 - PPP Fragmentation.
 - RFC 1490 - Encapsulation for Frame Relay.
 - RFC 2686 - Multiclass Extensions to Multilink PPP.
 - RFC 3261 - Session Initiation Protocol (SIP).
 - RFC 3489 - STUN.

Chapter 7.

Public and Private Voice

Networks

7. Public and Private Voice Networks

With Avaya IP Office you can be networked via T1, PRI and BRI ISDN, including VoIP on the company WAN. Networking maximizes the current potential of your branch maximizes the current potential of your branch office and remote workers- while building the office and remote workers- while building the best possible foundation for your future growth. IP Office provides each location with a scalable (up to 384 extensions) telephony solution that supports voice networking, and offers:

- A uniform dialing plan, making it easy to call co-workers anywhere on the network and improve customer service
- Consistent user experience by sharing the same phones and messaging interface as in headquarters
- A user-defined central directory that is automatically synchronized
- Least cost routing and bandwidth on demand
- Centralized voicemail and/or the ability to network voicemail systems together

The benefits of networking:

- Operate a network of branch offices with a consistent set of communications and services across all locations; gain the efficiencies of universal functions and end-user familiarity.
- Leverage any existing investment in Avaya systems at other sites
- Centralize services (e.g. operator, voicemail) as well as management and administration to reduce costs
- Speed deployment of remote offices- respond more quickly to market demands.
- Improve inter-site communication to simplify information exchange and enhance customer service.

Private Circuit Switched Voice Networking

Private voice networks are built using structured leased line circuits (E1 or T1) or by establishing permanently connected 'B' channels over ISDN circuits between IP Office systems. Each channel within the E1 or T1 interface can provide a single voice or 64K/56K data call. Where leased line circuits are used within a private networking scenario, these E1 or T1 interfaces are typically configured to use QSIG signaling between sites.

QSIG provides a level of voice feature transparency between PBXs and is the favored signaling standard within multiple vendor and international voice networks. The IP Office E1 or T1 module terminates a QSIG connection with a 120 ohm RJ45 interface.

IP Office supports the following QSIG services across this network:

- Simple Telephony Call/Basic Call: ETS300 171/172.
- Circuit Switched Data Call/Basic Call: ETS300 171/172.
- Called/Calling Line ID Presentation: ETS300 173.
- Called/Calling Name Presentation: (SS-CNIP, SS-CONP, SS-CNIR) ETS300 237/238.
- Message Waiting: (SS-MWI) EN301 260/255.
- Transfer: (SS-CT) ETS 300 260/261.

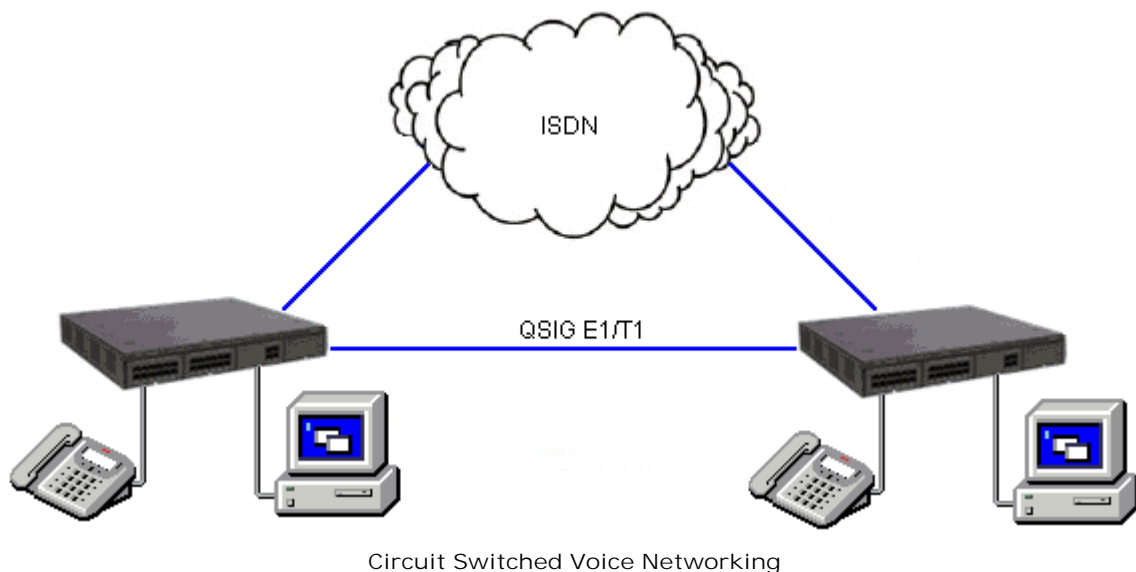

Public Voice Networking

The IP Office platform supports a range of trunks and signaling modes for connection to the public switched telephone network (Central Office). Some of these lines are only available in certain territories; please check with your distributor for local availability. Primary rate trunks are available with either a single (24/30 channels) or dual trunk (48/60 channels).

ISDN Primary Rate (ETSI CTR4)

Provided by the IP400 PRI E1 and IP500 Universal PRI cards.

ISDN Primary Rate provides 30 x 64K PCM speech channels over an E1 circuit and one signaling channel. Signaling Conforms to the ETSI Q.931 standard with Cyclic Redundancy error Checking (CRC).

The following supplementary services are supported:

- Calling Line Identification Presentation (CLIP) provides the telephone number of the incoming call to the IP Office.
- Calling Line Identification Restriction (CLIR) prevents the telephone number of the IP Office being presented on an outbound call.
- Connected Line Identification Restriction (COLR) Inhibits the COLP service.
- Direct Dialing In (DDI) where the exchange provides the last x digits of the dialed number on an incoming call. This allows IP Office to route the call to different users or services.
- Sub-addressing Allows the transmission/reception of up to 20 digits, additional to any DDI/DID or CLIP information, for call routing and identification purposes.

ISDN Basic Rate (ETSI CTR3)

Provided by the IP400 Quad BRI and IP500 BRI cards.

ISDN Basic rate provides 2 x 64K PCM speech channels and one signaling channel using Q.931 signaling and CRC error checking. Both point to point and point to multipoint operation is supported. Multipoint lines allow multiple devices to share the same line; however point-to-point is the preferred mode.

Basic rate supports all the services that are supported on the primary rate version with the addition of

- Multiple Subscriber Number. This service is usually mutually exclusive with the DDI/DID service and provides up to 10 numbers for routing purposes, very similar to DDI/DID.

Additional ISDN features

The following ISDN features are supported by IP Office 4.0+ on both PRI and BRI trunks. Note that availability of these features is dependant on their also being supported and available from the ISDN service provider, for which there may be charges.

- Malicious Call Identification – MCID
(24xx, 46xx, 54xx, 56xx, T3, T3 IP, DECT phones; Phone Manager)
Short codes and button programming features are available so that users can trigger this activity at the ISDN exchange when required. This feature is NOT available on standard ISDN DSS1 phones.
- Advice of Charge – AOC
(T3 digital and IP phones only; Phone Manager)
Advice of charge during a call (AOC-D) and at the end of a call (AOC-E) is supported for outgoing ISDN calls other than QSIG. The call cost is displayable on T3 phones as well as Phone Manager and included in the IP Office Delta Server SMDR output for call accounting purposes. The IP Office allows configuration of call cost currency and a call cost mark-up for each user.
- Call Completion to Busy Subscriber – CCBS
(2400, 4600, 5400, 5600, T3, T3 IP, DECT phones; Phone Manager)
CCBS can be used where provided by the ISDN service provider. It allows a callback to be set on external ISDN calls that return busy. It can also be used by incoming ISDN calls to a busy user. This feature is NOT available on standard ISDN DSS1 phones.
- Partial Rerouting – PR
(2400, 4600, 5400, 5600, T3, T3 IP, DECT phones; Phone Manager)
When forwarding a call on an ISDN channel to an external number using another ISDN channel, partial rerouting informs the ISDN exchange to perform the forward, thus freeing the channels to the IP Office. This feature is NOT available on standard ISDN DSS1 phones and it is NOT supported on QSIG.
- Explicit Call Transfer – ECT
(The normal usage of this feature is by a third party application)
ECT is supported on the S0 interface. A Call to an S0 Endpoint can be transferred to any other device such as an analog, digital or IP endpoint or to any trunk. The normal usage of this feature is by a third party application connected via one or more S0 interfaces to IP Office. One example is the VoiceDirector, an automatic call assistant.

North American T1

Provided by the IP400 PRI T1 and IP500 Universal PRI cards.

T1 Primary Rate provides up to 24 64K channels over a 1.54M circuit. Each channel of the T1 trunk can be independently configured (channelized) to support the following signaling emulations with handshake types of immediate, delay or wink.

- Loop-Start
- Ground-Start
- E&M Tie Line
- E&M DID
- E&M Switched 56K
- DID - Channels configured for DID/DDI support incoming calls only. The carrier or Central Office will provide the last x digits that were dialed to be used for call routing.
- Wink-Start

IP Office T1 trunks support both DNIS and ANI services, where available from the central office.

- Dialed Number Identification String (DNIS) Provides a string of digits to the IP Office depending on the number dialed by the incoming caller. This string can then be used to route callers to individual extensions, groups or services.
- Automatic Number Identification (ANI) Provides IP Office with a number identifying who the caller is. This may then be used for routing or computer telephony applications.

T1 trunk cards incorporate an integral CSU/DSU, eliminating the need for an external unit. The CSU function allows the trunk to be put in loop-back mode for testing purposes. This can be set manually, using the monitor application, or automatically from a Central Office sending a Line Loop Back (LLB) pattern. The DSU function allows the T1 trunk to be shared between data and voice services.

North American Primary Rate Interface

Provided by the IP400 PRI T1 and IP500 Universal PRI cards.

IP Office supports Primary Rate ISDN trunks on 5ESS or DMS100 central office switches provided by AT&T, Sprint, WorldCom and other Local Telcos. Channels can be pre-configured for the supported services or negotiated on a call-by-call basis.

Special Services can be configured to route calls to local operators or pre-subscribed carriers for both national and international calls (SSS). Alternate carriers can also be selected through the configuration of IP Offices Transit Network Selection (TNS) tables.

IP Office also supports the Calling Name and Number service over Primary Rate Trunks (NI2).

Analog Trunks

- **Loop Start**
Loop start trunks are available on the IP Office Analog Trunk cards installed within the IP Office control unit, or on the Analog Trunk 16-port expansion modules (ATM16). The first two trunks on the ATM16 are automatically switched to power fail sockets in the event of power being interrupted. They conform to the TIA/EIA-646-B standard. The loop start trunks also support incoming caller line identification (ICLID) conforming to GR-188-CORE and GR-31-CORE standards. IP Office can use this information to route calls or provide it to computer applications to display additional information about the caller.
- **Ground Start**
Ground Start trunks are only available on the ATM16, configured through IP Office Manager. The first two trunks on the module are automatically switched to power fail socket in the event of power being interrupted. They conform to ANSI T1.401 and TIA/EIA-646-B standards. Not available in all territories.

E1R2 Channel Associated Signaling

Provided by the IP400 PRI E1R2 and IP500 Universal PRI cards.

The IP400 PRI E1R2 cards are available in two versions supporting either RJ45 or coax network connections. Each card provides channels that can be configured for MFC, Pulse or DTMF dialing dependent on the requirements of the network.

Session Initiation Protocol (SIP)

IP Office supports SIP trunking. SIP trunks allow IP Office users to take advantage of new telephony services being offered by 'Internet Telephony Service Providers (ITSPs)'. In many cases, these telephony services can offer substantial savings in comparison to traditional exchange lines. The IP Office solution allows all users, regardless of their phone type, to make and receive SIP calls. SIP trunks are handled like any other line on IP Office, affording all the call routing and toll control needed to manage inbound and outbound calls.

SIP trunks on IP Office require the provisioning of voice compression channels through the installation of VCM modules within the control unit. RTP Relay is also supported to allow the IP stream through SIP after call setup. A license for the maximum required number of simultaneous SIP calls is also needed. Up to 128 simultaneous calls are supported.

IP Office also supports the T38 protocol which allows Fax over IP.

There are several possible network topologies for SIP trunk systems, as shown in the following diagrams.

Option 1: Service provider with a Session Border Controller (SBC), which solves NAT traversal issues – this is the most reliable and preferred method.

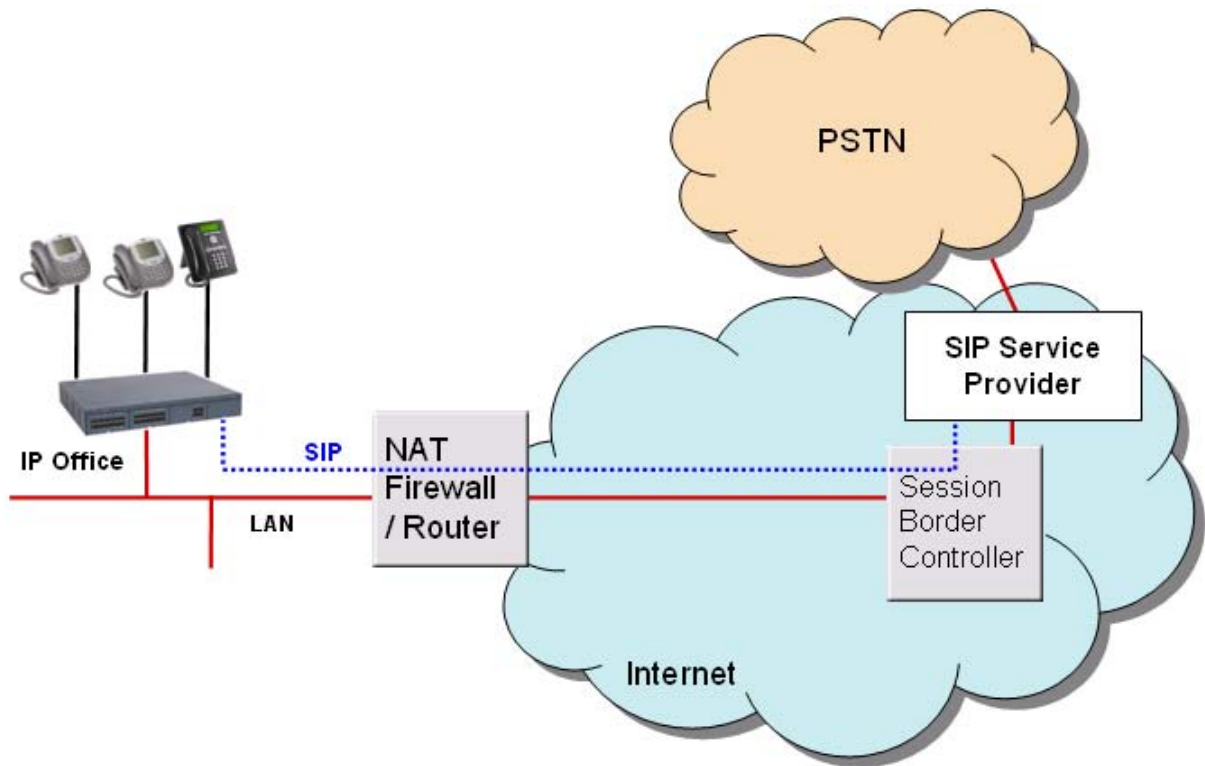

Option 2: Direct connection from the IP Office's second Ethernet port to the internet via a DMZ (demilitarized zone) port on the router. To make this configuration secure, the IP Office firewall is set to drop all packets except SIP.

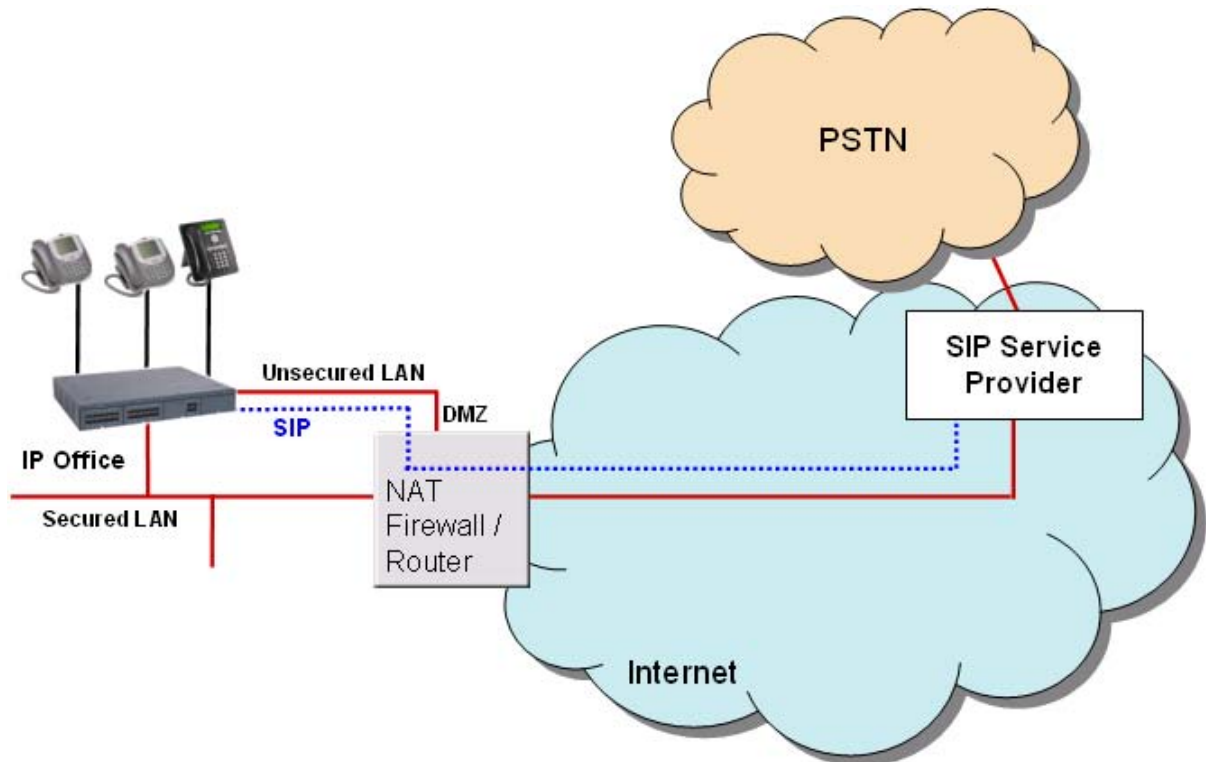

Option 3: Connection to the ITSP over NAT using 3rd party STUN (Simple Traversal of UDP through NAT) servers in the network to discover the NAT mechanism being used.

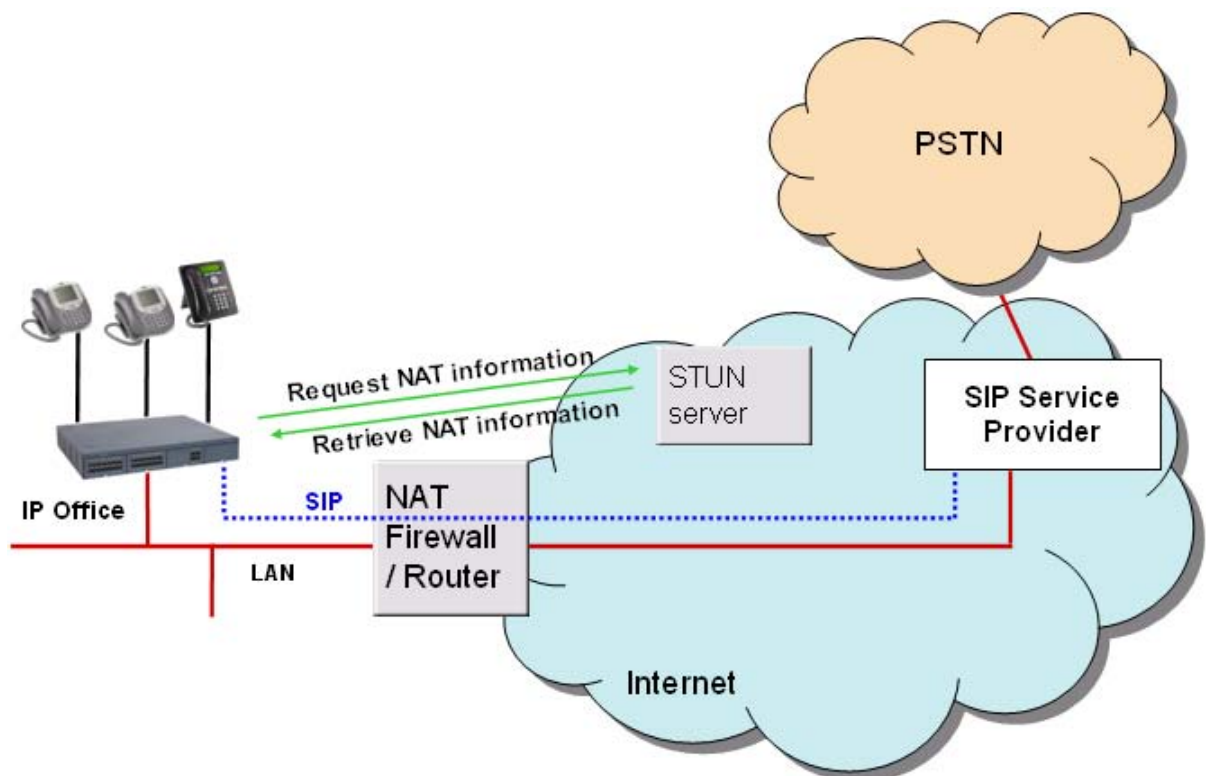

Option 4: Connection to the ITSP through a router equipped with an Application Level Gateway (ALG) which transparently resolves all NAT issues.

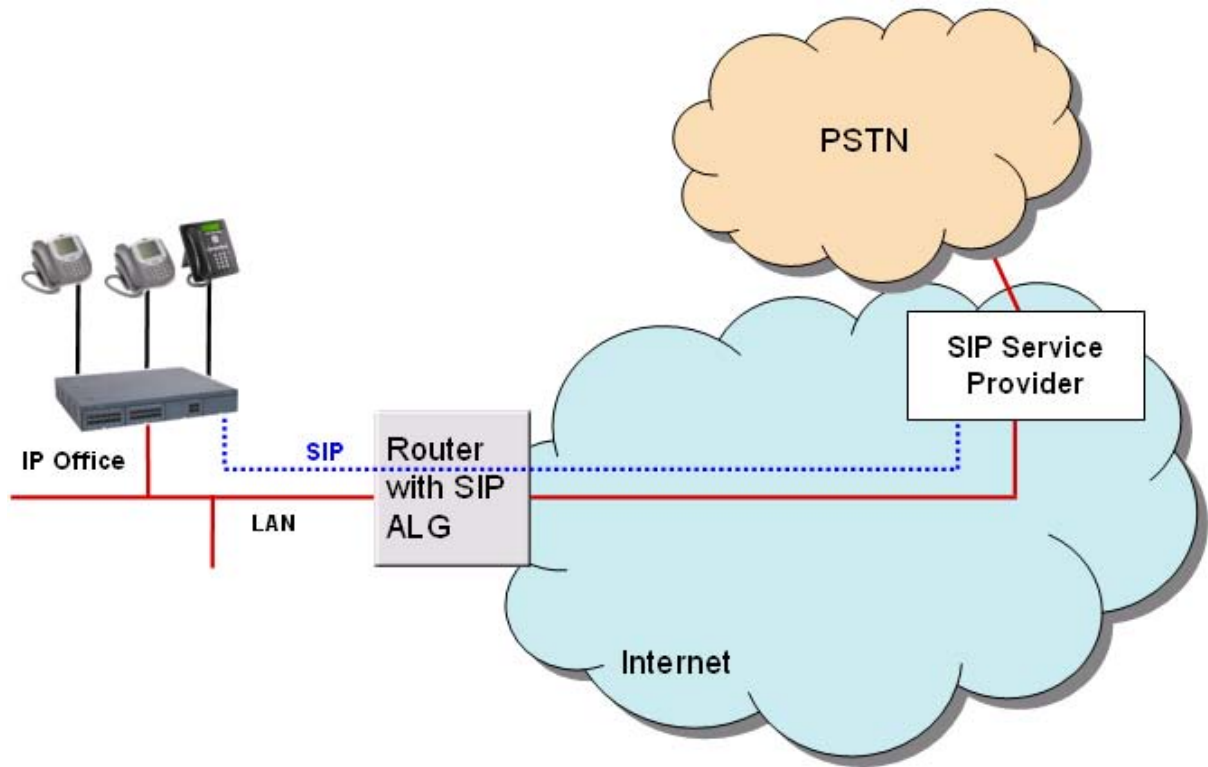

For details on SIP ITSPs which have been tested by Avaya, please see the Technical Bulletin for the IP Office 4.0 release and/or IP Office Knowledge Base at <http://www.avaya.com/ipoffice/knowledgebase>.

Packet Based Voice Networking

This section describes the options available for businesses that are able to utilize data networks to support voice solutions such as Voice over IP (VoIP). IP Office offers networked voice and data communications, providing:

- Built-in IP router
- One link for voice and data networking
- Common access to the Internet; share files and send e-mails to other sites
- Support for RIP-2 protocol for dynamic data routing; IPSec VPN, firewall and NAT (Network Address Translation) and for security; Centralized management and proactive fault management via SNMP.

IP Packet based voice networking between IP Office sites can be achieved through:

- VoIP across the campus LAN
- or VoIP across the public network.

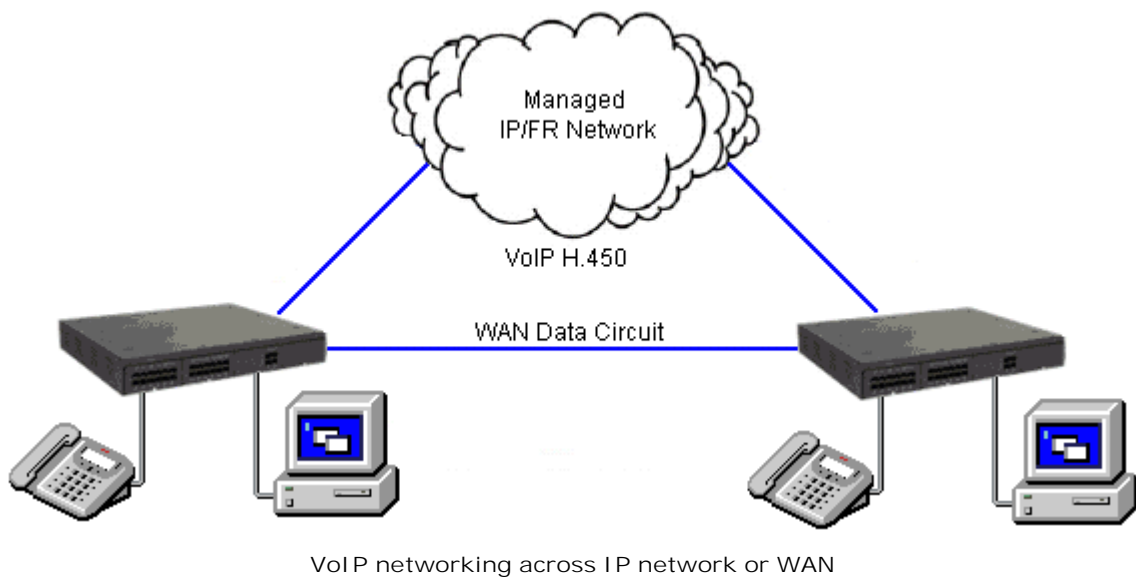

VoIP across the LAN

In a factory or campus environment, voice calls can be sent over 10/100 Mbps LAN connections on systems equipped with optional Voice Compression Modules (VCM). In order to avoid bandwidth contention issues, VoIP across the LAN will require some form of bandwidth management through Diffserve.

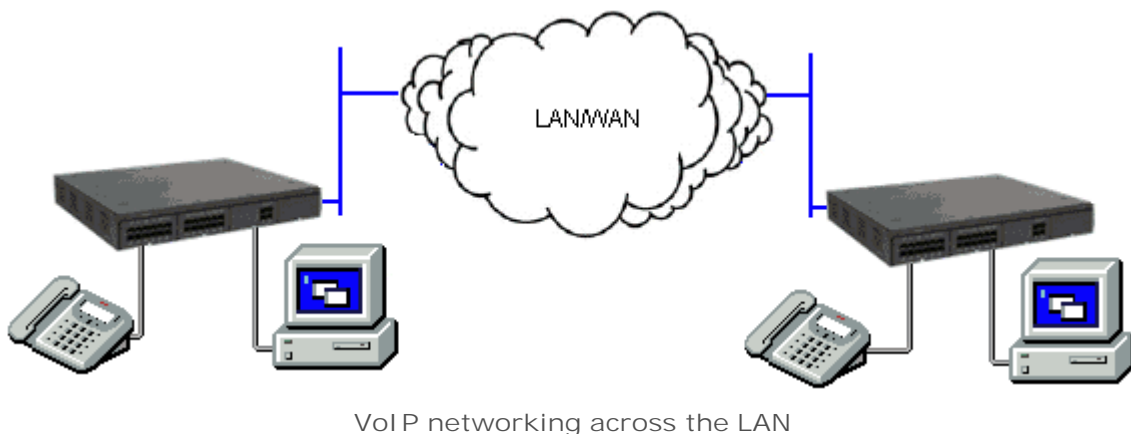

VoIP across the Public Network

IP Office is capable of realizing the benefits of G.931 and H.450 supplementary service support across a public connection where an appropriate QoS connection can be established.

Supplementary Services within IP Networks

Supplementary services within an IP environment are provided via Q.931 and H.323. IP Office provides the same rich services as enjoyed within a traditional network environment. Our standards based approach allows interoperability within mixed vendor networks.

The basic supplementary service features supported by H.323 on IP Office to IP Office IP trunk links are listed below.

- Basic call set up (voice).
- Call Hold (local).
- Call Transfer (local).
- Called/Calling Name.
- Called/Calling Number.

Additional features can be added through the use of IP Office Small Community Networking (see the following section).

On IP trunks to non-IP Office systems the Supplementary Service will depend on those also supported by the non-IP Office system.

Small Community Networking

When connecting IP Offices together over IP or Packet based networks, Small Community Networking enhances feature transparency. These networks can support up to a maximum of 1000 users across 32 sites. The following additional features are available.

- Busy Lamp Field
- Camp-on
- Call Back When Free
- Paging
- Call Pick-up
- Centralized Personal Directory for 1400, 1600, 9600 and T3 Telephones as well as one-X Portal for IP Office
- Centralized System Directory for 1400, 1600, 9600 and T3 Telephones as well as one-X Portal for IP Office
- Centralized Call Log for 1400, 1600, 9600 and T3 Telephones as well as one-X Portal for IP Office
- Centralized Voice Mail (Preferred Edition)
Support for mailboxes, call recording, dial by name and auto attendants. Remote queuing on remote systems is also supported.
- Internal Directory
- Absence Text Message
- Anti-Tromboning.
- Distributed Hunt Groups
Hunt groups can include users located on other IP Office systems within the network. Note that Distributed Hunt Groups are not supported for use with CCC and CCR
- Remote Hot Desking
Users can hot desk between IP Office systems within the network. The system on which the user configured is termed their 'home' IP Office; all other systems are 'remote' IP Offices. Note that Remote Hot Desking is not supported for use with CCC and CCR
- Breakout Dialing
This feature allows the user to select an IP Office system in the network from a displayed list and then dial a subsequent number as if dialing locally on the chosen system. This feature is triggered either by a programmable button or short code.

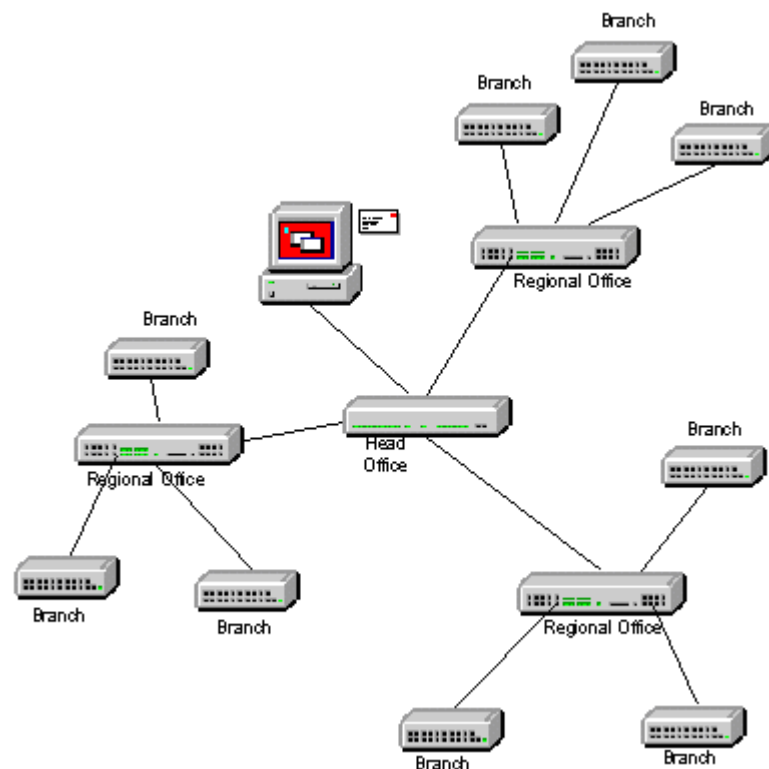

- Resilient SCN (see the diagram below)

In an SCN configuration of System "A" and System "B" where the centralized voicemail is connected to System B, and a number of IP phones are connected to either System A or System B. If System "B" fails then:

- System A will automatically take over from System B and support Avaya IP phones, hunt groups, and DHCP if required
- VoiceMail Pro will reregister to System A
- All System B users will have the use of their UMS and Mobility licenses on System A (no other licenses will be available)
- All System B users' Personal contacts/Call Logs will continue to be available (1600 Telephones)

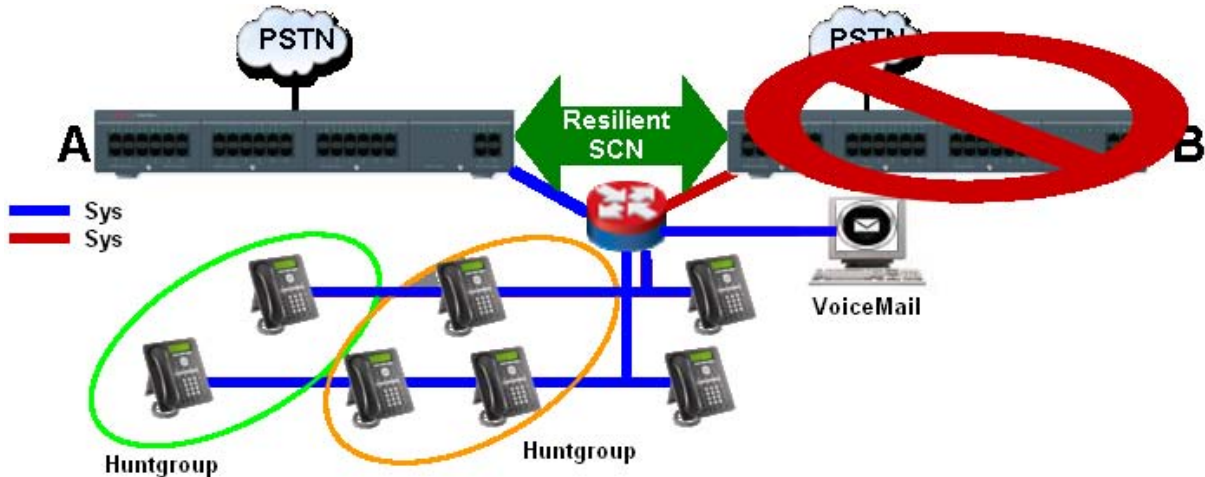

For Small Community Networks VCM modules are required in all systems being connected. The IP lines may be configured in a star or a meshed configuration. One of the advantages of a meshed configuration is that it removes the risk of a single point of failure within the network. Also the names and numbers (groups, line, services, etc) on the separate IP Office systems should be unique to reduce potential maintenance confusion.

Each IP Office system broadcasts UDP messages on Port 50795. These broadcasts typically recur every 30 seconds but BLF updates are potentially more frequent. There are no updates if there is no activity and the overall level of traffic is very low – typically less than 1 kbps per system.

From IP Office Release 2.1(35) and higher, SCN is supported between IP Office systems with differing software levels but network features will be based on the lowest level of software within the network. This option is intended to allow the phased upgrading of sites within a SCN and it is still recommended that all systems within a network are upgraded to the same level where possible.

If larger networks are required QSIG can be used to link multiple Small Community Networks together. Functionality between the communities is governed by the QSIG feature set.

IP500 Voice Networking License

On IP500 and IP500 V2 systems, Small Community Networking requires one or more additional licenses.

QSIG, H.323 and SCN capabilities are not enabled by default in the IP500 and IP500 V2. An additional license is required to enable this functionality with 4 simultaneous networking channels (no channel limit for QSIG). Additional channels can then be licensed in increments of 4. A Voice Networking license is still required to enable TDM QSIG, even though there is no limit to the number of TDM QSIG calls that can be made or received once licensed.

Internetworking with Other Avaya Products

IP Office will support the most appropriate way for communication with any other existing PBX's in a customer network, whether TDM or IP-based. With Avaya DEFINITY, MultiVantage, Avaya Integral Enterprise or Avaya Communication Manager (ACM), the protocols used will be QSIG or H.323 over T1, E1 or IP links

VoIP networking using H.323

IP Office (since release 1.1 in US and release 1.2 in EMEA) has been successfully tested to be interoperable over IP trunks with Avaya Communication Manager (ACM). The protocol supported is H.323 using industry-standard compression codecs (types G.711A, G.711MU, G.729A and G.723.1-6K3). The features currently supported are as follows:

- Desk to desk dialing (basic voice call)
- Calling/Connected Party ID number
- Calling/Connected Name Presentation
- Call Hold
- Call Transfer

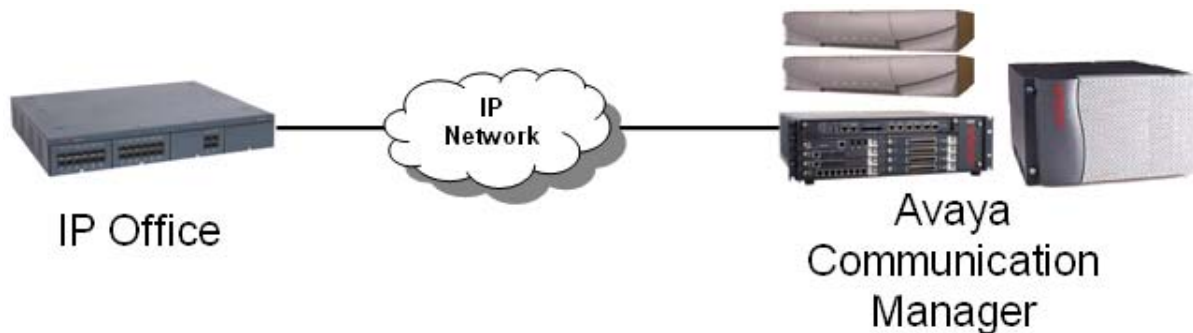

These features allow for simple networking needs between IP Office remote branches to a DEFINITY/ACM at the main site.

QSIG networking using T1/E1 links (TDM)

Alternatively QSIG may be favored as the chosen signaling standard within multiple vendor environments and provides the following supplementary services which are also available between IP Office and DEFINITY / MultiVantage/ I55 /ACM (equipped with the relevant RFA licenses):

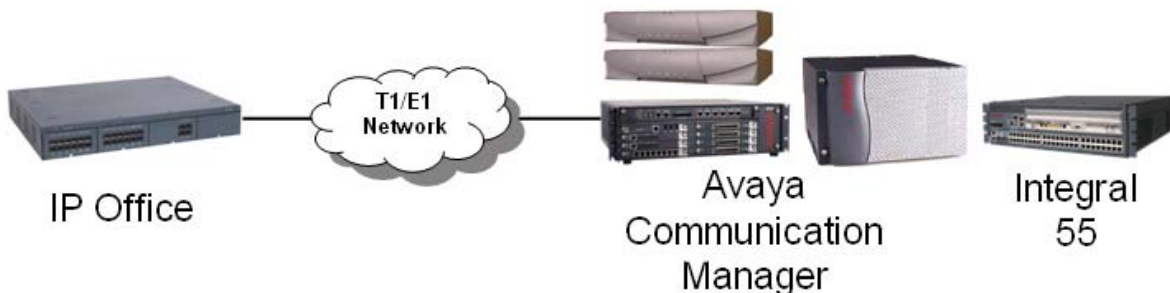

- Simple Telephony Call/Basic call (ETS 300 171/172)
- Circuit Switched Data Call/Basic call (ETS 300 171/172)
- Calling/Connected Line Identity Presentation (ETS 300 173)
- Calling/Connected Name Presentation (ETS 300 237/238)
- Message Waiting Indication (ETS 301 260/255)

Messaging Networking

There are 2 options available today to provide messaging interoperability between IP Office and Definity / MultiVantage / ACM. The first option provides Centralized Voicemail while the second allows Avaya voicemail systems to be networked. The requirements, functionality and restrictions are summarized below:

- IP Office to DEFINITY / MultiVantage / ACM connected to Intuity AUDIX™ over a QSIG link (E1/T1 or IP)

Incoming Call

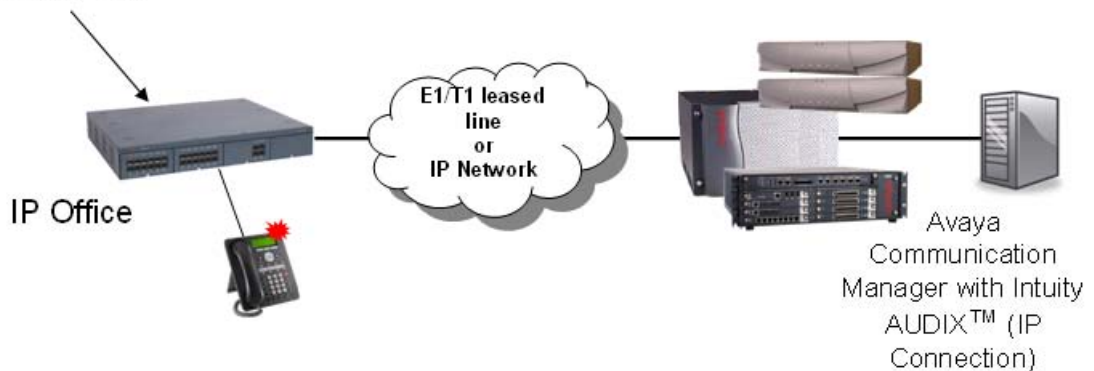

- No local Voicemail required on remote branch IP Office but AUDIX license required on every IP Office
- Requires Intuity Audix 4.4+ connected via C-LAN to DEFINITY 9.5+ (see IP Office Offer Announcement dated August 2003 for more information on compatibility)
- Maximum of 19 IP Offices can be supported on 1 INTUITY AUDIX™ server (20 total with DEFINITY/ACM occupying one slot)
- Requires QSIG and Private Networking licenses on DEFINITY / MultiVantage / ACM
- User mailbox with Message Waiting Light support
- Forward voicemails between users
- No auto attendant (enhancement currently being investigated)
- No call recording
- No queuing at remote sites
- No Fax over IP to AUDIX™
- No Small Community Networking support when AUDIX™ is configured on IP Office.

- Avaya IP Office VoiceMail Pro networked to Avaya Modular Messaging / Octel / Intuity AUDIX™ via Interchange / S3210

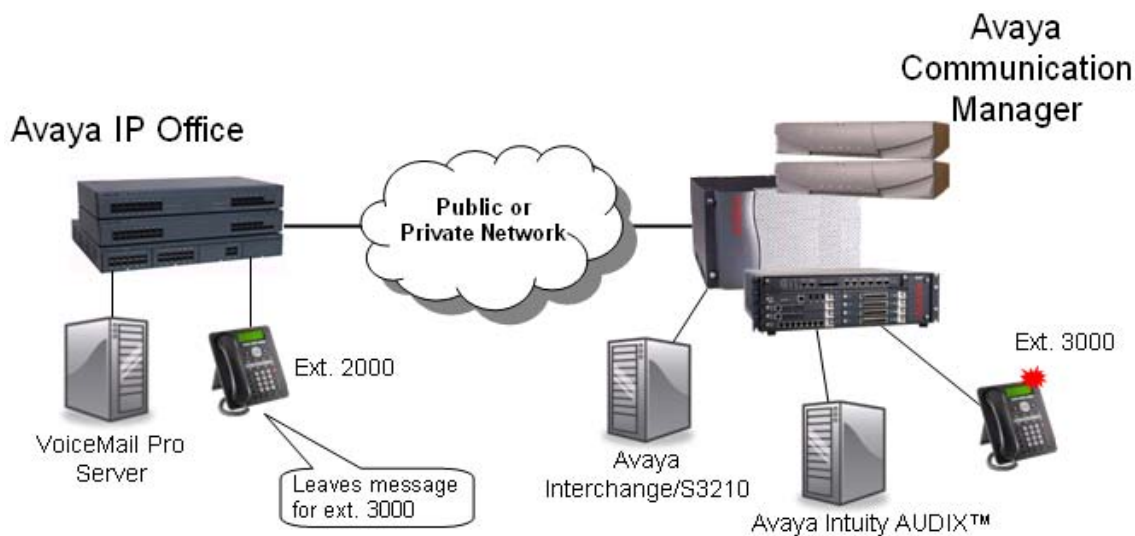

- Requires local VoiceMail Pro on every branch IP Office licensed with VoiceMail Pro Networked Messaging RFA
- Requires Avaya Interchange/S3210 on Modular Messaging, Octel or Intuity Audix
- Provides 2,000 remote mailboxes per VoiceMail Pro server i.e. per branch office (to be extended to 10,000 remote mailboxes by next VoiceMail Pro maintenance release)
- User mailbox with Message Waiting Light support
- Forward voicemails between known remote users
- Fully-featured VoiceMail Pro at every branch office
- VoiceMail Pro Networked Messaging will only accept an incoming voicemail message for a local mailbox. It will NOT forward it to a remote Voicemail server. If required, this facility is available through Avaya Interchange.
- VoiceMail Pro Networked Messaging is limited to Avaya Messaging Servers (not third-party messaging platforms).

Common Networking Features

Alternate Route Selection

Alternate Route Selection (ARS) allows calls to be routed via the optimum carrier. Time profiles can also be used to allow customers to take advantage of cheaper rates or better quality at specific times of day.

If a primary trunk is unavailable or congested, then ARS provides automatic fallback to an available trunk (e.g., analog trunk fallback if a T1 or SIP trunk fails, or use PSTN for SCN fallback).

Multiple carriers are supported. For example, local calls are to go through one carrier between specific hours and international calls through an alternative carrier. Carrier selection using 2-stage call set up via in-band DTMF is possible. It is possible to assign specific routes on a per user basis, e.g. only allow expensive routes to be used by critical staff.

Note: Existing Least Cost Routing (LCR) configurations are automatically converted to ARS when upgrading to 4.1 or higher.

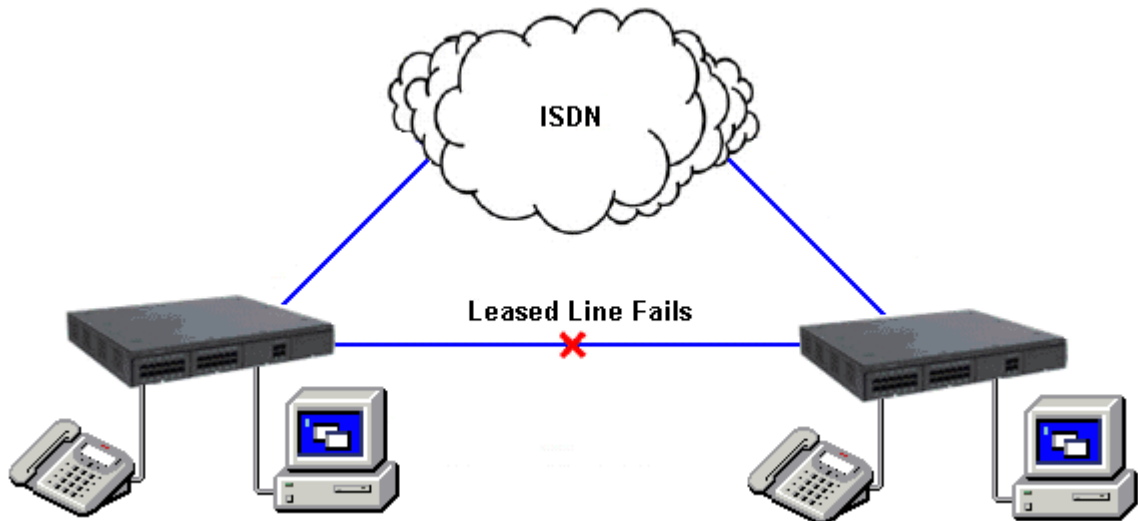

Network Numbering Schemes

IP Office uses fully flexible network numbering options. Dialed digits can be manipulated to add or remove digits, access codes etc. in order to fit into any numbering scheme. Two types of numbering schemes are commonly deployed - 'Linked Numbering' and 'Node Numbering' schemes. In linked numbering schemes each site within the network has a unique range of extension numbers and users simply dial the extension number of the called party. Often, linked numbering schemes are used in very small networks (< 5 sites) with less than 500 extensions. With node numbering schemes each site is given a node ID and this is prefixed by the user when dialing extensions at other sites. In this way extension numbers can be replicated across sites while still appearing unique across the network. Node numbering schemes are common in larger networks. Linked numbering schemes and node numbering schemes are sometimes both used within the same network with node numbering used at the large offices and linked numbering employed at clusters of satellite offices.

The following figures depict these two types of numbering schemes.

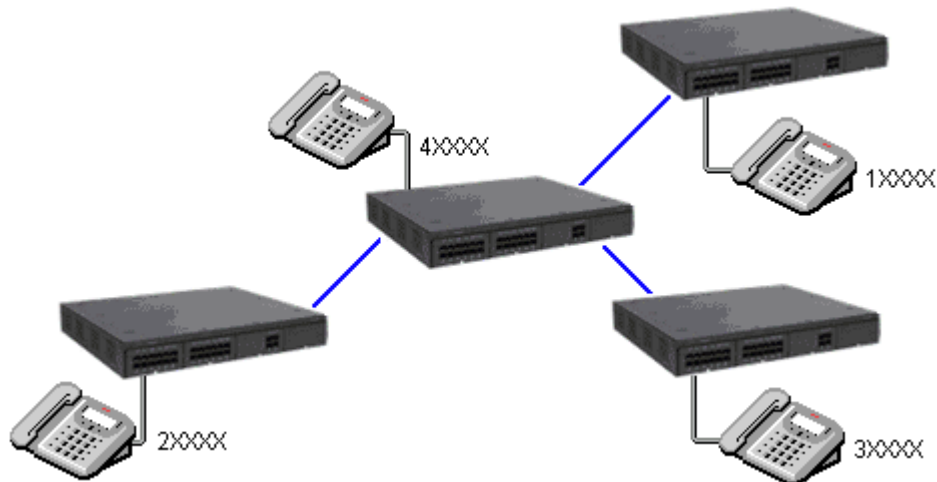

Linked Numbering Scheme

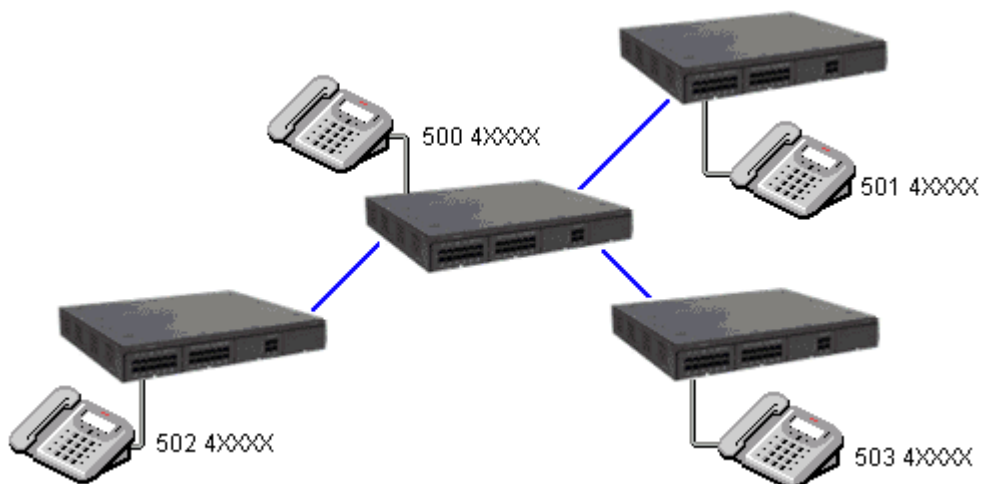

Node Numbering Scheme

Chapter 8.

Data Networking Services

8. Data Networking Services

LAN/WAN Services

The IP500 and IP500 V2 support a firewalled 2 port Layer 3 Ethernet Switch.

When computers on the LAN communicate they do not care where the destination is, they just send messages with the address of the destination. These messages are likely to be received at all other computers on the same network but only one – the target destination – will act on the message. Where the destination is on another network, the router is needed to be the "gateway" to the rest of the world and find the optimum route to send the message on to the destination. The router alleviates the need to establish and hold a call for the duration of a communication session (when messages or IP packets are being sent between source and destination) by automatically establishing a connection only when data is to be passed. Routers may be connected together using WAN (Wide Area Network) links that could be point-to-point leased lines, managed IP networks, Frame Relay networks or exchange lines (Central Office). The IP Office system supports all of these types of network connections.

IP Office has an integral router with support for bandwidth on demand that allows the negotiation of extra bandwidth dynamically over time. Where connection is over ISDN, IP Office initiates extra data connections between sites only when there is data to be sent or sufficient data to warrant additional channels. It then drops the extra channels when they are no longer needed. The calls are made automatically, without the users being aware of when calls begin or end. The rules for making calls, how long to keep calls up etc, are configurable within IP Office.

It is possible to have several different routing destinations or paths active at any time linking the office to other offices and the Internet simultaneously.

Internet Access

While the telephone is still the number one business communication tool, Internet access is becoming increasingly important for business-to-business communications. The ability to send and receive email, is now considered mandatory when dealing with many suppliers and customers, while access to the Internet for e-commerce applications and information has become vital.

IP Office systems provide shared, secure, high-speed access to the Internet via exchange lines (Central Office), digital leased line or IP VPN services.

Internet security concerns are addressed through the provision of an integrated firewall so removing the need for a standalone firewall. The firewall can be configured to cater for a variety of situations and will allow customers to control who can access external resources and when. The firewall isolates your private networks from the Internet, thereby ensuring that your network remains beyond the reach of hackers, while configurable service quotas can be set against a remote access service to ensure authorized users can gain access. Service Quotas place a time limit on outgoing calls to a particular IP Service so limiting costs. Each service can be configured with an alternative fall back, for example, you may wish to connect to your ISP during working hours and at other times take advantage of varying call charges from an alternative ISP. You could, therefore, set up one service to connect during peak times and another to act as fallback during the cheaper period.

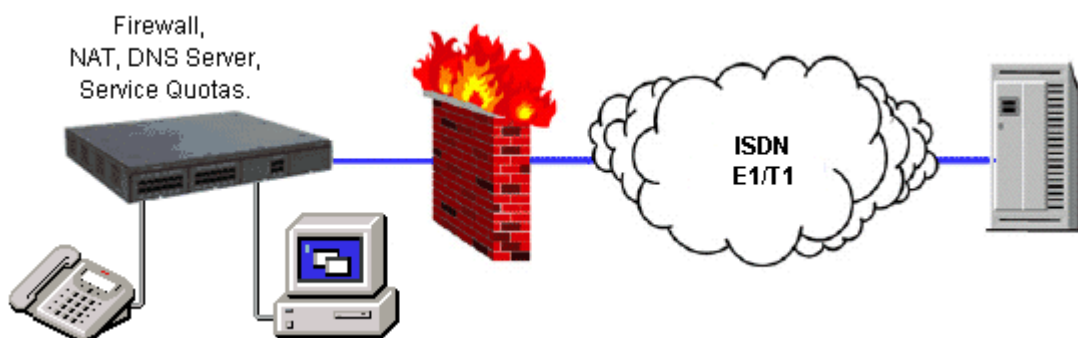

Internet Access

Remote Access Features

IP Office's integral firewall, service quotas and timebands all apply to remote access calls. Remote access security can be supplemented by CHAP (encrypted passwords) to verify the end users, or PAP which does not support encryption. Timebands can control the hours within which the remote access service is available.

A "trusted location" can be set for dial in. These are locations that the System will allow either data access, e.g. a user dialing in from home, or access to voicemail without a voicemail code for a user collecting their voicemail messages from a mobile. The trusted location is also the location the Voicemail Server will call to inform the user of a new message.

Conversely a "specified location" can be set which restricts remote access from only that location, this specified location can also be a designated dial back number thereby minimizing the threat of unauthorized remote access.

IP Office systems can also incorporate remote access dial back services so that if a user always remotely accesses the office from a single location e.g. their home, then after login verification the system will disconnect their call and dial them back. In addition to the added level of security dial back provides it can also be an excellent method of consolidating remote access charges onto the central office telephone bill.

In addition to remote access from Telephone Adaptors, all ATM4 trunk cards (including the IP500 V2 Combination Card ATM) support switching of the first analog trunk to an integral V.32 modem for remote access.

LAN to LAN Routing

All businesses now have a need for data routing whether it's a requirement to share resources such as email servers, file servers and internet gateways, or seamlessly transport data between sites or network to and from their customers and suppliers. This is why each IP Office platform offers IP routing as standard.

Embedding a router within IP Office removes the costs, complexity and additional points of failure of external WAN multiplexers by allowing data and voice traffic to converge and share the network resources of IP Office. These network resources can range from dial up ISDN connections, point-to-point leased circuits, managed IP networks or Frame Relay as IP Office supports all these types of network connections.

Data Networking Features

Integral 10/100 Mbit Layer 3 Ethernet Switch

Layer 3 switching is particularly useful in situations where it is desirable to have a 'trusted' and 'unsecured' network, where the 'unsecured' network is uncontrolled and carries public traffic on it.

It is possible to set up a firewall between two LAN segments using the IP Office layer 3 switch. IP500 and IP500 V2 support a two-port Layer 3 Ethernet switch with the firewall between them. Both of these switched ports have their own IP addresses (LAN1 and LAN2) and in order for traffic to pass from one port to the other, a route is configured in the system's routing tables.

DHCP Server

IP Office can manage your IP Network for you through its integral DHCP Server. IP Office can be configured to hold a pool of IP addresses for users on the Local Area Network. When a user powers up their PC, the system will allocate them an IP address for the duration of their session. The DHCP server also provides the user's PC with the address of the Domain Name Service (DNS) server and the Windows Name Service (WINS) server. Alternatively, for customers who have a separate DHCP Server, IP Office can be configured to obtain its address from that DHCP server or be set with its own static IP address. Both IP500 and IP500 V2 have two independent DHCP servers, one dedicated to each of the Layer 3 switched LANs.

Leased Line Support

IP Office is capable of connecting to leased line services.

IP Office WAN services are supported over E1/T1 PRI trunks and BRI trunks. E1/T1 trunks can be configured to operate in a fractional mode for 'point to multi-point' applications i.e. a single 2M interface could be treated as 3 x 512K and 8 x 64K going to 11 different locations. When using T1 as a Leased Line it is possible to use the same circuit for switched circuit services. Not all types of leased line are available in all territories, check for availability.

Dial-Up Circuit Support

Where the amount of traffic does not justify the cost of a dedicated leased line, the system can provide data connectivity via ISDN dial-up circuits using its E1/T1 or Basic Rate trunks. Where data speeds greater than a single channel are required (64K/56K), additional channels can be added to the call as and when they are needed.

Point-to-Point Protocol (PPP)

PPP is an industry standard Wide Area Networking Protocol, that allows inter-working with a wide range of 3rd party routers. PPP is used over dial-up or leased line circuits where a single channel is used to connect the two locations together. e.g. A single channel maybe a 64K channel on a dial-up circuit or a 256K leased line etc.

Multi-Link Point-to-Point Protocol (ML-PPP)

IP Office supports Multi-Link PPP allowing additional calls to be made where bandwidth greater than a single channel is required. The maximum number of channels available to data can be set on a service-by-service basis. When the available bandwidth reaches a user defined limit additional channels can be automatically added. Similarly, when traffic falls then the number of channels in use can be automatically reduced. If there is no data traffic on any of the channels in use then all lines can be cleared. Since most carriers have a minimum charge for calls, the period that a channel has to be idle before clearing is configurable. Through these mechanisms call costs can be effectively controlled while ensuring that bandwidth is available as and when it is needed.

Frame Relay

Frame relay is a wide area networking protocol based on the X.25 protocol. Individual network connections are multiplexed over a common medium by the use of Permanent Virtual Circuits (PVC). This allows a single Leased Line to provide connectivity to a number of different locations. Frame relay is currently implemented in IP Office as a CPE or 'router end' protocol over WAN connections. IP Office supports both PPP and RFC1490 encapsulation with fragmentation of large data packets to provide voice quality of service.

Service Quotas

IP Office can be configured to limit the maximum number of minutes that a service, such as Internet Access, is available for each user. This is the sum total of calls made and does not include periods of inactivity. Once the quota has been used the service is no longer available. The quota can be either automatically refreshed daily, weekly or monthly or manually refreshed by dialing a secure feature code on a handset.

Time Profiles

Time profiles set the operational times for service. For example, a time profile could be set up to make Internet Access available to staff only during lunch times. Using time profiles it is also possible to define an alternative service to operate outside the operational hours of the main service. This may be used to take advantage of alternative tariffs at off peak periods. Switching to this fallback service can also be controlled manually by dialing a secure short code from a handset. This can be particularly useful in allowing quick restoration of service in the event of an ISP failure. This feature also applies to days of the week or specific calendar dates.

Password Authentication Protocol (PAP)

PAP is a method of authenticating the remote end of a connection using unencrypted passwords.

Challenge Handshake Authentication Protocol (CHAP)

Challenge Handshake Authentication Protocol allows an incoming data call to be authenticated using encrypted passwords. The system also provides the option to periodically reaffirm the authenticity of the caller during the data call.

Data Header Compression

IP Header Compression (IPHC) reduces the header size of the data packet to gain bandwidth efficiency over Wide Area Networks, but adds to transmission latency.

Data Compression

IP Office supports both Microsoft Point to Point Compression and Stac Lemple Ziv to provide greater throughput on slow speed wide area network links.

Bandwidth Allocation Control Protocol (BACP)

Bandwidth Allocation Control Protocol allows the negotiation with the remote end of the data call to request additional calls to be made to improve aggregate data throughput.

Callback

Three types of call back are supported

- LCP (Link Control Protocol)
After authentication the incoming call is dropped and an outgoing call is made to a predefined number to re-establish the link.
- Callback CP (Microsoft's Callback Control Protocol)
After authentication from both ends, the incoming call is dropped and an outgoing call to a predefined number made to re-establish the link.
- Extended CBCP (Extended Callback Control Protocol)
Similar to Callback CP however, the Microsoft application at the remote end will prompt for a telephone number. An outgoing call will then be made to that number to re-establish the link.

Domain Name Service (DNS) Proxy

Domain Name Service servers provide the translation of names such as www.avaya.com to the domain's IP address required to establish a connection. IP Office provides this service to PCs on the network by proxy.

Network Address Translation (NAT)

Network Address Translation is a mechanism that allows you to use different IP address on your private network behind a router with a public IP Address. When connecting to the Internet, ISPs typically want a customer to use an IP address they have allocated. Using NAT this is easily accommodated, eradicating the need for the customer to change their network numbering scheme and providing additional security to the internal users as their address is hidden to the public.

Typically, a company maps its internal network addresses to a global external IP address and unmaps the global IP address on incoming packets back into internal IP addresses. This helps ensure security since each outgoing or incoming request must go through a translation process. This also offers the opportunity to qualify or authenticate the request or match it to a previous request. NAT also conserves the number of global IP addresses that a company needs.

Proxy Address Resolution Protocol (ARP)

Support for Proxy Address Resolution Protocol allows IP Office to respond on behalf of the IP address of a device connected to it when receiving an ARP request.

Auto Connect

If a service is idle, that is no one is using the Internet, Auto Connect allows the IP Office to periodically connect to a service. This is ideal for mail polling to retrieve email from an Internet Service Provider. An 'Auto Connect Time Profile' controls the time period during which automatic calls are made, for example not at weekends or during the middle of the night.

Firewall

IP Office integrated firewall provides packet filtering of the most common IP protocols including File Transfer Protocol (FTP) and Internet browsing (HTTP). Each protocol passing through the firewall can be restricted/allowed access in four different ways:

- Drop
No sessions via this protocol will be allowed through the wall
- In
An incoming session can "punch a hole" in the wall to allow traffic in both directions
- Out
An outgoing session can "punch a hole" in the wall to allow traffic in both directions
- Bothway
An incoming or outgoing sessions can "punch a hole" in the wall to allow traffic in both directions.

In cases where a protocol is not supported by default, the firewall can be customized to control packets based on their content.

IP Office allows the configuration of as many firewalls as needed through IP Office Manager. This permits different security regulations to be applied to individual dial-in users and data services.

Light-Weight Directory Access Protocol (LDAP)

IP Office supports LDAP directory synchronization. This allows the telephone number Directory (names and telephone numbers) held in IP Office to be synchronized with the information on an LDAP server (limited to 5000 entries). Although targeted for interoperation with 'Windows 2000 Server Active Directory', the feature is sufficiently configurable to interoperate with any server that supports LDAP version 2 or higher.

Remote Access Server (RAS)

IP Office provides RAS functionality allowing external users to dial in to the local area network from modems, telephone adaptors and routers. Several of the previously described features and services can be applied to the dial-in users to create a powerful Remote Access Server. Dial-in users can be authenticated using either PAP or CHAP. Once authenticated the DHCP server can automatically assign the user an IP address to use while connected to the LAN. Individual time profiles and firewalls can be applied to the user restricting what they have access to and when they have access. For further security and accounting ease, IP Office can automatically call a user back. This keeps the cost of the telephone call on the company telephone bill removing the need to process individual expense claims.

Routing Information Protocol (RIP)

RIP is a distance vector protocol that allows routers to determine the shortest route to a destination network. It does this by measuring the number of intermediary routers that need to be traversed to reach the destination network. If more than one route exists to the same destination the shortest route is used. If a fault occurs on the shortest route it will be remarked as being infinite and any alternative route will become the new shortest route. This behavior can be used to add resilience into a data network. Where a customer has an existing data network comprising of third party routers, IP Office added to the network can provide back up using its routing and dial-up capability. RIP enabled routers share their knowledge of the network with each other by advertising and listening to routing table changes. IP Office Supports both the RIP I and RIP II standards.

VPN: IPSec Tunneling



IPSec tunnels allow a company to pass data between locations over unsecured IP networks such as the public internet. The company data is secured using 3DES encryption making it unintelligible to other parties that might be 'eaves dropping' on the traffic. Tunneling can be applied to link offices together or provide workers access to the office over the internet. All IP Office systems support up to a total of 256K worth of encrypted traffic to multiple locations. Initially, inter-working is supported only between IP Offices that are connected either directly on a WAN port or via the LAN using a 3rd Party router. IPSec is optional and enabled on IP Office through a License Key.

Note: Check with Avaya for supported scenarios and 3rd party devices.

VPN: Layer 2 Tunneling Protocol

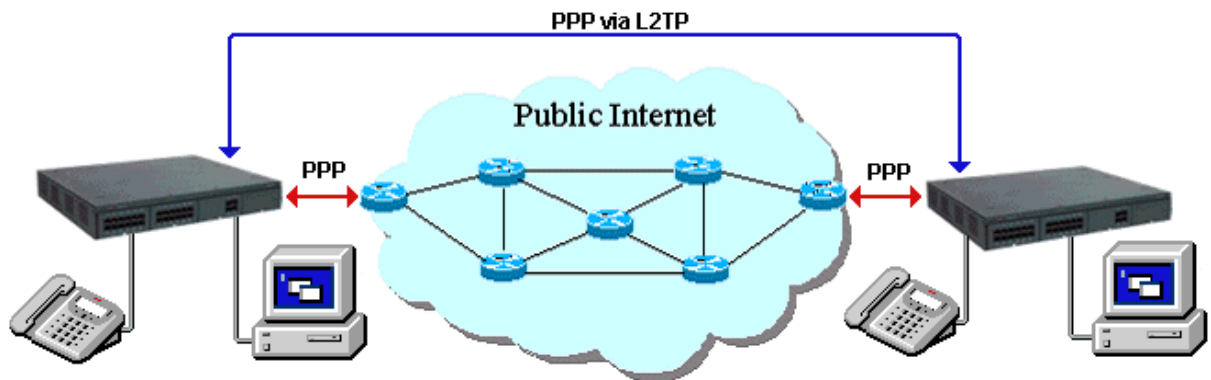

PPP authentication using PAP or CHAP takes place between directly connected routers only. When using a public IP Network to connect sites this authentication takes place between the customer owned router and the service provide router that it is connected to. In some circumstances it is desirable to authenticate between the customer owned routers, jumping over all the intermediary routers of the service provide network. Layer 2 Tunneling Protocol allow this to happen by facilitating a two stage authentication, firstly with the service provider router then the customer router on the remote network.

Chapter 9.

User Call Control

Applications

9. User Call Control Applications

Avaya provides the following call control application with IP Office Release 6:

- [one-X Portal for IP Office](#) ^[202]
one-X Portal for IP Office is a server based applications that the user accesses with their web browser. It can only be purchased as part of the IP Office Office Worker, Power User and Teleworker user licenses.

one-X Portal for IP Office

The one-X Portal for IP Office is an application that provides users control of their telephone from a networked PC.

one-X Portal for IP Office can be used with any IP Office extension; analog, digital or any IP telephones, wired or wireless, and is available as part of the IP Office Office Worker, Power User or Teleworker user licenses only.

one-X Portal for IP Office is a server based application that the user accesses via web browser.

Via separate gadgets, one-X Portal for IP Office provides easy access to telephony features, call information, call and conference control, instant messaging, directory and VoiceMail Pro mailbox.

The screenshot displays the Avaya one-X Portal for IP Office interface. At the top, the user is logged in as MarkG(675) and is available. The interface is divided into four main sections:

- Calls:** Shows a call in progress with agent 'Agent A (288)' and a timer at 00:00:04. Buttons for 'Drop', 'Hold', 'Record', and 'Conference' are visible.
- Directory:** Shows a list of contacts including Alex, Ashley, Andy, Walter, Brad, Dave, Richard, Brian, Emma, and Graham. A search bar is present at the bottom.
- Messages (7 unread):** Shows a list of messages with columns for State, From, Time, and Length.
- Call Log:** Shows a list of call records with columns for Type, Name, Time, Duration, and Calls.

Calls Gadget

Caller ID/Name Presentation

Caller ID is presented as standard (where provided) allowing users to see who's calling before answering. The caller's phone number and name (if known to IP Office) are clearly shown in the call status area.

The same information is also displayed should a second incoming call be presented, allowing users to easily switch between calls.

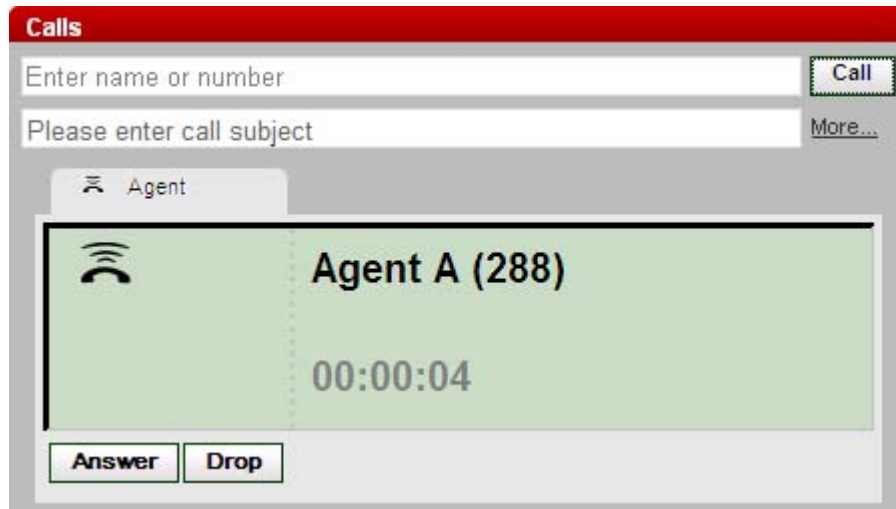

Desktop PC Telephony Controls

one-X Portal for IP Office has telephony buttons in the call gadget that activate standard telephone functions such as Answer, Drop, Hold, Retrieve, Record, Consult and Transfer so that users don't need to remember IP Office specific feature codes. These functions are context sensitive and appear depending on the status of the call. Keyboard shortcuts are available for Answer, Hold, Drop and Call functions and can be configured by the user.

Active calls can be easily parked by clicking on a park slot whilst displaying the active call. Four Call Park slots/zones, which can be shared between users and operators, or within a department on the same IP Office system, further add to the ease with which the entire call handling process is streamlined with one-X Portal for IP Office. Such parked calls can be retrieved either through one-X Portal for IP Office, Phone Manager, SoftConsole or a desktop phone. The call park slot names can be configured by the user.

Conferencing Controls

one-X Portal for IP Office allows the setting up of an ad-hoc conference call from calls on hold and/or the directory, or a meet-me conference. It is possible to configure the Conference ID of the user for meet-me conferences.

Once the conference is set up the conference originator will have the following functions:

- mute/unmute a party/oneself
- mute/unmute all
- drop a party from the conference
- hold the conference while others keep talking
- record the conference

Call Log Gadget

Call History

The call log displays details of calls you have made, received and missed and it will report the last 30 calls. Users can use the call log to make a call or add the caller to the Personal Directory.

The call log shows the actual call history, independent of whether the user was logged in at the time or not. The call log is centralized and also available on the desktop phone.

Calls are ordered in 4 tabs:

- All: all calls.
- Incoming
- Outgoing
- Missed

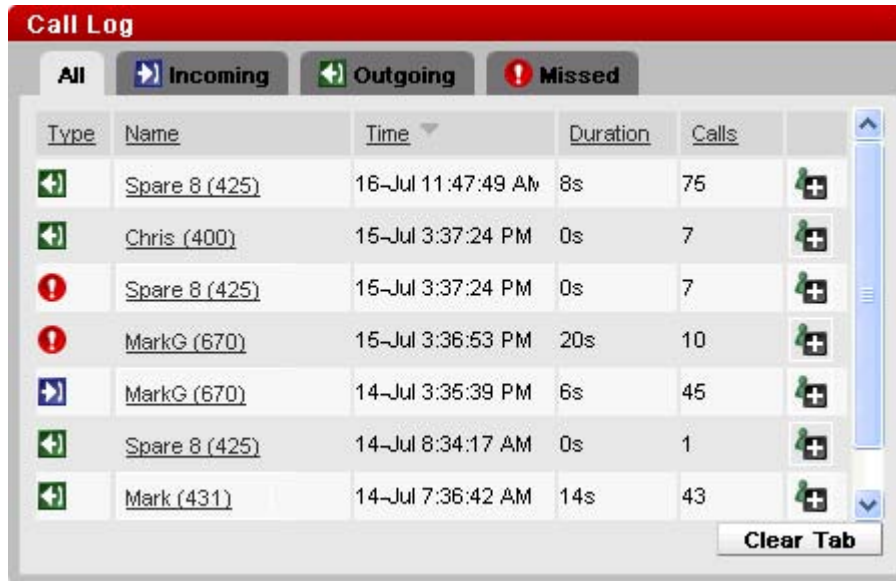

Type	Name	Time	Duration	Calls	
Outgoing	Spare 8 (425)	16-Jul 11:47:49 AM	8s	75	+ Add
Outgoing	Chris (400)	15-Jul 3:37:24 PM	0s	7	+ Add
Missed	Spare 8 (425)	15-Jul 3:37:24 PM	0s	7	+ Add
Missed	MarkG (670)	15-Jul 3:36:53 PM	20s	10	+ Add
Incoming	MarkG (670)	14-Jul 3:35:39 PM	6s	45	+ Add
Outgoing	Spare 8 (425)	14-Jul 8:34:17 AM	0s	1	+ Add
Outgoing	Mark (431)	14-Jul 7:36:42 AM	14s	43	+ Add

Clear Tab

Each tab can be ordered by name, number, time of the call, duration, number of calls and call type. The order can be ascending or descending.

To make a call from the call log, the user simply clicks on the number they wish to call.

Messages Gadget

Voicemail Access

one-X Portal for IP Office will show new, saved and old voicemails received and provides access into the user mailbox allowing the user to play, rewind, fast-forward, save and delete messages.

The voicemails can be ordered by state (new, saved, read, private, urgent), caller, called party, time and length. The order can be ascending or descending.

The user can easily call back the caller who left a message from the message gadget.

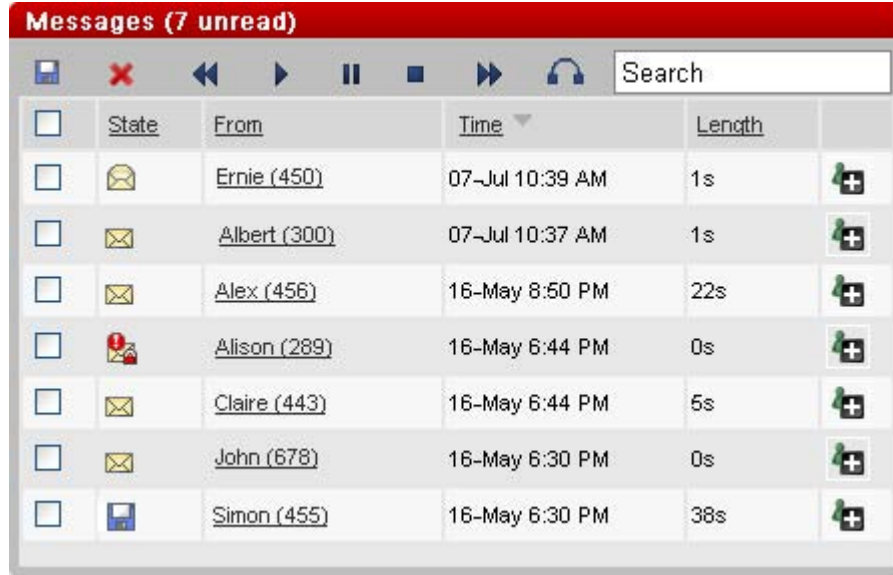

Directory Gadget

Directories

one-X Portal for IP Office can display several directories of names and associated telephone numbers.

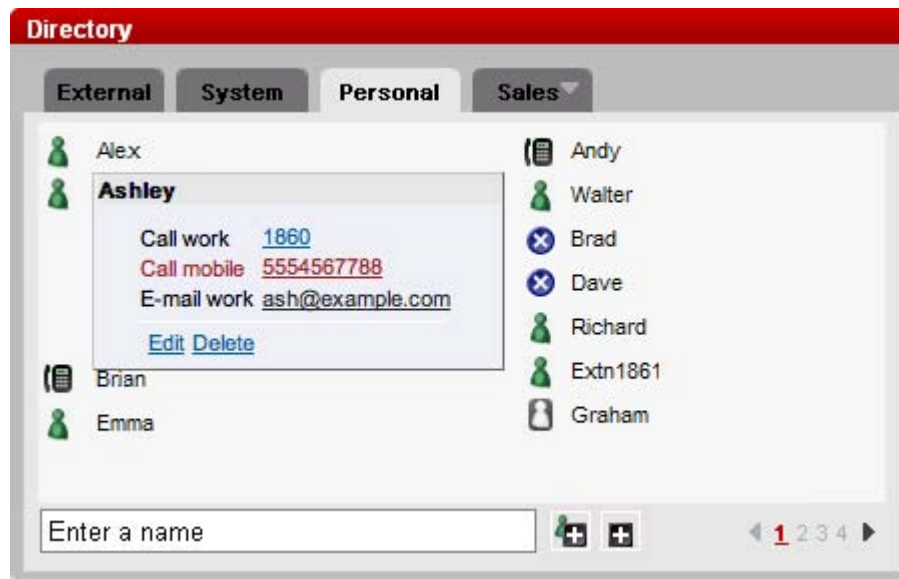

- **Personal Directory**
This is the user's own directory of names and numbers. The user can associate multiple numbers (e.g. work, home, mobile, etc.) with a name and select which number to use when making a call. They can also edit and change the directory entries. The personal directory can contain up to 100 entries. The personal directory is common with the 1400, 1600 and 9600 Series phones (as well as T3 phones in selected EMEA countries).
 - The one-X Portal for IP Office user can add up to 4 additional tabs for personal directory contacts,
- **System Directory**
This is the directory of names and numbers from the IP Office telephone system plus all the users and groups on the telephone system. These entries cannot be changed, but the user can copy a system directory entry into your personal directory and modify it.
- **External Directory**
The system administrator can configure one-X Portal for IP Office to access one external directory (Active Directory / LDAP).

Searching the directories is easy: with the Personal Directory and the System Directory, as you enter a name or number in the box at the bottom of the tab, only matching directory entries will remain in view.





With the External Directory, you must enter a name or number to perform a search.

The user can make a call directly from the directory gadget by clicking on the number associated with the entry. If more than one number is available for this entry, they can choose which one to call.

User Status/Presence

For the directory entries of other IP Office users, one-X Portal for IP Office will indicate the status of the user at their work number. This status is available for users across an IP Office Small Community Network.

The status can be:

State	Icon	Description
Available		The normal state for a user when their extension is not in use.
Busy		The normal state for a user when their extension is on a call.
Do Not Disturb		The user has set Do Not Disturb. Calls to them will go to voicemail if enabled or else get busy tone unless you are in the user's Do Not Disturb exception list.
Logged Out		The user has logged out from their phone. Calls to them will most likely go to voicemail if available.
Other		This icon is used when the status is not known.

Presence within one-X Portal for IP Office allows the user to create sets of call redirection settings. Through the configuration tab the user can create different Presence entries and associate different rules to each such as forwarding to a different number or Do Not Disturb. In case of Do Not Disturb, the user can establish a list of numbers (DND exceptions) from whom the user wants to receive calls.

Instant Messaging Another one-X Portal for IP Office User

From the Directory entry of a user the option chat with allows the establishment of an instant messaging session. Such sessions can be established only with other logged on one-X Portal users and can be established while on multiple calls.

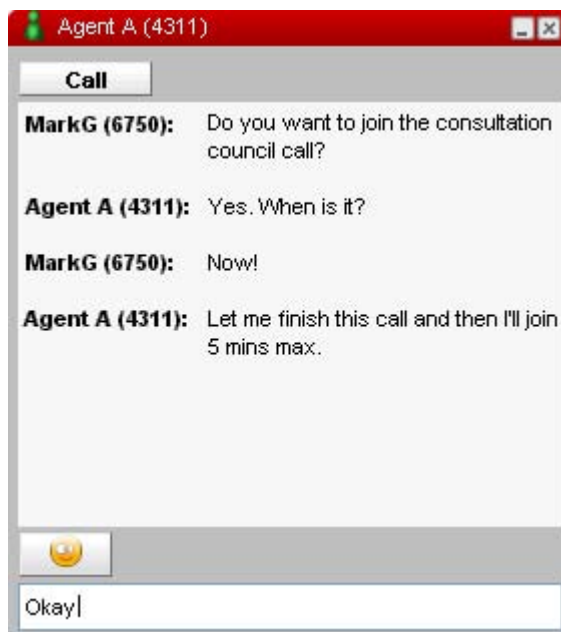
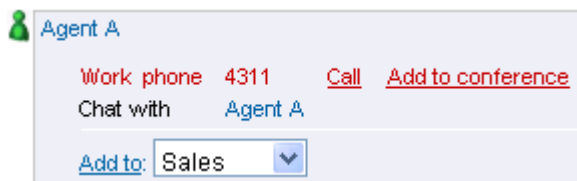

Profiles

By setting and creating using profiles the user is able to easily control where your calls are directed and how they are treated.

There are 3 default profiles, called Office, Mobile and Home. These can be edited but not deleted. The user can create up to 5 additional profiles. A special profile called Detected may also appear and it is displayed when the current telephone system settings don't match any of the profiles.

By selecting which of the saved profiles is the current one, the user applies that set of settings to the telephone system.

When creating or editing a profile, there are 4 settings that the user will have to select:

- Mobility - The user can choose between:
 - The default desk phone
 - A number to forward the calls to
 - Mobile Twinning with the number to twin
 - Telecommuter with the number where the user is based
- Voicemail - The user can choose to activate/deactivate the following options
 - Voicemail on call not answered
 - Voicemail ringback
 - Voicemail Outcalling
 - Voicemail to be listened on PC or on phone.
 - Active Greeting – The user can choose which recorded greeting to make active.
- Call Pick Up – on/off

Call Assistant

Call Assistant is an optional browser plug-in that enables the following functions:

- Screen pop when receiving a call.
The screen will show the name (if in the personal or system directory) and number of the caller and the user can retrieve the call by clicking on the name or the number. It will also give the option to retrieve the Outlook 2003/2007 Contacts entry for that caller.
- Click-to-dial
It allows the highlighting of phone numbers in various applications, like Microsoft Word or Excel. The user can then call that number by clicking on it.

Server, Browser and Other Requirements

- Phone support
Any telephone connected to IP Office, although handsfree operation is only supported on suitable Avaya Digital and IP telephones.
- Server and Browser requirements
 - one-X Portal for IP Office supports the following browsers:
 - Microsoft Internet Explorer versions 7 and 8.
 - Mozilla Firefox version 3.0 and above.
 - Windows Safari and Apple Safari 3.1 and above.
 - The server requirements are:
 - Intel Pentium D945 core/AMD Athlon 64 4000+; with 3 GB RAM and 20 GB free hard disk space.
 - OS supported: Windows Server 2003 (32 and 64 bit).
 - Always refer to the latest Avaya IP Office Technical Tip or Technical Bulletin for any updated information with regard to Operating Systems, Service Packs or PC hardware.
 - Licensing
one-X Portal for IP Office requires a one-X Portal for IP Office license for each user. This license is part of the IP Office Power User, Office Worker or Teleworker user licenses and is not available separately. The Telecommuter mode and SoftPhone are available only with Power User and Teleworker. Softphone does not require an Avaya IP Phone license on IP Office, unlike the Avaya IP hard phones.
 - PC Requirements for IP Office Video Softphone
- Processor:
 - Minimum: Pentium 4 2.4 GHz or equivalent, Video Card with DirectX 9.0c support
 - Optimal: Intel Core 2 Duo or equivalent, Video Card with DirectX 9.0c support.
- Memory:
 - Minimum: 1 GB RAM
 - Optimal: 2 GB RAM
- Hard Disk Space: 50 MB
- Operating System: Windows XP Service Pack 2, Windows Vista, 32-bit and 64-bit arch, Windows 7 32-bit and 64-bit.
- Additional: Microsoft Windows Installer 3.1, Microsoft .NET 3.5 SP1, Microsoft VC 9.0 Runtime Service Pack 1
- Connection: IP network connection (broadband, LAN, wireless)
- Sound Card: Full-duplex, 16-bit or use USB headset

Note that these are recommendations. Depending on other applications on the PC, Softphone cannot guarantee uninterrupted Voice and/or Video quality. While Softphone runs with high priority on the PC in order not to be impacted by normal applications other programs with similar priority could impact Softphone performance. Example applications could be other Multimedia or communication applications like web-sharing programs or programs that are essential for PC performance like some Virus-scanners or firewall programs.

IP Office Video Softphone

With Release 6 IP Office introduces – as part of the Teleworker and Power User package – a new Softphone application.

The Softphone is a full feature telephony client that supports standard telephony features on a PC running supported Microsoft operating systems including new Microsoft Windows 7.

Support of several audio options including support of wireless headsets with full hook-switch support provides a flexible telephone option, especially for people on the move.

Softphone is part of the Teleworker and the Power user package. An applicable Teleworker/ Power User license for the user of the Softphone is required; however Softphone does not require any additional license, e.g. no (Avaya) IP-station license.

Softphone can run in two different operating modes:

- a) Softphone client mode: The Softphone provides its own User interface, similar to a standard IP Office telephone for making calls, transferring calls, multiple call appearances or making conference calls. A programmable feature button list allows one-touch access to standard IP Office features. This is the preferred usage scenario for customers not running other IP Office productivity applications like one-X portal. It is also the preferred operation mode for users who want to smoothly migrate from their desktop phone or who use Softphone only occasionally and prefer a phone-centric user-interface, with optional dial pad and standard phone feature keys. The user interface is flexible, allowing adjustment for personal preferences with detachable specific windows like the directory and call log window. The attached picture shows the Softphone with dial pad and feature keys, plus a view of the contacts of Softphone.

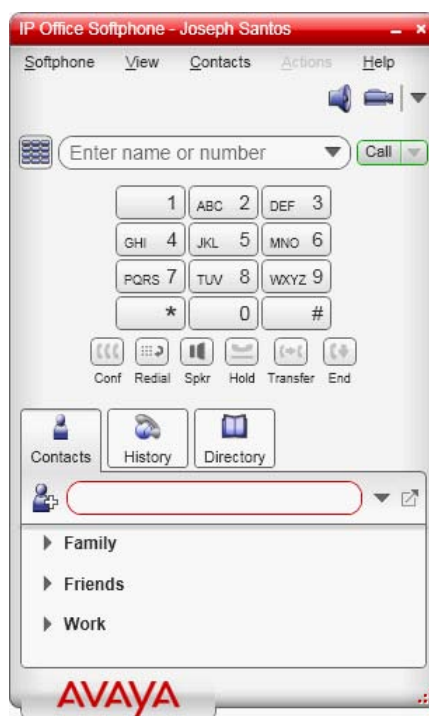

Softphone can also be configured to be minimized to the system tray when not in use to smaller or larger configurations to save desk-space.



IP Office Softphone with dialpad, active call and Call Log (History)



Deskphone buttons for IP Office Features

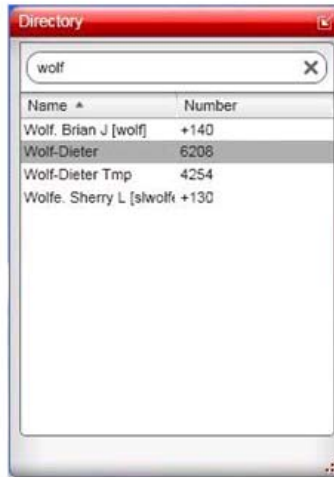

IP Office Directory Sample



Video Picture: Active Video Call with self-view



IP Office Softphone in smallest mode

b) Application mode: the Softphone runs in the background and standard call control is accomplished through productivity applications, such as one-X Portal for IP Office that is part of the User profiles described above.

If run with one-X portal it provides the following additional value:

1. Consistent user interface when using one-X Portal with a desktop phone, in telecommuter mode or in combination with Softphone.
2. Off-line call log with updates even when Softphone is not logged in
3. Additional features of one-X Portal e.g. presence and instant messaging.

Video Support

As well as audio calls, IP Office Video Softphone supports end to end video calls on a single IP Office or within an IP Office Small Community Network. Currently, video is limited to end to end calls, no multi-party conferencing is supported.



Video adds a new level of interaction to the standard phone communication so this is especially useful for users working from a remote location, needing to get in touch with colleagues in the main site or when used in an IP Office Small Community Network.

Feature Overview

The following feature overview is applicable when using the Softphone in Client mode. When used in application mode, functionality depends on that application.

- Making and receiving calls
- Multiple Call Appearances (No bridged or line appearances)
- Hold, transfer (attended and unattended)
- Message waiting with direct voicemail access
- Audio Conference (IP Office based)
- Local call log, local directory
- Access to IP Office directory (system, corporate, personal)
- Feature keys for up to 12 IP Office features like:
 - Forwarding (various methods like all, busy, no answer)
 - Park/Unpark
 - Pick up (any, group, member)
 - Voice-Mail on/off

Features keys can be selected and self administered from a list of features that is downloaded from IP Office.

If equipped with an audio device with hook switch control, Softphone allows calls to be made or answered even when the screen-saver of a PC is activated and the PC is locked. Until the PC is unlocked, no screen will be shown but ringing calls can be accepted through e.g. a headset with hook-switch.

Licensing and Provisioning

IP Office Video Softphone forms part of the Teleworker or Power User profile. A user can log onto the Softphone using their normal username and password. License entitlement will be checked against that user before the login is accepted.

Unlike Avaya hard phones, Softphone does not require an Avaya IP Phone License to work on IP Office.

While the Softphone is a thick client application, it is extremely easy to install and provision. Installation of the application on a standard PC requires minimal to no configuration as all provisioning of the product is done from the IP Office as a provisioning server.

If a DHCP server is present and set up correctly, Softphone will completely configure itself. The user only needs to enter the username and password to get connected.

If DHCP is not available, the user needs to enter a single IP address of the IP Office; all other parameters will be set automatically.

Softphone can be set up so that, when the PC starts up, the application is automatically started with the default username and password. The user can disable automatic login as well as interrupt it any time.

Username and Twinning

When logged in to Softphone with their username and password, the user will automatically be logged off from their existing desktop extension, so the user is fully available on their normal number without any additional steps.

For users that are using a physical telephone e.g. in the office, this is very convenient as they do not use a different extension for Softphone calls. All calls will be routed automatically to the Softphone when logged in. There is no need to use twinning to tie the Softphone to the standard desktop phone.

Supported Audio and Video Hardware

Softphone can run with any Windows sound device supporting full-duplex quality.

If possible, audio devices are automatically detected and allocated to the Softphone.

Softphone supports simultaneous operation of two sound devices, e.g. a headset or USB handset for normal calls and a USB handsfree unit for handsfree operation. It is possible to switch between the sound devices at any time during the call.

For alerting, in addition to that the PC speakers can be activated to ring the phone.

For ease of use, similar to desktop phones, Softphone supports USB devices for audio as well as for call control, e.g. accepting and terminating a call. Softphone supports the "HID" standard for USB devices allowing generic USB devices to be configured.

A number of USB devices have been tested with Softphone for interoperability, including Hook switch control as well as dialing (if supported by that device).

- Audio Devices:
 - Plantronics DSP (USB headset)
 - Plantronics 510 (Bluetooth headset with USB base)
 - Plantronics CS50 (USB wireless headset)
 - GN Netcom 8120 (USB headset adapter for GN Netcom headsets)
 - Yealink W1DL (Cordless USB phone with Dialpad)
 - Yealink P1K (Corded USB Phone with Dialpad)
 - Generic USB soundcard and USB HID interface support (with configuration assistant)
- Video Cameras:
 - Logitech QuickCam Pro 4000, 5000, 9000
 - Creative Webcam NX Pro
 - Microsoft Lifecam VX-3000

Supported Audio and Video Codecs

Softphone supports G.711 and G.729 Audio Codecs. Audio Codec negotiation is done by IP Office in order to ensure best quality for local or SCN calls. At login, the user can select the default mode, e.g. best quality or low bandwidth for remote operation.

For Video, Softphone supports H.263, H.263+ and H.264 Video Codecs with resolution of up to 640*480 pixels and 30 frames per second.

Resolution	Pixel	Typical Net Video Bandwidth Requirement	
		H.263	H.264
Low	176 x 144 (QCIF)	64 kbps	45 kbps
Standard	320 x 200 (QVGA)	162 kbps	114 kbps
High	640 x 480 (VGA)	776 kbps	545 kbps

Note: The above numbers show an average bandwidth requirement but peak usage might be higher. The above numbers do not include the audio-bandwidth.

Supported Languages

Currently the following languages are supported:

- English,
- French,
- Spanish,
- Italian,
- Portuguese

Over the time, new languages can be added to the product.

PC Requirements

- Processor:
 - Minimum: Pentium 4 2.4 GHz or equivalent, Video Card with DirectX 9.0c support
 - Optimal: Intel Core 2 Duo or equivalent, Video Card with DirectX 9.0c support.
- Memory:
 - Minimum: 1 GB RAM
 - Optimal: 2 GB RAM
- Hard Disk Space: 50 MB
- Operating System: Windows XP Service Pack 2, Windows Vista, 32-bit and 64-bit arch, Windows 7 32-bit and 64-bit.
- Additional: Microsoft Windows Installer 3.1, Microsoft .NET 3.5 SP1, Microsoft VC 9.0 Runtime Service Pack 1
- Connection: IP network connection (broadband, LAN, wireless)
- Sound Card: Full-duplex, 16-bit or use USB headset

Note that these are recommendations. Depending on other applications on the PC, Softphone cannot guarantee uninterrupted Voice and/or Video quality. While Softphone runs with high priority on the PC in order not to be impacted by normal applications other programs with similar priority could impact Softphone performance. Example applications could be other Multimedia or communication applications like web-sharing programs or programs that are essential for PC performance like some Virus-scanners or firewall programs.

Feature Summary

Feature	Phone Manager Lite	Phone Manager Pro	one-X Portal for IP Office
Web browser based	-	-	Yes
OS independent (Windows, Linux, Mac support)	-	-	Yes
Click to dial	-	-	Yes
Inbound/outbound call handling	Yes	Yes	Yes
Phone call control	Yes	Yes	Yes
Configure phone preferences	Yes	Yes	Yes
Configure keyboard short cuts	Yes	Yes	Yes
CLI (ANI) / Name display	Yes	Yes	Yes
Speed dial / Busy Lamp Field management	Yes - 15 icons maximum.	Yes - 100 icons maximum per tab.	Yes - from Personal & System Directory
Speed Dial tabs (to group Busy Lamp Field icons)	Yes - 1 tab.	Yes - 10 tabs maximum.	-
Transfer call by drag and drop to a speed dial icon	-	Yes	-
View internal users' presence	Yes (Telephony + LCS ^[1])	Yes (Telephony + LCS ^[1])	Yes (Telephony ^[1])
Send Instant Messages (IM) to internal users	Yes (requires LCS ^[1])	Yes (requires LCS ^[1])	Yes
Telecommuter mode	-	Yes (not PC SoftPhone)	Yes (not in Office Worker profile)
Mobile Twinning Configuration	-	-	Yes
Call Pickup	-	-	Yes
Compact mode	-	Yes	-
Personal Phone Directory	-	Yes - 1000 entries maximum.	Yes - 100 entries maximum
System Phone Directory	-	Yes - 5000 entries maximum.	Yes - 5000 entries maximum
External Phone Directory (e.g. LDAP/Active Directory)	-	Yes - 5000 entries maximum.	Yes - unlimited
Call history log – all, missed, messages.	Yes – while logged in.	Yes– while logged in.	Yes - 24/7 call log
Separated incoming/outgoing call log.	-	Yes	Yes
Collect new voicemail messages.	Yes	Yes	Yes

Feature	Phone Manager Lite	Phone Manager Pro	one-X Portal for IP Office
Voicemail box control (Intuity and IP Office modes).	-	Yes	Yes
Personal Distribution List set up (Intuity mode)	-	Yes	-
Incoming call scripting.	-	Yes	-
Time on call.	-	Yes	Yes
Advice of Charge (ISDN service provider dependent)	Yes	Yes	-
Door opening control.	-	Yes	Yes
Queue monitoring.	-	Yes - 2 Queues	Yes
Conference Control Display.	Yes	Yes	Yes
Audio Conference Management	Yes	Yes	Yes
'Screen pop' contacts with Outlook	-	Yes	Yes (with Call Assistant)
Simple Outlook contact record creation.	-	Yes	-
Agent Mode.	-	Yes	-
Distinctive Ringing (WAV file).	-	Yes	-
Post Connect dial (sending DTMF while connected to another party).	Yes	Yes	-
VoIP mode (to run as an PC Softphone)	-	Optional license	Yes (with Power User and Teleworker licenses only)
Video Softphone	-	-	Yes (with Power User and Teleworker licenses only)

1. LCS: Microsoft Live Communications Server 2003

Chapter 10. Receptionist

10. Receptionist

SoftConsole is the PC based Windows Receptionist solution for IP Office. It can be purchased with the Receptionist user license.

SoftConsole has been designed to improve operator service by providing the operator with call information and available call actions to simplify call handling and give the appropriate response to the caller. With this easy to use software tool the operator can maintain visibility of the number and type of calls waiting and so ensure that clients are greeted in a professional manner. SoftConsole has a similar look and feel to the Phone Manger application and can be minimized in the Windows system tray when not in use, but will pop up on the screen when a call is received.

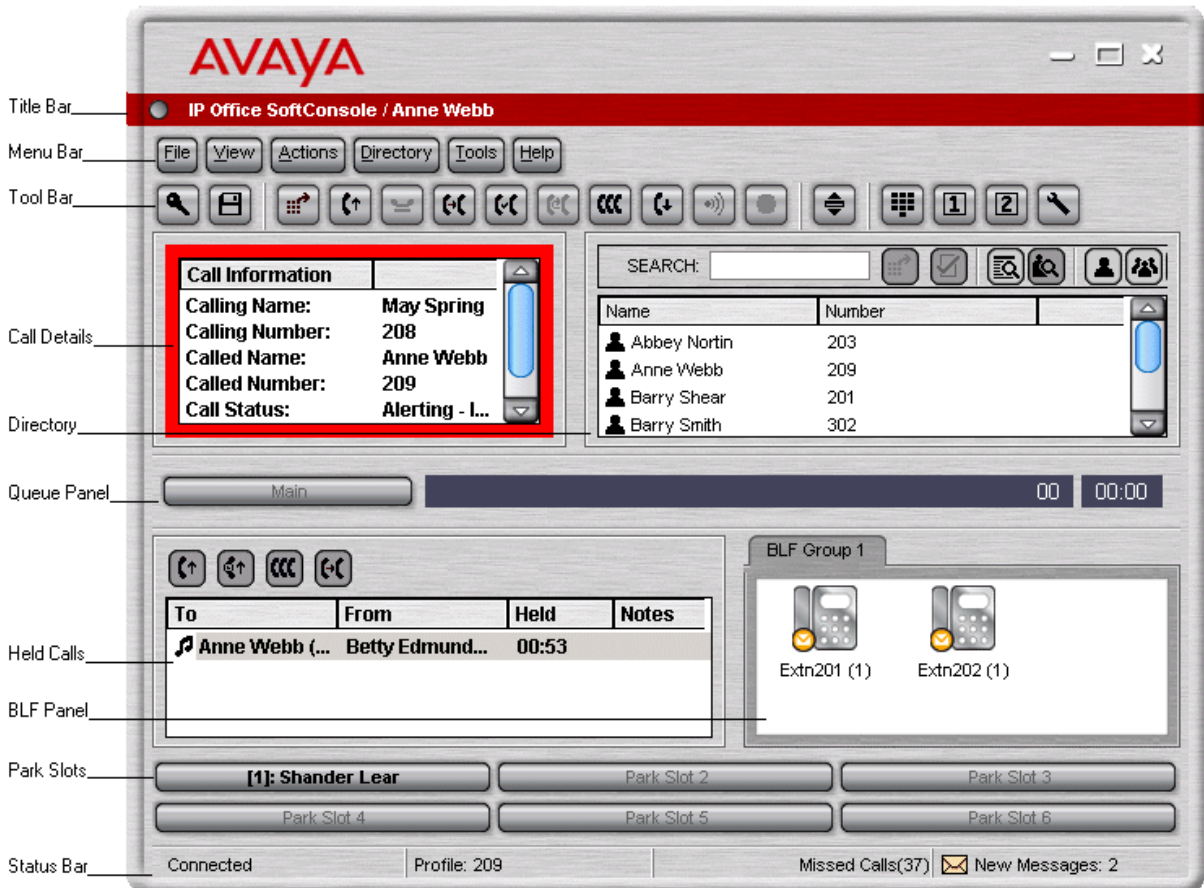

SoftConsole has been designed to be easy to use, while offering a look and feel, which will appeal to experienced and novice operators alike.

The SoftConsole screen is divided into the following areas:

- Main Menu Bar



Commands and actions are available through menus. Some features can only be used when the right conditions. If they are not available, the feature will be "grayed out" until conditions change that allow the feature to be used. The following features are available on the tool bar:

- Login.
- Save Profile.
- New call.
- Answer call.
- Hold call.
- Transfer call.
- Transfer complete.
- Reattempt transfer.
- Conference.
- Hang up.
- Page.
- Record call.
- Compact view.
- Dial Pad.
- Access conference room 1.
- Access conference room 2.
- Options.

- Call Details Panel

Call Information	
Calling Name:	Betty Edmunds
Calling Number:	204
Called Name:	Anne Webb
Called Number:	209
Call Status:	Alerting - Incoming
Duration:	00:02

The call details panel on the left shows details of the current call which will include the following information:

- **Calling Name**
The system directory name associated with the calling number.
- **Calling Number**
The telephone number of the call originator.
- **Called Name**
The system user name or hunt group name associated with the called number.
- **Called Number**
The extension number the incoming call has been routed to by the system.
- **Call Status**
States the progress of a call. The border around the call status panel changes color to indicate the status of the call.
- **Call Duration**
The length of time that the has been in the state as indicated by the Call Status
- **Notes**
This area displays notes or information about the call i.e. when a call has been returned as there was no answer from the extension it was transferred to. If annotation is attached to the call, details are shown in the Notes area.

If a new call arrives, the call details panel will display the calls waiting to alert the operator and allow answering of the call based on the Caller ID.

- Directory Panel

Property	Value
Name:	Anne Webb
Number:	209
Busy Status:	Idle
Do Not Disturb Status:	Off
Login Status:	Logged In
Group Status:	
Main	Out of Group
Sales	In Group
CustomerHelp	In Group
Absent Message:	
New Voice Mail Messages:	2
Forwarding Status:	
Forward Unconditional:	Off
Forward On No Answer:	Off
Forward On Busy:	Off
Follow Me:	Off
Forward Hunt Group Calls:	Off

The directory panel on the right shows information on following:

- Directory entries
Including IP Office users, hunt groups and external directory user (non IP Office extensions)
- Single directory entry details
Including IP Office users, hunt groups and external directory user (non IP Office user).
- Script
When a script has been configured for either the calling or called number, the script is displayed in this panel. For example, an operator may be answering calls on behalf of more than one company. To ensure the call is answered with the correct company name a script file can be created with the company name details. The script is displayed whenever a call is received for that company.

<table border="1"> <thead> <tr> <th colspan="2">Call Information</th> </tr> </thead> <tbody> <tr> <td>Calling Name:</td> <td>Company One</td> </tr> <tr> <td>Calling Number:</td> <td>01707364416</td> </tr> <tr> <td>Called Name:</td> <td>Anne Webb</td> </tr> <tr> <td>Called Number:</td> <td>209</td> </tr> <tr> <td>Call Status:</td> <td>Alerting - Incoming</td> </tr> <tr> <td>Duration:</td> <td>00:05</td> </tr> </tbody> </table>	Call Information		Calling Name:	Company One	Calling Number:	01707364416	Called Name:	Anne Webb	Called Number:	209	Call Status:	Alerting - Incoming	Duration:	00:05	<p>COMPANY ONE</p> <p>All calls are to be announced</p> <p>General Enquiries - Extension 123</p> <p style="text-align: right;">Close Script</p>
Call Information															
Calling Name:	Company One														
Calling Number:	01707364416														
Called Name:	Anne Webb														
Called Number:	209														
Call Status:	Alerting - Incoming														
Duration:	00:05														

- Conferencing
Within SoftConsole, calls can be conferenced when held, or a conference can be created through the two conference rooms:
 - Conference Held Calls
An operator can conference calls that are in the Held Panel. All calls in the Held Panel will be conferenced.
- Queue Panel
The queue panel displays a bar graph of the number and the status of external calls held in a particular queue. Up to 8 Call queues can be configured and labeled to reflect incoming calls for specific hunt groups.

Main		00	00:00
CustomerHelp		02	00:07

Queue Name: CustomerHelp
 Calls in Queue: 2
 Recall Calls: 0
 Status: Alarmed

- **Held Calls Panel**
The held call panel enables the operator to manage all calls held at the operator station. These calls will appear as a list in panel. The operator can perform the following the functions: Answer the highlighted held call, Answer the longest held call, Conference held calls (see conferencing section above) or Transfer held call.

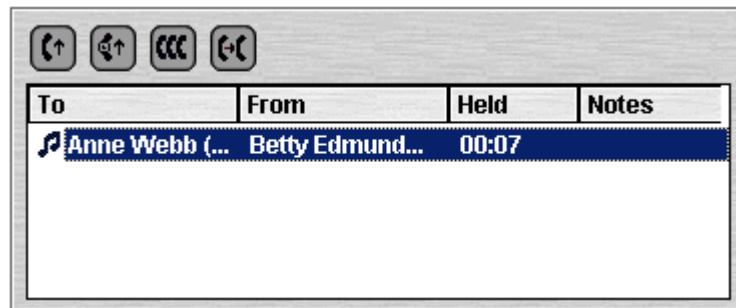

- **BLF Panel (Busy Lamp Field Panel)**
The BLF panel displays icons to indicate the status of selected users. Each icon provides information on individual users such as: Unread 'User' voicemail messages, User status information, for example Busy, DND and Forwarded is indicated by the various icons used. Up to 10 tabs with 100 icons on each tab are supported.

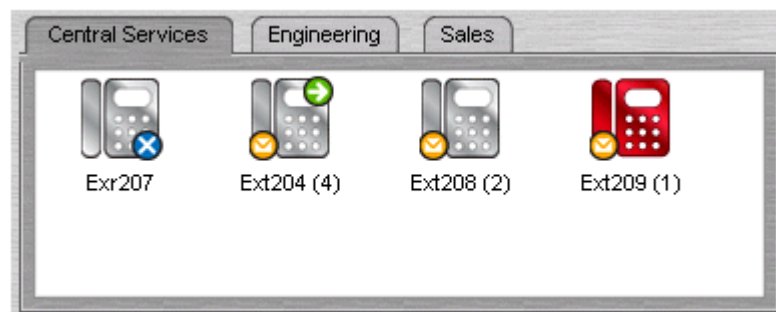

- Park Slot Panel
The park slot panel can contain up to 16 system-wide park slots with specific Park ID's for each slot.
- Call History
SoftConsole's call history keeps a combined record of up to 100 (incoming, outgoing and missed) calls while the application is active Double-clicking any logged call dials that number.

	Number	From	To	Tag	Date & Time
!	206	Theresa Green	Anne Webb		19/10/2006 15:12:01
!	210	Paul Jones	Anne Webb		19/10/2006 15:12:24
(209	Anne Webb	?Anne Webb		19/10/2006 15:12:50
(209	Anne Webb			19/10/2006 15:14:33
)	206	Theresa Green	Anne Webb		20/10/2006 08:53:50
!	206	Theresa Green	Anne Webb		20/10/2006 08:55:09
)	206	Theresa Green	Anne Webb		20/10/2006 08:56:07
(209	Anne Webb	May Spring		20/10/2006 09:06:28
!	210	Paul Jones	Anne Webb		20/10/2006 09:14:26

- Status Bar
This Shows current status of the system and is divided into four sections that display current connection status, current Profile name, information messages and The number of new voice mail messages for the operator. Information messages include any alarm conditions that are present within the system.

SoftConsole Options

SoftConsole has many configurable options available to the operator to personalize the look and feel. The Operator can tailor the usability specifically to each their personal preferences. The following configuration options are available:

- **Incoming Calls**
This tab enables the operator to manage the local SoftConsole directory by creating, editing and deleting entries from the selected directory. Also the operator is able to associate a script or media file with each specific entry.
- **Queue Mode**
This tab enables the operator to configure the queue window with up to 8 hunt group queues, which will include a recall queue. Queues can be created, edited and deleted while also providing the operator with the additional benefit of positioning them in the queue window in order of operator preference. Management by exception is used to monitor queue status by enabling the operator to set up various alarm thresholds such as the Number of calls in queue and Longest waiting call time. A WAV media file can be associated with an alarm for further customization.
- **Park Slots**
This tab enables the operator to define which park slots are accessible on a system wide basis up to a maximum of 16. The operator is also able to assign which numbers are used to access each park slot and where the slot appears in the park slot panel.
- **BLF Groups**
This tab allows the operator to create and edit BLF groups.
- **Door Entry**
This tab allows the operator to configure up to two door entries.
- **Directories**
This tab enables the operator to choose access to the following directories: SoftConsole local directory, IP Office system directory and Microsoft Outlook contacts. Once chosen, the operator is able to map fields to directory entries.
- **Conferencing**
This tab allows the operator to set up the names of the two conference rooms. The names will appear on the telephone displays of users in the conference room (maximum of 10 characters).
- **Keyboard Mapping**
This tab allows the operator to assign keyboard short cut keys for SoftConsole functions.
- **Keyboard Actions**
This tab allows the operator to specify the default action when alphabetic or numeric characters are pressed.
 - **Alphabetic Keystrokes:** Begin directory search or Open call annotation window
 - **Numeric Keystrokes:** Begin directory search or Open pop-up dial pad
- **Appearance**
This tab allows the operator to change the appearance of SoftConsole fonts, skins and the call information window color.
- **SoftConsole**
This tab allows the operator to save the changes made to the configuration of SoftConsole either automatically or manually to a local configuration file on the PC.

SoftConsole Administration

SoftConsole has an administration mode that enables the operator to configure the following settings:

- Control panel views
The BLF panel, call history panel, held calls panel and park slot panel can be hidden or made visible.
- Change the Administrator password
- Edit operator profiles
Each operator can have a personalized profile, which can be configured by the administrator.
- Create and modify templates
SoftConsole comes with three predefined templates, which can be modified, or new templates can be created.
- Specify the maximum length of call notes
IP Office supports a wide range of different telephone types. These have different display sizes so the operator can define the character length of messages sent to each user according to the type of phone they use.
- System Tray working
The application can be minimized and left running in the system tray so that it can pop on received calls.

SoftConsole Telephone Requirements

- SoftConsole provides extensive call management, but it still requires an IP Office telephone to provide the speech path. SoftConsole has been tested and is certified to work with all Avaya wired digital and IP phones that are listed in ["Telephones"](#) ⁵⁸ chapter.
- SoftConsole cannot be used with IP DECT 3700 Series telephones.

SoftConsole PC Requirements

- IP Office software release 2.0 or later.
- PC requirements:
 - Always refer to the latest Avaya SME Technical Tip or Technical Bulletin for any updated information with regard to Operating Systems, Service Packs or PC hardware.
 - Refer to Technical Specifications section of the Product Description for Operating System and Hardware requirements.
- A maximum of four SoftConsole applications can be run per system. An IP Office license controls the number of simultaneous SoftConsole users.
- SoftConsole requires a SoftConsole license for each user. This license is part of the IP Office Receptionist user license.

Chapter 11.

Computer Telephony

Integration

11. Computer Telephony Integration

Computer Telephony Integration (CTI) is about bridging the gap between the telephone system and business applications. On IP Office, this is achieved by use of the IP Office CTI Link, a CTI middleware product and Software Developers Kit.

On IP Office, CTI is delivered through adherence to open standards. This gives businesses access to a wide range of third-party solutions, addressing vertical markets, and designed to meet their requirements. For developers, migrating their offering from other platforms to IP Office is quick and easy, and the advanced CTI features IP Office offers makes it easy to demonstrate full integration, and more business benefits.

IP Office provides two levels of CTI interoperability: CTI Link Lite, which is free of charge, provides all the functionality required to support the vast majority of applications, including screen-popping, and many third-party products.

CTI Link Pro provides enhanced functionality, including the ability to control multiple telephones and gives access to advanced call center operation.

Because IP networking is integrated into the IP Office system, all CTI is done through the LAN. On many other systems, CTI is delivered by a physical connection between each handset and computer (first party CTI). This introduces additional points of failure, as well as relying on non-standard interfaces and handsets. On IP Office, all devices can be used with CTI.

CTI with IP Office

IP Office offers a significant CTI capability. Several interfaces are supported:

- TAPILink Lite.
 - TAPILink Pro.
 - TAPI -WAV driver.
 - DevLink Pro.
 - IP Office SMDR.
 - IP Office Software Development Kit.
-
- **TAPILink Lite**
Provides first-party CTI support for Microsoft TAPI 2.1 and TAPI 3.0, so each PC can control or monitor one handset device. The software components are supplied with the IP Office system on the User CD-Rom, and do not require a license key for use.
 - **TAPILink Pro**
Provides third-party CTI support for TAPI 2.1 and 3.0. These components are identical to their first-party equivalent; the presence of the CTI Link Pro RFA license key (which can be purchased in the usual way for products) enables this additional functionality.
 - **TAPI -WAV driver**
Provides software-based support for voice processing. The TAPI-WAV driver is for use with TAPI 2.1 only; for TAPI 3.0, IP Office supports the Media Service Provider (MSP) interface, defined by Microsoft in TAPI 3.0. This functionality will only work in conjunction with CTI Link Pro and also requires TAPI WAV licenses. Each license enables 4 ports of voice processing.
 - **DevLink Pro**
Provides a real-time event stream in addition to the SMDR interface provided in IP Office SMDR. The real-time event stream takes the form of a call record, which is issued whenever the state of any endpoint of a call changes (typically there are two end points on a call, but for some circumstances, such as conference calls, intruded calls there may be more).
 - **IP Office SMDR**
Provides an interface to obtain SMDR events. A comma-separated record is issued for each call, when the call is completed. This interface is designed for call accounting and call billing applications. IP Office SMDR is available free of charge, and distributed on the IP Office Admin CD-ROM. The IP Office SMDR can be output direct from the IP Office control unit to a designated IP address and port.
 - **Software Development Kit**
This toolkit is delivered on a single CD-Rom, containing the developer documentation for TAPILink Lite, TAPILink Pro, DevLink Lite and DevLink pro, as well as pre-compiled programs for exploring TAPI 2.1 and 3.0. In addition, example source code is included, making it easy for developers to become familiar with IP Office CTI interfaces.

TAPILink Lite (1st Party TAPI Support)

TAPILink Lite provides simple first-party CTI via Microsoft TAPI 2.1 and 3.0. Individual desktop PCs connected to the Local Area Network communicate with IP Office via an IP connection over the LAN. Each PC is capable of controlling one telephone device (see diagram below).

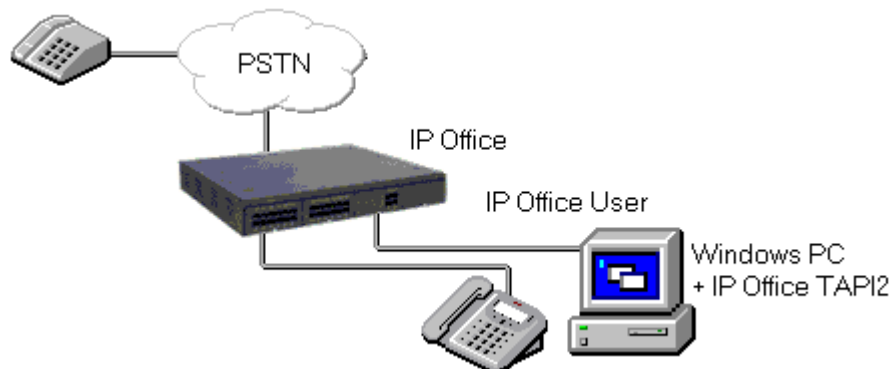

Microsoft TAPI 2.1 and 3.0 are specifications and developers interfaces for controlling and monitoring a telephony device. The specification requires that a certain amount of core functionality is implemented, and additionally defines a series of optional functionality that switch vendors may also implement.

TAPILink Pro (3rd Party TAPI Support)

TAPILink Pro provides all of the features and functionality of TAPILink Lite, but additionally provides third party CTI operation. This means that a single server can control and monitor any number of telephone devices.

In addition, TAPILink Pro provides the ability to monitor and control groups. This allows an application to be notified when a call enters a queue, and can also redirect it to another location.

TAPILink Pro also supports additional TAPI functionality that is not available through TAPILink Lite. This functionality is supported through the LineGetLineDevStatus and LineDevSpecific calls. The additional features are:

- Agent login.
- Agent logout.
- Set and retrieve divert destination.
- Set and retrieve extended divert status (Forward All Calls, Forward on Busy, Forward on No Answer, Do not Disturb).
- Retrieving the extension locale (language).
- Set and clear the message waiting lamp.
- Enable and disable group membership.
- Generate and detect DTMF digits and tones (requires the TAPI-WAV driver).

Support for Developers

The Developer Connection Program ("DevConnect") is the Avaya developer partner program, and is designed for third-party companies who are creating a product for sale, and who wish to receive technical support. Membership of the program is at the sole discretion of Avaya.

DeveloperConnect members pay an annual fee, for which they receive technical support directly from Avaya. In addition, Avaya will perform interoperability testing between IP Office and the member's product, and may also create opportunities for joint marketing, including exhibitions, use of Avaya's logo, and other benefits.

More information on the DeveloperConnect program can be found at www.devconnectprogram.com.

Chapter 12.

Messaging

12. Messaging

Messaging enables users to manage all of their messages, in particular emails and voicemails, in one place. Since the main messaging platform is typically email, IP Office Preferred Edition enables voicemails to be managed via the email system in order to keep all messages synchronized through one user interface. Essential Edition also enables some basic messaging through the ability to forward voicemail messages to the user's email inbox.

Voicemail in general provides a telephone answering machine with a personalized greeting on every employee's desk and allows callers to leave spoken messages when the user cannot answer a telephone call. Voicemail messages are retrieved either locally or remotely via any telephone (users are prompted for a PIN if they are using any telephone other than their allocated extension or a trusted location e.g. mobile telephone).

The voicemail server is multi-lingual and can offer different prompts depending on the user's preferred language, independently of the default system setup. Similarly, external callers can hear prompts in their own language depending on their incoming call route (e.g. based on caller ID).

Voicemail options available are:

- IP Office Essential Edition:
 - Embedded Voicemail
- IP Office Preferred Edition:
 - VoiceMail Pro – for single site use
 - Distributed VoiceMail Pro – for multi-site use in a Small Community Network (SCN)
 - Centralized INTUITY Audix / Modular Messaging Voicemail – for use with Avaya Communication Manager

Positioning Summary

For further details refer to [Voicemail Feature Comparison](#)^[259] at the end of this section.

Feature	Preferred Edition VoiceMail Pro	Essential Edition Embedded Voicemail
Supported IP Office Systems	PC Based All IP Office systems.	IP500 V2 IP500.
Mailboxes	IP Office automatically creates mailboxes for each user and hunt group on the system.	
Message Storage Capacity	1MB per minute up to hard disk capacity.	Up to 15 hours.
Maximum Simultaneous Calls	Up to 40 ^[1]	IP500 V2 = Up to 6 ^[2] IP500 = 4
Resilience and Backup	Yes	No
Small Community Network (SCN) centralized operation	Yes	No
Distributed Voicemails in an SCN	Yes	No
Voicemail to email forwarding	Yes	Yes
Unified Messaging (UMS)	Yes	No
Microsoft Exchange Server 2007 Integration	Yes	No
Centralized operation.	Yes.	No.
Queue Announcements	Yes.	Yes.
Auto Attendant	Yes.	Yes.
Call Recording	Yes.	No.
Intuity Emulation	Yes.	No.

1. Up to 40 in a single-site environment, additional ports can be added in a SCN environment by Distributed VoiceMail Pro.
2. The first two ports are included in the basic IP Office system price. Additional 4 ports can be purchased and licensed separately.

IP Office Essential Edition - Embedded Voicemail

In environments like retail or home office, where space, noise or cost considerations rule out using a PC for voicemail, Embedded Voicemail will be the favored option for an entry-level voicemail service. As built-in functionality of the IP500 and IP500 V2 hardware it requires no separate server. The Embedded Voicemail is enabled by purchasing the IP Office Essential Edition.

Key features of Embedded Voicemail include:

- Up to 6 ports of voicemail on IP500 V2.
 - IP500v2: the first 2 ports are included in the basic system, Up to four additional ports can be added simply by purchasing a license key.
 - IP500: max 4 ports of voicemail.
- Up to 15 hours message storage.
- Configurable recording time: Default value 2 minutes, maximum value 3 minutes.
- Mailbox security codes ensure a minimum of 4 characters to be set.
- Multiple languages stored on the flash memory card.
- Help menus via *4. Greetings and mailbox navigation.
- Send an email containing either notification or the complete voicemail message.
- Voicemail breakout/personal auto-attendant: Up to 3 breakout numbers can be set up. When callers are directed to your mailbox, they can either leave a message or choose to be transferred to one of three numbers (e.g. Operator, mobile/cell phone, colleague, etc).
- Configurable system-wide short code for voicemail collect (e.g. *17).
- 40 independent Auto Attendants with 3 time profiles per Auto Attendant.
- Up to 12 menu items per Auto Attendant with automatic time-out to fallback number.
- Auto attendant supports Dial by Name and direct Dial by Number (dial extension number without dialing access digit first).
- Access and control of voicemail via the digital or IP terminal display (Visual Voice). This feature is supported on the 1408, 1416, 1608, 1616, 2410, 2420, 4610, 4620, 4621, 4625, 5410, 5420, 5610, 5620, 5621 and 9600 series phones.
- Reply to a message to either an internal or external number (if Caller ID available).
- Support for hunt group announcements.
- Fax option for rerouting fax calls via the auto-attendant menu.
- Support for Fast Forward (#), Rewind (*), Skip Message (9) and Call Sender (**) when listening to messages.
- No license required.

IP Office Preferred Edition - Voicemail Pro

IP Office VoiceMail Pro is enabled by the IP Office Preferred Edition and is the most advanced messaging and call flow application for IP Office systems. It can handle up to 40 simultaneous calls depending on license and system settings. Each user has the option of turning their voicemail on or off. When on, the system automatically answers their telephone when they are not available to take a call, plays a personal greeting, and records a message.

When a message has been left, the user will see a message-waiting lamp lit on their telephone and can press a retrieval button to collect their messages.

VoiceMail Pro can also ring the user to deliver any new messages. Voicemail messages are time and date stamped and the caller's number recorded. VoiceMail Pro can be configured to delete read messages automatically, unless the user chooses to save the message permanently.

Vocemails can be collected remotely by dialing into the VoiceMail Pro server. If the number the user is dialing from is recognized (home number or mobile/cell phone for example), the user will listen to their voicemail straight away. If the source number is not recognized, the user will be prompted for a mailbox number and a PIN code for that mailbox, before they can listen to their voicemail. Users have the ability to set and change their own PIN codes.

When a voicemail needs to be forwarded to other users, VoiceMail Pro provides many options:

- Vocemails can be forwarded to another mailbox, or group of mailboxes
- Recipients can add their comments to the voicemail before forwarding to another mailbox or mailboxes.
- Vocemails can be forwarded as email WAV attachments.

All options are available in a choice of languages; both spoken voice prompts and graphical programming interfaces and have the choice of IP Office TUI and INTUITY emulation TUI.

Call Flows with VoiceMail Pro for Intelligent Call Handling

At the heart of VoiceMail Pro is the ability to construct call flows from a series of different building blocks. These building blocks allow automation over tasks like answer a call, listen for tone-dialed digits, make a call etc. VoiceMail Pro call flows allow far more than just guiding a user to the group or extension they require. Call flows allow VoiceMail Pro to dial back users as soon as a voicemail message is left for them, it provides remote access to phone forwarding settings should a user wish to change their Forwarding or Follow Me number from an external telephone. VoiceMail Pro provides message handling for individuals or groups, audio information to callers so assisting the operator during periods of heavy call activity and links to business applications through services such as Text-to-Speech. VoiceMail Pro provides a full telephony applications environment where call flows can be set up and interact in real time with business workflow – callers can interact via menus and data entry and VoiceMail Pro applications can speak back results. For example, users can listen to their email messages through the telephone.

Email Integration

Integration with email systems is provided by the VoiceMail Pro Unified Messaging Service (UMS) which is delivered to eligible users as part of the Office Worker, Teleworker or Power User license. It enables VoiceMail Pro to interact with email systems to provide a synchronization of vocemails and their status (new/unread, read, deleted, saved) between all user devices like desk phones, mobile cell phones, the UMS web interface, one-X Portal for IP Office, the email client and other devices that are synchronized with the user's email account. This will work for email clients that use the IMAP4 protocol (like MS Outlook, Lotus Notes, Mozilla Thunderbird, and many others).

VoiceMail Pro and Exchange Server 2007

Advanced collaboration between VoiceMail Pro and Microsoft Exchange Server 2007 offers voicemail storage into the Exchange message store. This is the single point of storage for all email and voicemail messages and therefore the single source for all message status information. When a voicemail should be collected using a desk phone connected to the IP Office, VoiceMail Pro will retrieve it directly from the Exchange message store. VoiceMail Pro sends the vocemails not just as emails with a .WAV attachment but as a message formatted as 'voicemail' so that Exchange can handle them differently from emails.

If Microsoft Exchange Server 2007 working with a mobility solution server (e.g., a Blackberry Enterprise Server) are used to push emails to mobile devices (Blackberry or similar), VoiceMail Pro will also integrate and deliver vocemails via the Exchange Server to the mobility solution. The mobile device will then be able to present vocemails on the visual voicemail interface (instead of presenting them as emails with an attachment).

Vocicemail in a Small Community Network (SCN)

A single PC based VoiceMail Pro server can provide voicemail services to multiple IP Office systems in a Small Community Network over the LAN, WAN or a Frame Relay network. This is referred to as 'Centralized Voicemail' and can reduce costs, while facilitating communication between IP Office sites. For resilience, should the main site fail, the Centralized Voicemail will automatically reconnect to an alternative IP Office site.

VoiceMail Pro - More than just Voicemail

VoiceMail Pro offers much more than just a pure voicemail system. Other helpful, convenient, cost and time saving options are:

- Whisper Announce that prompts callers for information (usually their name) which is recorded and passed on to the user's extension on answer, allowing them to choose to accept the call or not. This is particularly useful on "CLI/ANI withheld" numbers - usually calls from telesales companies where somebody is trying to sell you something. VoiceMail Pro will not intrude onto busy extensions.
- Assisted Transfer allows transfer of a call to a destination, but allows the call to return to VoiceMail Pro automatically for other options should the called party be engaged, or not answer within a pre-determined time.
- Conditional routing of calls. Conditions are constructed from a set of basic elements. These elements can be combined within a single condition to create complex rules. For example, the Week Planner can be used to define the company's standard working hours, and then combined with the calendar to define exception days such as public holidays / vacation.
- Call modules. Modules allow you to create sequences of actions that you want to share between a number of different call routing scenarios – like a "macro" in PC applications. These modules can be used to create a library of vertical voicemail applications or just easy dissemination to other IP Office voicemail sites, thanks to its import and export functionality.
- Activation of the external relays on the IP Office system. For example, remotely checking the status of the office heating and then turning it on from your mobile/cell phone on your drive in to work.

Key features of VoiceMail Pro include:

- Personal voice mailbox for users and hunt groups.
- Personal Numbering (follow me).
- Extended personal greetings to customize the information presented to a caller based upon the availability of a user.
- Unified Messaging (UMS) offers voice mail - email synchronization between the VoiceMail Pro server and the email client.
- UMS Web Access allows access to voice mails via a web interface from an internet browser.
- UMS integration of VoiceMail Pro with Microsoft Exchange 2007 Server for full message synchronization.
- Enables mobile messaging integration (e.g., Blackberry) when used with Exchange 2007 server integration.
- Forwarding of voicemail messages to email systems via SMTP.
- VoiceMail Pro client, a graphical user interface for programming and configuring applications both locally and remotely.
- Data base access via Interactive Voice Response (IVR) for individual business requirements.
- Audiotex and Auto Attendant services (including dial by name).
- Sophisticated queue announcement facilities.
- Access and control of voicemail via the digital or IP terminal display (Visual Voice).
- 22 supported prompt languages: Chinese (Mandarin), Danish, Dutch, English (UK), English (US), Finnish, French (France), French (Canadian), German, Greek, Hungarian, Japanese, Italian, Korean, Norwegian, Polish, Portuguese (European), Portuguese (Brazilian), Russian, Spanish (Castilian), Spanish (Latin American), Swedish.
- Conditions (e.g. test if 'out of hours').
- Broadcast group messages.
- Automatic and on demand call recording with an option for ContactStore search and replay of saved messages.
- Voice forms/questionnaire mailboxes (Campaign Manager).
- Personal distribution lists.
- Tag information retrieved from a database to a call and delivers it with the call to an agent.
- Visual Basic (VB) Script support to allow the configuration of the voicemail system through VB scripts rather than VoiceMail Pro call flows.
- Text-to-Speech facilities to allow emails to be read out over the telephone and/or for database information to be read to a caller in 14 languages.

- Housekeeping facilities for the management of messages.
- Automatic detection and routing of fax calls within Auto Attendants and within a subscriber's voicemail box.
- Support for a range of the INTUITY telephone user interface features in INTUITY emulation mode.
- Recording of system prompts through the telephone handset or using multimedia facilities on a PC.
- Speaking clock.
- Support for TTY hearing impaired text phone.
- Centralized VoiceMail within a multi-site IP Office environment.
- Networked Messaging with other Avaya voicemail systems.
- Capacity of up to 40 ports for a single-site system (depending on the IP Office control unit).
- Voicemail channels between VoiceMail Pro and the IP Office can be reserved for business critical functions or left unreserved for any function.
- Improved voice recording, including recording of calls made over IP endpoints (including those using direct media); automatic call recording triggered by incoming call routes; pausing recording when call is parked or placed on hold.
- User start points in VoiceMail Pro include queued and still queued options.

Further details on some of the VoiceMail Pro functionality listed above are described later in this section.

IP Office Preferred Edition - VoiceMail Pro Resilience and Backup

Customer service with uninterrupted access to the business is essential – for customers who want to place orders, for partners who want to negotiate an important contract and for employees who need access to their important messages. A failure can be very expensive for a business and there are a number of reasons why a failure can happen: power outage, lost network connection, cable cuts, hardware failure, and so on.

But loss of money and reputation does not necessarily have to follow such a failure. The IP Office Resilience and Backup functionalities are supported by VoiceMail Pro. A VoiceMail Pro server, connected to a Primary IP Office, can automatically re-connect to a Backup IP Office if the connection between the two IP Office systems gets lost. This covers the failure of an IP Office or the connection between them. A Preferred Edition license is required on the backup IP Office system for this scenario.

Introduced with Release 6, a Backup VoiceMail Pro server offers additional comprehensive functionalities to keep the business communication up and running. A Backup VoiceMail Pro server can be added to an IP Office / VoiceMail Pro system to take over the voicemail functions in the case of a failure at the primary VoiceMail Pro system.

The Backup VoiceMail Pro server can act in different scenarios:

- One IP Office, one Primary VoiceMail Pro server, and one Backup VoiceMail Pro server, where the backup is either at the same location as the IP Office / VoiceMail Pro or at an external site.
- A Primary IP Office with a Primary VoiceMail Pro server and a Backup IP Office with a Backup VoiceMail Pro server at a second location.
- A SCN with a Centralized VoiceMail Pro server connected to an IP Office at one site and a networked IP Office with a Backup VoiceMail Pro server. There might also be additional IP Office and Distributed VoiceMail systems within that SCN.

The diagram illustrates the second scenario:

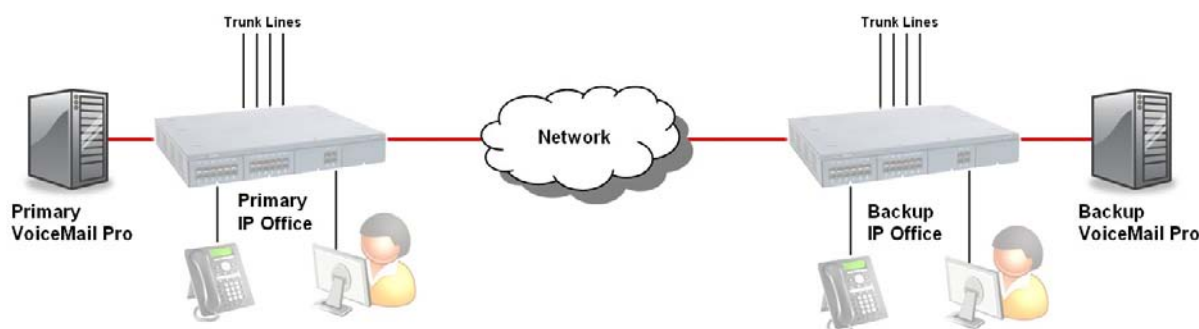

The Primary VoiceMail Pro will establish a link to the Backup VoiceMail Pro and keep the greetings and configuration setting changes synchronized with the Primary VoiceMail Pro. Messages and message states are not synchronized between the Primary and the Backup VoiceMail Pro to avoid network overload.

Ideally the Backup VoiceMail Pro server is a mirror system of the Primary VoiceMail Pro server with all its capabilities, like the number of ports, licensed features, and hardware. All required functions have to be licensed through IP Office Preferred Edition and supported by adequate hardware (e.g. to ensure server performance and sufficient IP Office trunk lines). The 2 hour run-time of a VoiceMail Pro server without licenses does not apply to a backup scenario.

The Backup VoiceMail Pro server can have limited functionalities (e.g. fewer number of ports) if it is acceptable to have limited capabilities for a limited period until the re-connection of the main server.

Distributed Messaging

One Centralized VoiceMail Pro server is supported in a SCN of multiple IP Office systems with IP Office / VoiceMail Pro release 5 and earlier. IP Office R6 allows multiple Distributed VoiceMail Pro servers to be placed at selected or all of the IP Office nodes.

Into one SCN there can be one Centralized VoiceMail Pro, one Backup VoiceMail Pro (as a backup for the Centralized VMPro), and up to 30 Distributed VoiceMail Pro (theoretical value). The Centralized VoiceMail Pro server will keep its role as the main voicemail server. It provides the media store for voicemails left on the system, as well as the media services required on the SCN to IP Offices not supported by a local VoiceMail Pro server.

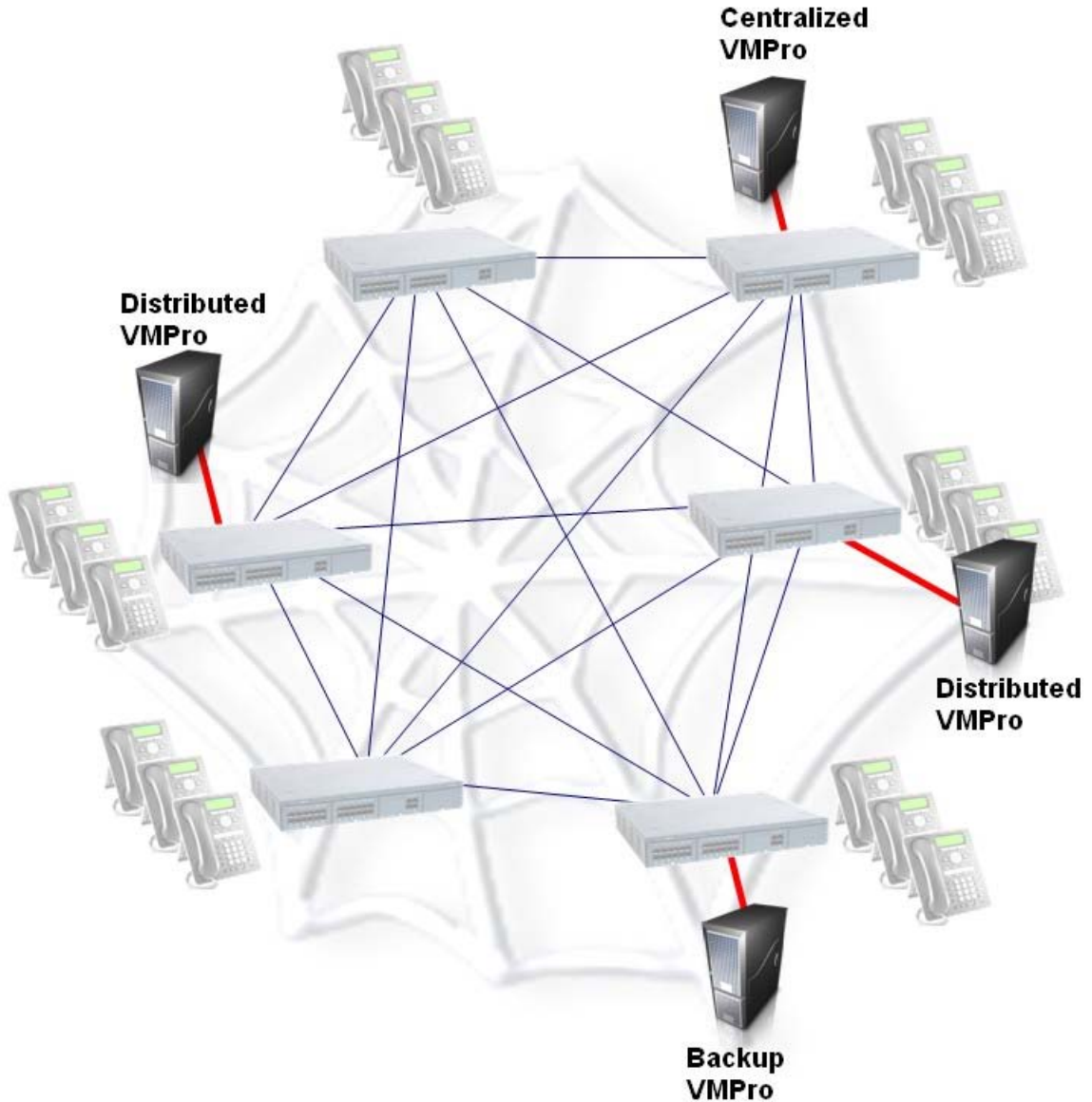

The retrieval of voicemails will require access to the Centralized VoiceMail Pro, while other voice resources will be available locally, providing local capabilities for queuing announcements, call recordings, auto attendants and leaving of voicemails.

On failure of a Distributed VoiceMail Pro, the Centralized VoiceMail Pro would be used for all functions as if no Distributed VoiceMail Pro servers were present.

There are no separate licenses for VoiceMail Pro, Distributed VoiceMail, Centralized VoiceMail, or Backup VoiceMail. These scenarios all require the same Preferred Edition license but will be configured differently in IP Office Manager according to the required function.

The screenshot shows the 'Voicemail' configuration tab in IP Office Manager. The 'Voicemail Type' dropdown menu is open, displaying the following options: <None>, Centralized Voicemail, Embedded Voicemail, Group Voicemail, Remote Audix Voicemail, Voicemail Pro (highlighted in blue), and Distributed Voicemail. A red arrow points from the dropdown menu to the 'Voicemail Type' field. Other configuration options visible include 'Voicemail Destination', 'Voicemail IP Address' (192 . 168 . 42 . 101), 'Backup Voicemail IP Address' (192 . 168 . 42 . 142), and 'Voicemail Channel Reservation' settings for Unreserved Channels (4), Auto-Attendant (0), Voice Recording (0), Mandatory Voice Recording (0), Announcements (0), and Mailbox Access (0). There is also a checkbox for 'Messages Button Goes To Visual Voice'.

Configuration of the different VoiceMail Pro options in IP Office Manager

Each central, distributed, or backup site requires at least a server with a Preferred Edition license. Other features, which should be distributed over the SCN, require suitable licensing, for example additional voicemail ports or the Advanced Edition (for IVR, ContactStore, VB Scripting and so on).

Interaction of Voicemail with Email Systems

As standard, VoiceMail Pro allows for a simple voicemail alert where the entire voicemail is forwarded (copied) as a .WAV attachment to any MAPI or SMTP compliant email application (Microsoft Outlook, Exchange, Lotus Notes, etc.). Forwarding allows emails and voicemail messages to be unified and collected from a single source. This simple alert option that forwards only the caller's number in the subject of the email is ideal for use with commercial Short Message Systems (SMS). This information can be forwarded to the display of a mobile/cell phone when the user is away from the desk. The email notification, forwarding and copying, can be done for all voice messages and can be activated remotely. This is beneficial if you are working from home and have an email connection available.

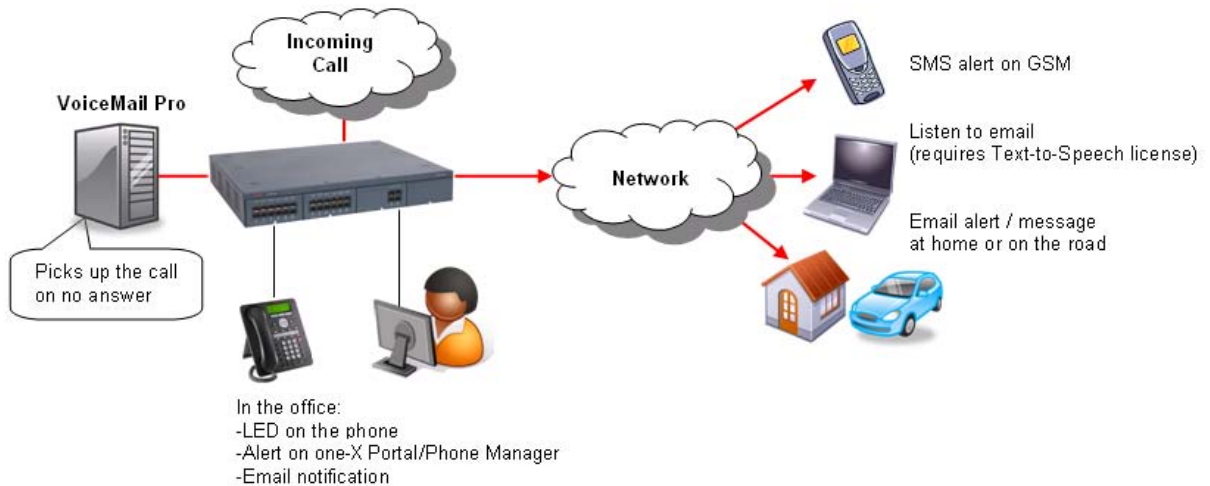

Forwarding voicemail to email is particularly useful for group voicemail boxes as it allows a single voicemail message to be copied to the email of every member in that group.

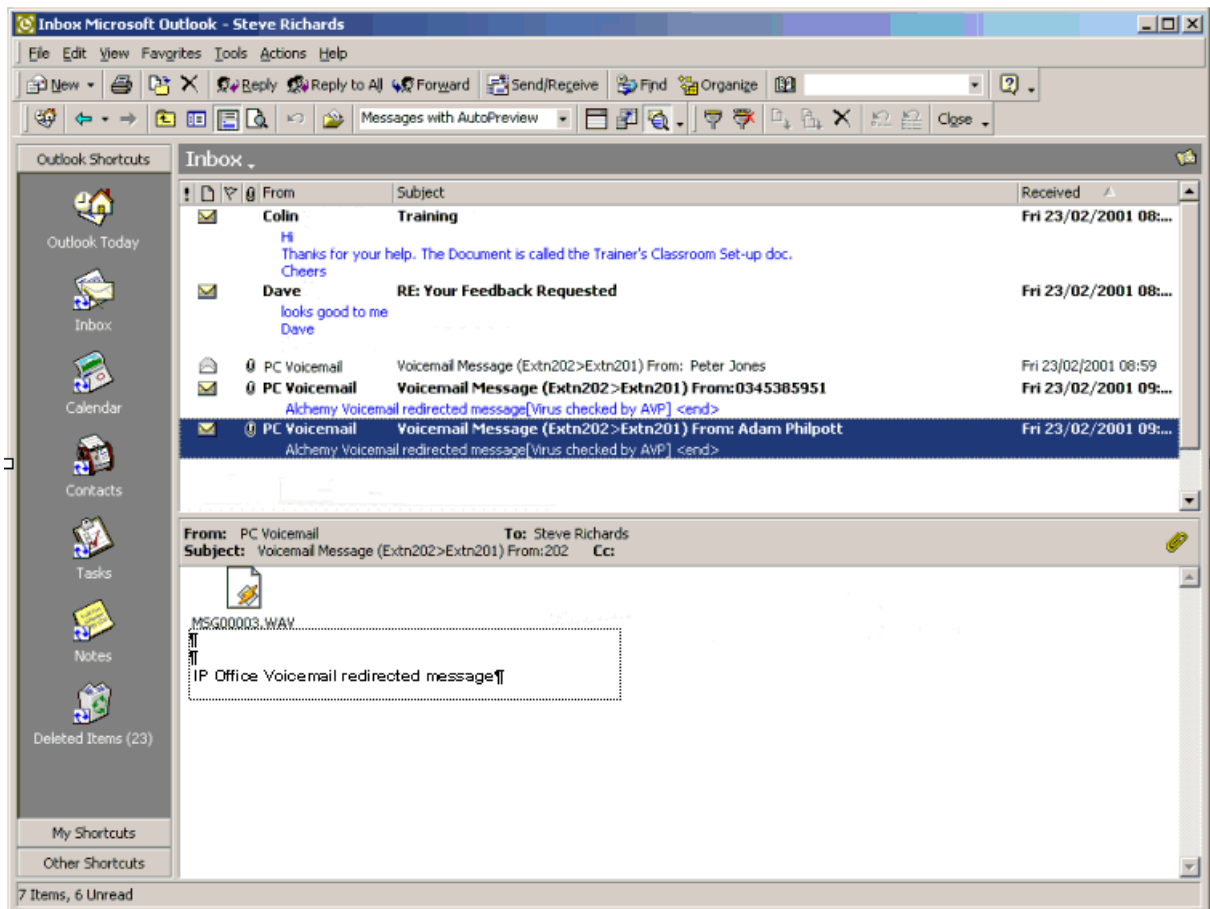

Presentation of Voicemail to Email

Unified Messaging Service (UMS)

Unified Messaging Service (UMS) provides the integration of VoiceMail Pro with email systems. A very simple installation and configuration process enables users to manage their voicemail messages by using the device of their choice including email clients or mobile devices. UMS is licensed on a per-user basis as part of the IP Office Power User, Teleworker and Office Worker.

Depending on the existing infrastructure UMS can be integrated with IMAP-based email solutions as well as with Microsoft Exchange Server 2007 environments.

VoiceMail Synchronization via IMAP

Email applications such as Outlook which support IMAP can connect to an IMAP server integrated with the VoiceMail Pro server.

VoiceMail Pro will deliver new voicemail messages by using the voicemail to email capability.

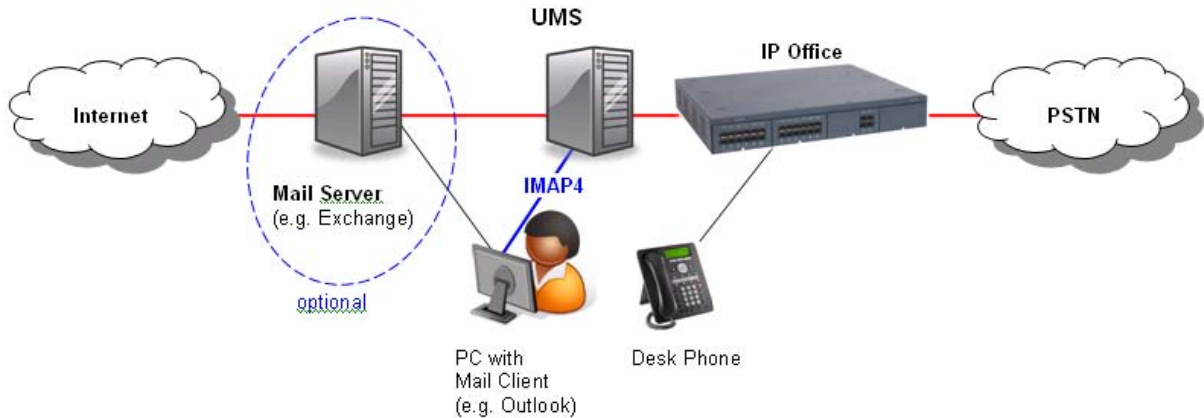

New voicemails arrive as emails with a .WAV attachment and the user can handle them like any other email. If a voicemail has been listened to, its status will change to "read", independent of the device that has been used to access the voicemail. If the user deletes it, it will be deleted everywhere.

Users that have UMS access enabled just need to add an additional email account to their email client to be able to use the unified messaging features. No additional client software installation is required.

The instructions how to add this account and configure the web address for the VoiceMail Pro Web Access can be provided by an administrator by email without the need for system administration or external support.

VoiceMail Pro UMS Web Access

The second interface UMS offers to the users is a web interface allowing voicemail access via a web browser, such as Internet Explorer or Mozilla Firefox, with the ability to listen to targeted voicemails by using either the PC's multimedia equipment or the desk phone.

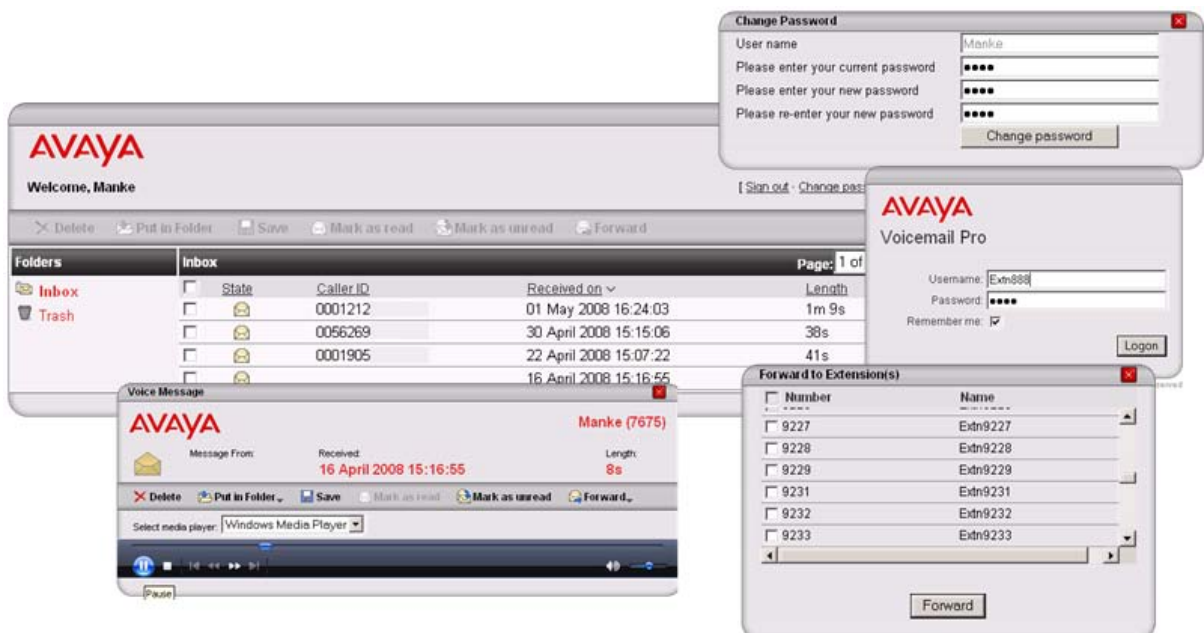

UMS Web Access requires the VoiceMail Pro installation to be on a server with IIS pre-installed. In addition, the VoiceMail Pro UMS Web Access option must be selected during installation.

Once installed, the system will require the following additional configuration:

- IP Office Power User licenses (for the number of users that will be configured to use UMS).
- Users selected for UMS support must be enabled by the system administrator in IP Office Manager.
- Each user must have a voicemail PIN code (a blank PIN is not acceptable).

Integration with Microsoft Exchange Server 2007

As part of UMS, VoiceMail Pro can integrate with the Exchange Server 2007 from Microsoft. Each user with UMS enabled can be configured to use either the IMAP capability (see above) or the Exchange integration. If the Exchange option is selected all voicemails of the user will be forwarded and stored into the Exchange 2007 message store instead of the VoiceMail Pro message store. VoiceMail Pro is able to deliver new voicemails to Exchange formatted as 'voicemail' which enables Exchange to handle them differently from standard emails. If used in combination with a mobility solution voicemails can be managed using the visual voicemail user interface of the mobile device (e.g. Blackberry).

The following diagram illustrates the two possible ways of integrating with either a standard IMAP-based email system or with an Exchange Server 2007 email system.

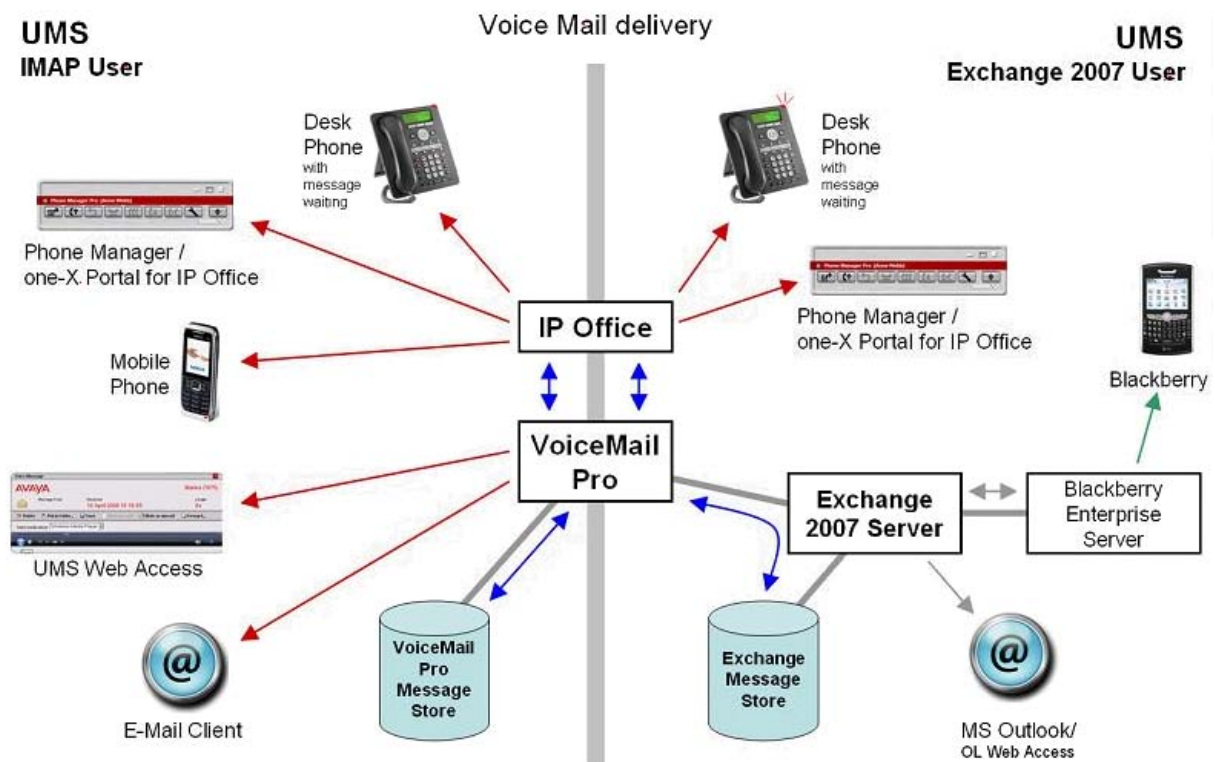

Both scenarios can exist in parallel on the same system but only one option can be configured for one user.

A voicemail stored in the Exchange message store can be retrieved by VoiceMail Pro and made accessible for all communication devices (as shown in the diagram above).

Earlier versions of Microsoft Exchange Server are supported by using the IMAP integration described above.

Fax Messages

Integration with fax software, integration with fax to the desktop or client fax applications can be realized through the use of fax servers. This allows an email client (for example Microsoft Outlook) to be utilized as an easily affordable unified messaging solution. The many benefits of unified messaging include security (as faxes are sent to the users PC rather than on paper for everyone to see), ease-of-use and efficiency in terms of storage and retrieval of messages and the great gains that can be made in overall workforce efficiency and productivity.

To enhance the support of third party fax solutions, VoiceMail Pro supports the automatic detection of incoming fax calls. Traditionally a dedicated telephone number is provided for all incoming fax calls. In addition to, or as an alternative to, the VoiceMail Pro 'Menu' action or a subscriber's voicemail box (INTUITY mode) can automatically detect any incoming fax calls and then direct the call to a predefined location. The benefit to a business or user is that only one number is required for either voice or fax calls.

The VoiceMail Pro can store the default fax location for the automatic routing of fax calls. Alternatively, with fax tone detection at the voicemail box, each voicemail box can have a fax location number. If a voicemail box owner has set his or her own fax number, then that number is used instead of the default fax location.

Voicemail box subscribers can set their own fax number through their mailbox menus.

Most fax solutions can be used in conjunction with IP Office; however the following products have been tested and verified to operate in the above scenarios:

- **Equisys - Zetafax**
Zetafax for Networks provides versatile network fax software solutions for small businesses, corporate offices and distributed enterprise businesses. It enables employees to send and receive faxes at their desktop, without the need to print fax communications, take them to a fax machine and send them manually. Zetafax can be seamlessly integrated into market leading email systems like Exchange allowing users to send and receive faxes directly from their Outlook client. In addition Zetafax can be integrated with other existing applications, such as accounting or CRM systems, for fast, automated faxing from the desktop or back office. Further product information available from www.equisys.com.
- **Open Text Fax Server (formerly Captaris – RightFax)**
RightFax offers a broad, scalable product line that integrates with email, desktop, CRM, ERP, document management, imaging, archival, call center, copier/scanner systems, as well as host, legacy and mainframe applications—virtually all business applications. Further product information available from www.captaris.com.
- **Fenestrae – Faxination**
Fenestrae Faxination Server for Microsoft Exchange integrates fax into email technology. Create faxes on your desktop and deliver them to your chosen fax machine at the click of a mouse. Further product information available from www.fenestrae.com.
- **GFI – GFI FaxMaker**
GFI FaxMaker for Exchange/SMTP allows users to send and receive faxes and SMS/text messages directly from their email client. It integrates with Active Directory and therefore does not require the administration of a separate fax user database. GFI FAXmaker integrates via the SMTP/POP3 protocol with Lotus Notes and any SMTP/POP3 server. Further product information available from www.gfi.com.
- **Open Text Fax Appliance (formerly Castelle FaxPress)**
Faxes routed to a user's mailbox by this fax server will be recognized by VoiceMail Pro as faxes, and will be supported by VoiceMail Pro Fax features. More information is available from www.castelle.com.

Text-to-Speech Email Reading (Microsoft Exchange only)

In addition to providing a unified mailbox for voicemail messages, emails and fax message, VoiceMail Pro can also provide the ability to retrieve email messages through the telephone.

When operating in INTUITY mode and with Power Users and/or Mobile Workers licensed these users will be presented with a list of both voicemail messages and email messages. The emails can then be read out over the telephone. The benefit to the user is that their messages are now accessible while in and out of the office through any telephone. The user's email account needs to be configured in IP Office manager to enable TTS functionality.

When accessing messages through the telephone all new voicemail messages will be presented to the mailbox owner before any new email messages. When accessing an email message the system refers to the message as *"New message with text"*.

Emails will be read based on the user language setting in IP Office, depending on the TTS engine capability. With no additional TTS engine installed VoiceMail Pro TTS will use the TTS engine installed with the Microsoft Windows operating system. If using Avaya TTS then 22 languages are supported. If using 3rd party TTS please refer to the vendor documentation for supported languages. Avaya TTS is an optional license.

Where the user has email reading in their voicemail box, they will be able to record a voice reply to the email, and send it as a .WAV attachment to a reply email to the person who sent the email.

A maximum of eight users can use TTS functionality simultaneously. If more than eight users are licensed and configured for TTS, the rule 'first come – first serve' will apply. In an SCN with a Centralized VoiceMail Pro the limit of eight concurrent TTS users for email reading will apply for the whole SCN because only the Centralized VoiceMail Pro delivers TTS. Therefore it is necessary to license at least one Power User or Mobile Worker at the central site (better will be four to eight users to provide sufficient resources for all users in the SCN).

Networked Messaging

Where organizations are operating a number of voicemail systems across different sites it is important to be able to provide integrated operation between voicemail systems so that messages can be passed between systems and delivered to a user's mailbox seamlessly. This is achieved by IP Office VoiceMail Pro being licensed to support Networked Messaging.

The Networked Messaging solution defines a common set of features to allow inter-working between Avaya voicemail systems. In INTUITY mode, while listening to or having listened to a message, the user can select the option to forward the message to another mailbox, the mailbox entered can be any mailbox number on the local system or any mailbox on a remote Avaya system.

The IP Office Networked Messaging facility will allow configuration of up to 2000 remote mailboxes on each VoiceMail Pro server and will operate with other IP Office systems supporting this feature, as well as with Avaya Enterprise solutions.

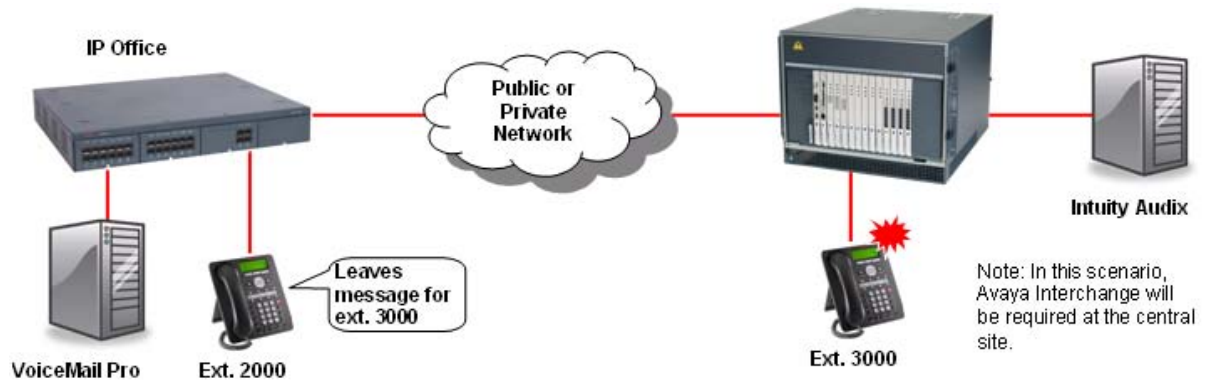

Auto Attendant

VoiceMail Pro provides an easy-to-use, multi-level configuration tool (the VoiceMail Pro client) which allows network managers and system administrators to construct an interactive menu system, based upon DTMF telephone key entry. This allows an Auto-Attendant system to be built and configured to suit business needs, be that on its own or as a back-up for the regular operator when call volumes are high. VoiceMail Pro offers the caller the ability to dial the name of a person via the phone keypad (like "Text" messaging on mobile cell phones). In response the Auto-Attendant offers the caller a best match name or if there is more than one, a selection list is offered and the caller can select which one they want to call.

As an example, VoiceMail Pro can be used to build an Auto-Attendant that prompts callers to "enter 1 for sales, 2 for support, 3 for admin, or 0 for the operator" allowing them to be transferred to the appropriate department without operator intervention. Alternatively, a list of personnel and their extension numbers could be listed, allowing the caller to directly access the person they want. For larger companies it could be department name listed first, followed by the list of employee extensions within the department.

The latter two examples are ideal where company telephone operation has changed from a central operator to direct dialing (DDI/DID), allowing callers to "learn" the required extension number from the prompting of VoiceMail Pro, and then in future dial the extension number, or other pre-defined variables, directly. Auto-Attendant operation is also ideal where multiple languages are required, for example "Dial 1 for English, 2 for German, 3 for French, ...".

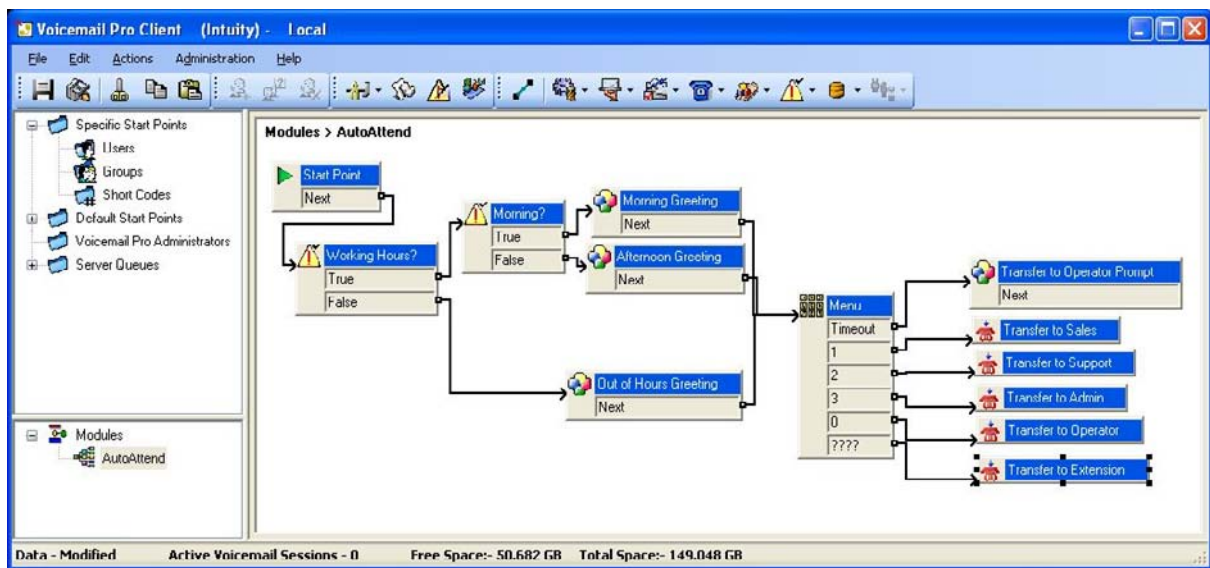

Auto-Attendant created using VoiceMail Pro Manager

Personal Numbering

Contact-ability is all-important in winning and maintaining business. VoiceMail Pro offers users the ability to remotely turn their voicemail on or off, set their voicemail email forwarding, edit their call forwarding and follow me numbers. Together these actions provide a comprehensive Personal Numbering service for the user who needs to remain in contact regardless of their physical location.

Users with Mobile Twinning configured are able to remotely activate their twinning capabilities through VoiceMail Pro call flow.

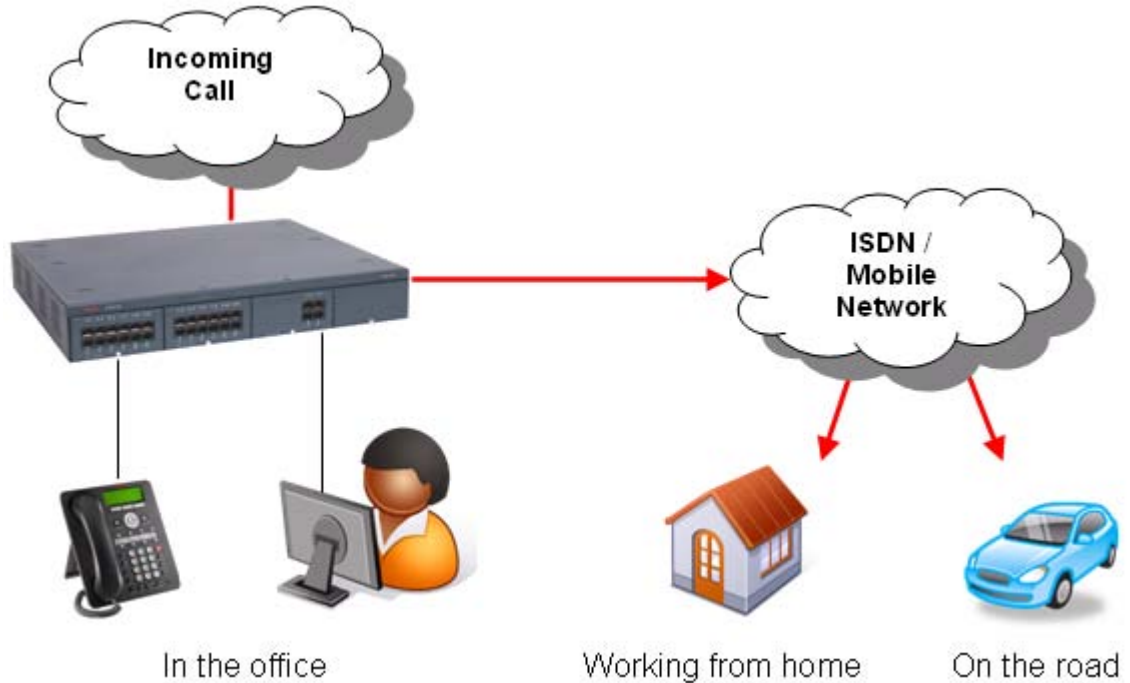

Diagram illustrating Personal Numbering

Accessing Database Information within Call Flows (IVR)

VoiceMail Pro provides the ability to construct powerful interactive systems based upon DTMF telephone key entry. This is achieved by using the flexibility provided from the built-in call flow actions. As a caller passes through any part of a defined call flow the system is capable of interacting with most third party databases using the standards based ADO interface (ActiveX Data Objects). The system is capable of retrieving information from a database and writing information into databases. The result of this is that powerful Interactive Voice Response systems (IVR) can be delivered to specifically meet the requirements of the business and the customer experience that is required.

Example interactive systems that can be built as a result of these facilities include: Information bulletin boards, order taking and order processing systems, front end systems to help desks/support desks, contact centers, secure access to information through PIN checking, survey systems, remote time sheet management, etc.

The ability to interact with database information is enabled through the purchase of the IP Office Advanced Edition. The VoiceMail Pro Client supports four Database Action Icons, which can be implemented into the VoiceMail Pro call flows. The entry of the IP Office Advanced Edition license will enable the VoiceMail Pro server to use these actions in call flows.

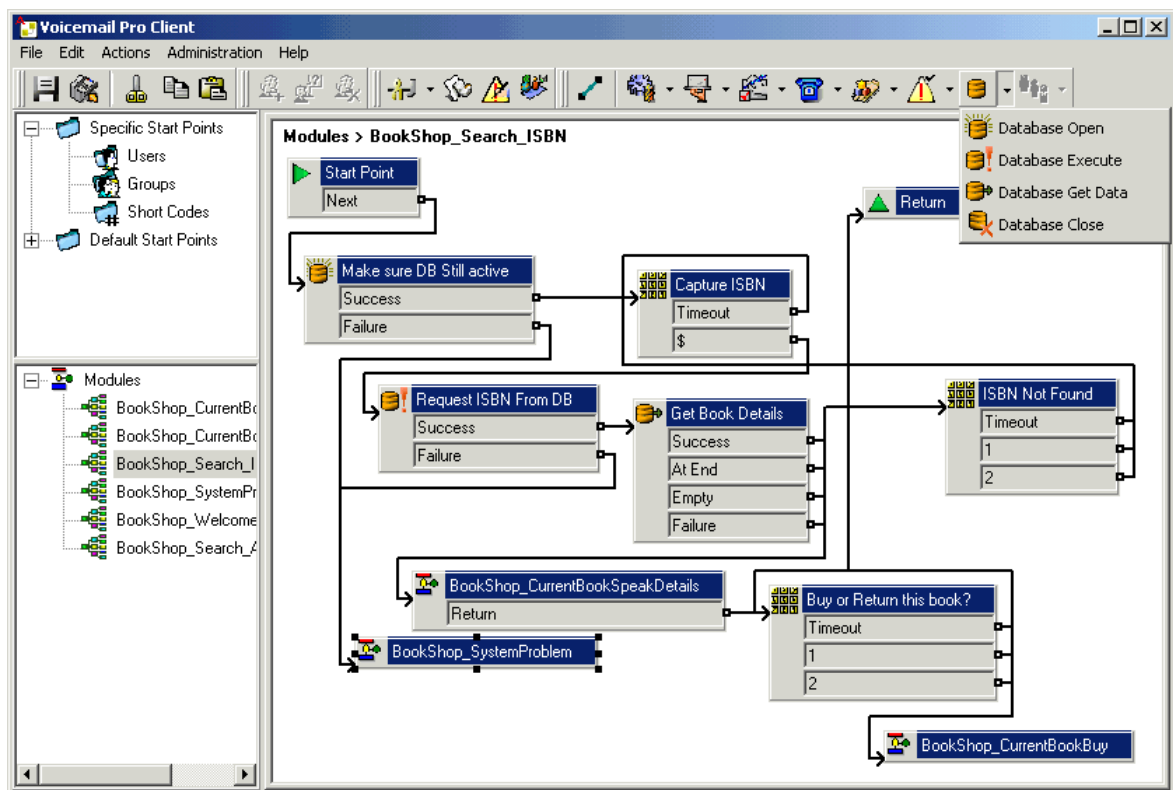

Example Call Flow Utilizing Database Actions

The database actions that are provided through the VoiceMail Pro Client are:

- Database Open – Opens a link to the required database. Multiple databases can be accessed during a call but only one database can be opened at one time.
- Database Execute – Provides the ability to enter a query on the opened database. The query can 'Select' data from the open database or can 'Insert' data into the database.
- Database Get Data – Provides access to the data that has been retrieved from a database through the Database Execute action. The user can retrieve the next item, previous item, first item in the list or the last item in the list.
- Database Close – This action will close the current database. If the database is open when a call terminates then the database will be automatically closed.

Interaction with the opened database is done through Structured Query Language scripts (SQL). An administrator can enter SQL script directly into the specific section of the Database Execute action. For administrators that are not familiar with SQL scripts, a script can be created automatically through the use of a SQL Query Builder Wizard.

Using Text To Speech (TTS) Facilities within a Call Flow

Text-to-Speech (TTS) can be used to further enhance IP Office IVR and call flow capabilities; TTS facilities can enhance the callers experience by allowing the system to read back to them any information that has been extracted from a database. For example, in a book shop, the caller dials into the system and is asked for an ISBN number of the book they require. The caller enters the ISBN through the telephone keypad and the system locates the title of the book from the database. As well as finding the title, the system could also look up the author of the book and whether there were any books in stock. By using TTS, the system could now respond to the call:

"The book, Lord Of The Rings, costing \$6.99, written by J R R Tolkien is in stock".

From VoiceMail Pro Release 6 onwards it is also possible to use Text-to-Speech within call flows or auto attendants for announcements. A call flow / auto attendant can be enabled to read text that has been created by call flow actions and offers much more flexibility because there is no longer the need for pre-recorded and static announcements. If there is a change to an announcement the call flow action will create the new announcement and will play it to the caller.

The IP Office Advanced Edition contains 8-port 3rd party Text-to-Speech capability and can be used either with a TTS engine that has to be purchased separately or - when no 3rd party engine is installed - with the Microsoft TTS engine which is part of the Windows operating system.

An alternative is the Avaya TTS license which adds a TTS engine available in 22 different languages:

- Chinese (Mandarin)
- Chinese (Cantonese)
- Danish
- Dutch
- English (UK)
- English (US)
- Finnish
- French (Standard)
- German
- Greek
- Japanese
- Italian
- Korean
- Norwegian
- Polish
- Portuguese
- Portuguese (Brazilian)
- Russian
- Spanish
- Spanish (Latin)
- Swedish

The Avaya TTS is a per-port license.

The total number of TTS ports on each VoiceMail Pro system is limited to eight. On a single or Centralized VoiceMail Pro, up to eight concurrent ports can be used for IVR and email reading, on a distributed VoiceMail Pro up to eight ports can be used for IVR.

Visual Basic (VB) Scripting

The VoiceMail Pro call flow programming interface allows an administrator to provide Visual Basic (VB) scripted logic that can be interpreted by the VoiceMail Pro server. This ability enables system administrators to program the voice system via VB Scripts thus providing additional choice and flexibility in providing IVR applications. The VB script action contains a VB-Scripting parser (Syntax checker) to ensure the legitimacy of the administrator derived VB Script before its incorporation. Each VB script action used within a call flow can contain a maximum of 10,000 characters; however a call flow may contain multiple VB script actions within it.

On a right mouse click in the VB Script window the methods and variables available will be listed to assist when constructing call flows.

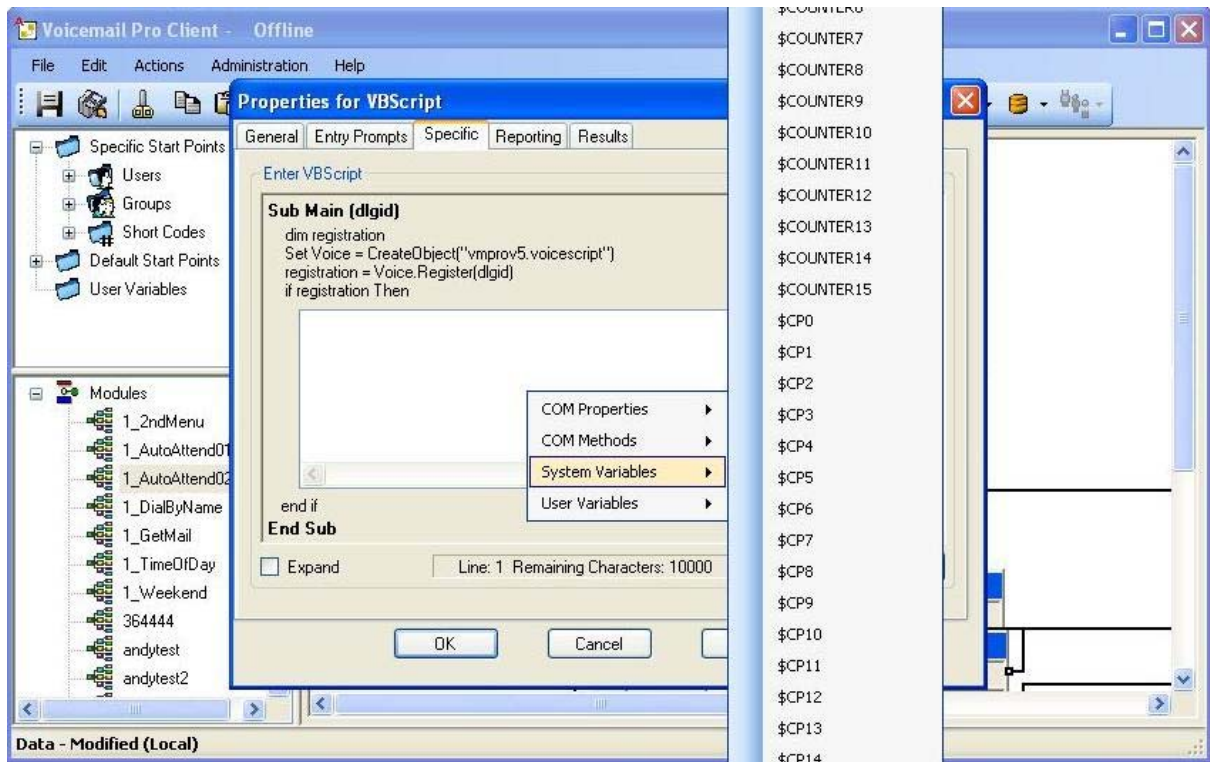

VB Scripting is enabled by the IP Office Advanced Edition license.

Extended Personal Greetings

In INTUITY emulation mode, the VoiceMail Pro system has the ability to hold a number of greetings within each user's mailbox that can be played to a caller. In addition to the standard mailbox greetings, the extended personal greetings provide the ability to present the caller with a greeting that reflects where the call has come from (internal or external) or why the called party is unable to take the call. A mailbox user can configure the responses played back to the caller, based upon the reason the caller was routed to the voicemail. The supported call states are:

- **Busy/Engaged**
The user is currently on a call and unable to accept a second call.
- **No Reply**
The user is away from the desk and unable to take a call.
- **Internal**
A greeting to be played to internal calls
- **External**
The greeting to be played to external callers
- **Out Of Hours**
The greeting played when a hunt group is operating 'out of hours'. Out of hours is defined with IP Office Manager and is only applicable to hunt group mailboxes.

A greeting can be recorded for each of the above conditions through the Telephone User Interface (TUI). If a recording is made for each condition, the order of play back to a caller will be:

1. Out of hours (Hunt group mailboxes only).
2. Internal/External greeting.
3. Busy/Engaged.
4. No reply.

A mailbox owner will need to record greetings against these conditions to deliver the greeting that they wish to present to a caller. one-X Portal for IP Office & Phone Manager Pro users can record and manage their voicemail greetings through the application GUI.

Hunt Group Broadcast Messages

With VoiceMail Pro, two modes of operation exist for the handling of hunt group messages. The method used is configured for the group through the IP Office Manager.

- **Hunt group mode**
Messages are stored in the hunt group mailbox and Message Waiting only informs those individuals configured for message waiting indication from that group. This is ideal for scenarios where only a few people such as a call center supervisor need to be initially aware of group messages. Any message waiting light lit by this is extinguished when the new hunt group message is accessed by a user. This is the default mode of operation.
- **Broadcast mode**
Messages are not stored in the hunt group mailbox. Instead they are broadcast (copied and forwarded) to the individual mailboxes of the entire hunt group membership. This lights the individual messages waiting light of each user of the hunt group until they access their mailbox.

Personal Distribution Lists

Personal Distribution Lists are only available with VoiceMail Pro when operating in INTUITY emulation mode. The feature provides the ability for a user to distribute a voicemail message to a list of recipients simultaneously. Lists can be configured by a voicemail box subscriber either through their voicemail box telephone user interface (TUI) or through the desktop PC application Phone Manager Pro.

The features available to a voicemail box subscriber include:

- Create up to 20 lists with 360 members per list
- Mark a list as private or public, Private lists can not be accessed by any other voicemail subscriber. Public lists can be used by other subscribers but can not be edited.
- Public lists can be copied from one subscriber to another by adding the contents into a new list.
- Subscribers can 'Create' new lists, 'Scan' contents of an existing list or 'Modify' existing lists.
- List members can be added by using the station number or mailbox name (names are not supported for VoiceMail Pro Networked Messaging mailboxes).
- Lists can include voicemail boxes that exist on other Avaya voicemail systems that are available through VoiceMail Pro Networked Messaging.
- Lists can be added together, duplicate members are automatically removed. This includes public lists owned by other voicemail subscribers.
- Mailing lists are accessible to the user at any 'send message' and 'forward message' option within the user's voicemail box.
- When displayed within Phone Manager Pro, distribution lists can have a list description added to it, this is only visible within Phone Manager Pro.

Cascaded Out-Calling

VoiceMail Pro can send a notification, with an escalation capability, that a new voice message has been received in a user's mailbox to specified phone number(s). This is particularly useful in environments such as healthcare and support where important voice messages are left and need to be answered promptly - even outside of office hours.

For example should a patient leave an important message to the main number of the doctor's office, the voicemail system can ring the doctor at the office then on no response escalates to the doctor's mobile/cell phone, his/her home phone or the doctor on duty after a programmable timeout. This avoids having to rely on an external answering service and allows mobile/cell and home phone numbers to remain private.

The voicemail notification can be sent for:

- Any new voice messages
- Any new priority voice messages

Mailbox owners can configure their own options from their handset (Telephone User Interface or TUI) and through their IP Office Phone Manager.

- Create own Time Profile – defining when notification should take place (e.g. office hours only)
- Out-calling destinations – defining where notification should take place and in which priority order

Five destinations can be defined by the mailbox owner through the TUI (Telephone User Interface). The destinations selected in the escalation list are called in sequence. The possible destinations are:

- Desk
- Mobile/Cell
- Home
- Delegate
- Other

Each time an outcall event occurs, each number in the escalation list will be called until either the call is answered, or the end of the list is reached. This process will be repeated on each retry attempt, for the number of retries set.

Out-calling preferences are set for global operation via the VoiceMail Pro Client. Out-calling is only available in INTUITY Mode. The administrator sets the number of retries and time interval between retries on a system-wide level.

Campaign Manager

As part of the IP Office Preferred Edition and VoiceMail Pro, Campaign Manager enables the gathering of repetitive information from inbound calls (such as brochure requests) to be fully automated, leaving agents free to deal with other more complex calls which require human interaction. A definable sequence of recordings are played to the caller with time in between each recording to allow the capture of the caller's spoken answers and/or the caller's key presses via DTMF. At the end of the transaction the caller can be thanked and the completed transaction retrieved by an agent via a web interface or a short code.

Campaign Manager allows calls in queue to break out of the queue, or be directed in an overflow situation to complete their transactions thereby increasing customer satisfaction by affecting an answer to their call. This ensures that a minimum of customers give up when forced to wait in a queue or even worse, hear a recorded message stating that they are calling outside of office hours.

In a Contact Center environment, when agents are busy, an overflow to Campaign Manager relieves congestion and pressure on agent groups. An agent can collect the completed transaction via a web browser or via a short code representing the park slot number of a particular campaign. This number can be pre-programmed under a DSS key and used by agents to access the campaign. If the DSS key incorporates a BLF lamp, that lamp is lit when new campaign messages have been left. Agents then transcribe the caller's answers into a database or other records.

Print

Test

Next New Next Active Next Processed

Ident	State	DateTime	CLI	Name	Brochure	Address
2	New	19/04/2004 14:02	203	00:02		
6	New	19/04/2004 14:10	203	00:04	00:04	00:02
a	New	19/04/2004 14:13	203	00:02	00:01	00:01

Submit Logout

Hold CTRL while selecting multiple qualifier Internet

Call Recording

IP Office Preferred Edition and VoiceMail Pro also offer call recording services that allow the automatic/manual recording of calls for a variety of applications, such as for training purposes or to monitor abusive callers. As standard, recordings can be directed to the called extension's voicemail box or to any other mailbox for later retrieval. Alternatively, recordings can be stored in a central database for retrieval through a Web based browser by using ContactStore for IP Office.

The system administrator can select whether all calls are required to be automatically recorded or just a selection of calls. Alternatively, calls can be manually selected for recording. If for any reasons resources are not available then a recording may not be taken (for example all voicemail ports are busy).

VoiceMail Pro provides a number of methods for triggering the recording of a call.

Most of the settings and controls for automatic voice recording are accessed through the IP Office Manager application. The proportion of incoming and/or outgoing calls that should be recorded and the time-period during which Voice Recording should operate can be selected.

- **User Recording**
The calls to and/or from a particular user can be automatically recorded. By default the recordings are placed in the user's mailbox
- **Hunt Group Recording**
The calls to a particular hunt group can be automatically recorded. By default the recordings are placed in the hunt group's mailbox, but there is the ability to select a target mailbox made for or on behalf of a subscriber.
- **Account Code Recording**
An account code can be applied to a call by the user before it is made. This can be used to trigger recording of outgoing calls.
- **Caller ID Recording**
Account codes can be assigned to a call by Caller ID matching. This allows recording to be based on a Caller ID match.
- **Time Profiles**
For each user, hunt group and/or account code, an IP Office time profile can be used to determine when auto-recording is used.
- **Incoming Call Routes**
Incoming Call Routes can trigger automatic call recording.

Note: It is possible for several recordings to be made of the same call. For example, if both automatic hunt group recording and automatic user recording are applicable to the same call, separate recordings are produced for both the hunt group and the user. Recording only continues while the party triggering the recording is part of the call, for example:

- Recording triggered by a user stops when that call is transferred to another user.
- Recording triggered by a hunt group continues if the call is transferred to another member of the same group.
- Recordings triggered by an incoming call route last until the call is cleared from the system.

Call recording uses the conference facility and so is subject to the conference restrictions of the IP Office system. For some situations, it may be a requirement that call parties are advised that their call is about to be recorded. This is done by switching on the Play Advice on Call Recording option via the VoiceMail Pro client. The maximum length of any call recording is 60 minutes.

IP Office ContactStore

The standard call recording facilities provided with IP Office and VoiceMail Pro can be extended further by using IP Office ContactStore. IP Office ContactStore stores and catalogs recordings so that they are easily accessible for later retrieval. Any recordings that you instruct VoiceMail Pro to "send to the Voice Recording Library" are placed in a database.

IP Office ContactStore is provided with the VoiceMail Pro software DVD set and has an inbuilt 45 day trial license. A fully featured IP Office ContactStore system can be installed and used for 45 days from the creation of the first recording. After this time the system will stop taking recordings until a license is purchased and installed onto the IP Office.

IP Office ContactStore has a number of components, these are:

- An MSDE database into which details of all recorded calls are inserted.
- A browser-based call search and replay application.
- A browser-based system configuration and status monitoring application.
- Disk space management - Oldest recordings are automatically deleted as needed.
- Optional archive management - Recordings are automatically written to a DVD +RW drive.

To allow you to search for calls easily, the details of the recordings are stored within a MSDE database. It contains one record for each call recorded and additional records for each party on the call and the owner of the call. The information that is held for any recording is:

- A unique reference for the recording
- The start date and time
- The duration of the recording
- The name and number of the parties on the call- where this was available to IP Office (through ANI, Caller ID or DNIS) at the time of the call.
- The direction of the call (incoming, outgoing, or internal)
- The owner of the call recording
- The target or dialed number, which may be different from the number that actually took the call.

Recordings within IP Office ContactStore are stored as .WAV files. IP Office ContactStore uses the G.726 16kbps ADPCM compression standard, which provides the best compromise between storage capacity and CPU loading. IP Office ContactStore is designed to perform compression as a background task, which does not impact the systems ability to record, search or play other calls. It takes approximately 1 minute to compress a two hour recording. The compressed recordings are stored as 16kbps G.726 format, storage requirements are therefore 8MBs per hour of recording.

The IP Office ContactStore suite can be installed onto the same server as VoiceMail Pro but must be loaded onto a separate partition. Alternatively, IP Office ContactStore can be installed on a separate drive within the same server or on a separate server. The minimum PC specification when VoiceMail Pro and IP Office ContactStore are installed on the same server is detailed in the Voicemail System requirements later in this chapter.

IP Office ContactStore stores recorded calls with certain security in place. Access to recordings is strictly controlled according to the security constraints configured within the System Administration pages. Each recording has an owner; the call owner is the number of the extension that recorded the call. You can specify to which extensions each user has replay rights; the user can search for and replay all calls "owned" by those stations. Typically an individual may be given rights to replay calls owned by their extension number while managers may have rights to the extension numbers of all of their staff.

The system will automatically generate alarms showing system warnings. Alarms are logged to IP Office ContactStore's database and held for a month before being purged. The administrator can define specific Email addresses for alarms to be automatically forwarded to. The email recipient could be a local system administrator, a manned help-desk and/or suppliers' support desks if you have a support agreement that includes this facility. The system sends an email message each time an alarm occurs or is cleared. It also sends an email once per day as a "heartbeat" to let you know it is still operating. Failure to receive the daily heartbeat message should be investigated; it could indicate that the server has failed.

IP Office ContactStore allows replay of recordings by means of a browser-based application that is accessible with Internet Explorer (IE) V6.0 and higher. The Search and Replay facilities include the following features:

- Personal security restrictions. The restrictions are applied as you log into the web server.
- Criteria-based search filter fields to perform specific searches.
- Replay controls. Use the replay controls to start, stop, pause, skip forward, skip backward, or to export the recording to a readily playable .wav file.
- Audio waveform display. The waveform presents a graphic representation of the audio content of the call. Use the waveform to avoid replaying static or silences, and to move easily to specific portions of a call.

The Search and Replay screen, shown below, provides filter fields that you can use to search for calls:

AVAYA ContactStore
powered by Verint Systems

02:14:30

Help | About
Change Password
Logout

Administration
[Administer System](#)

Search Filters

Call Start Range

01/04/09 00:00:00
13/05/09 23:59:59

Parties

Length

Target Number

Call Set

SEARCH

Results

Select All Select None

Call Start	Len	Parties	Type	Target	
24/04/09 02:13:54	00:15	2205 (Extn2205), 2207 (Extn2207)	Outgoing	2207	<input type="checkbox"/>
24/04/09 02:14:26	00:12	3103 (Extn3103), 2205 (Extn2205)	Incoming	2205	<input type="checkbox"/>
24/04/09 02:24:27	00:09	2205 (Extn2205), 2207 (Extn2207)	Outgoing	2207	<input type="checkbox"/>
24/04/09 02:25:19	00:12	3103 (Extn3103), 2205 (Extn2205)	Incoming	2205	<input type="checkbox"/>
28/04/09 00:37:53	00:05	2205 (Extn2205), 2207 (Extn2207)	Outgoing	2207	<input type="checkbox"/>

For a single IP Office, ContactStore is enabled by the Advanced Edition license. Note: For ContactStore to work for remote nodes across a Small Community Network (SCN) there needs to be a ContactStore license present on each node. This is in addition to the Voice Networking license required for SCN.

Centralized Messaging with Avaya Communication Manager

Where IP Office is deployed in an Avaya Communication Manager (ACM) Environment, it may be desirable to use one centrally managed voicemail system (INTUITY or Modular Messaging) to provide voicemail services to IP Office users. IP Office can be configured to use an INTUITY or Modular Messaging system over a remote connection such that all messaging calls divert to this location and message waiting indications are provided from the remote location and are displayed correctly on IP Office extensions. Connectivity must be either an E1 or T1 circuit or an IP trunk running QSIG services. In addition to the IP Office license Key (Centralized VM with ACM RFA) that enables this service, further license keys may be required on the ACM system.

Voicemail Feature Comparison

Platform Support

	IP Office Preferred Edition VoiceMail Pro	IP Office Essential Edition Embedded Voicemail
IP500 V2	Yes	Yes
IP500	Yes	Yes

Capacities

Voicemail	IP Office Preferred Edition VoiceMail Pro	IP Office Essential Edition Embedded Voicemail
Number of Mailboxes supported	No Limit - Limited only by IP Office configuration.	Limited only by IP Office configuration.
Maximum Number of Concurrent Calls (ports)	Up to 40 dependent on license	6 simultaneous calls on IP500 V2. 4 simultaneous calls on IP500.
Recording Time	PC dependent (Requires 1MB per minute)	15 hours.

Features

	IP Office Preferred Edition VoiceMail Pro	IP Office Essential Edition Embedded Voicemail
Runs as a service	Yes	No
Multi-lingual support	Yes	Yes
Voicemail for Individual users	Yes	Yes
Voicemail for Virtual users	Yes	Yes
Voicemail for Hunt Groups	Yes	Yes
Group Broadcast	Yes	No
Unified Messaging Service (UMS)	Option	No
Integration with Microsoft Exchange Server 2007	Option	No
Capable to interact with Blackberry solution	Option ^[1]	No
Resilience and Backup	Option	No
Small Community Network Operation	Yes	No
Centralized Voicemail Services	Yes	No
Distributed Voicemail Servers in an SCN	Yes	No
Voicemail Ringback	Internal and external	Internal only
Voicemail Help TUI	Yes	No
Message Waiting Indication	Yes	Yes
Visual Voice (interactive menu on phone display)	Yes	Yes
Integration with Phone Manager Pro	Yes	No
Personalized Greeting	Yes	Yes
Extended personal Greetings	Yes ^[2]	No
Continuous Loop Greeting	Yes	No
Forward to Email	Yes	Yes
Copy to Email	Yes	Yes
Listen To Email (Text To Speech)	Yes ^[2]	No
Send Email notification	Yes	Yes
Unified Messaging Service (UMS)	Option	No
Save Message	Yes	Yes
Delete Message	Yes	Yes
Forward Message to another Mailbox	Yes	Yes
Forward to Multiple Mailboxes	Yes	Yes
Forward with a Header Message	Yes	Yes
Repeat Message	Yes	Yes
Rewind Message	Yes	Yes
Fast Forward Message	Yes	Yes
Pause Message	Yes	No
Skip Message	Yes	Yes
LIFO/FIFO Message Playback Option	Yes	No
Set Message Priority	Yes ^[2]	No
Set automatic message deletion timeframe	Yes	No
Alphanumeric Data Collection	Yes ^[2]	No
Callers Caller ID, time and date announced	Yes	Yes
Call Back Sender (if Caller ID available)	Yes	Yes
Remote Access to Mailbox	Yes	Yes
User Definable PIN Code	Yes	Yes
Known Caller ID PIN Code By-Pass	Yes	Yes
Breakout to Reception	Internal and external.	Internal and external.

1. Requires UMS (enabled through the Power User, Office Worker and the Teleworker licenses) and MS Exchange Server 2007 with a mobility solution (for example a Blackberry) - not provided by Avaya.

2. Intuity mode only.

In-Queue Announcements

	IP Office Preferred Edition VoiceMail Pro	IP Office Essential Edition Embedded Voicemail
Queue Entry Announcement	Yes	Yes
Queue Update Announcement	Yes	Yes
Queue Position Announcement	Yes	No
Time in Queue Announcement	Yes	No
Time in System Announcement	Yes	No
Estimated Time to Answer (ETA)	Yes	No
Exit Queue to alternative answer point	Yes	No

Auto-Attendant/Audiotex

	IP Office Preferred Edition VoiceMail Pro	IP Office Essential Edition Embedded Voicemail
Multi-Level Tree Structure	Yes	Yes
Message Announcements	Yes	No
Whisper Announce	Yes	No
Alarm Calls	Yes	No
Assisted Transfers	Yes	No
Dial by Name	Yes	Yes
Direct Dial by Number	Yes	Yes

Other Features

	IP Office Preferred Edition VoiceMail Pro	IP Office Essential Edition Embedded Voicemail
Call Recording	Yes	No
Test Conditions	Yes	No
Personal Numbering	Yes	No
Speaking Clock	Yes	No
Campaign Manager	Yes	No
VoiceMail Pro Manager	Yes	No
Customized Voicemail	Yes	No
Intuity TUI emulation mode.	Yes	No
Forward Emails to External Systems (VPIM)	Yes	No
Third Party Database Access (IVR)	Yes	No
Text To Speech within call flows	Yes	No
Support for Visual Basic Scripts	Yes	No

IP Office VoiceMail Pro Intuity Audix Emulation Features

Voicemail Box Feature	Intuity Feature support	VoiceMail Pro support
Basic Commands		
*4 (or *H)	Help	Yes
*7 (or *R)	Return to main menu	Yes
*9 (or *W)	Wait	Yes
**6 (or **N)	Look up number/name	Yes
**9 (or **X)	Exit system	Yes
0 or *0	Transfer call to operator	Yes
*3 (or *D)	Delete	Yes
**8 (or **U)	Un-delete	Yes
**4 (or **H)	Hold message in category	Yes
*8 (or *T)	Transfer out	Yes
**7 (or **R)	Log in again	Yes
Options while listening to messages		
9	Increase speed	Not supported
8	Decrease speed	Not supported
4	Increase volume	Not supported
7	Decrease volume	Not supported
6	Skip forward	Yes
5	Skip backwards	Yes
*6	Skip to next message component	Yes
*5	Skip to previous message component	Yes
2 or (*2)	Rewind to start of message (skip to previous message)	Yes
3	Play back header after pressing 2	Yes
*1	Print fax or text	Available as an option but fax messages not currently supported
Options for addressing voicemails		
*2 (or *A)	Alternate between name and number addressing	Yes
*5 (or *L)	Use mailing list for addressing	Yes
Responding to a message		
0	Call the sender	Yes, provided Caller ID is provided.
1	Reply to the sender by voicemail	Yes
2	Forward with comment at beginning	Yes
3	Forward with comment at the end	Yes
4	Record and address a message	Yes
Main Feature Support		
1	Record/Send messages	Yes
2	Get messages	Yes
3	Create greetings	Yes
4	Outgoing and filed messages	Not supported
5	Personal Options	Support for options 1, 3-7.
6	Outcalling	Yes.
7	Autoscan/Autoprint	Autoscan supported

PC Requirements

General Requirements

- The IP Office Preferred Edition license enables a 4 port VoiceMail Pro and up to 8 ports 3rd party Text-to-Speech. To use the maximum of 8 TTS ports a minimum of 8 VoiceMail Pro ports is required. The TTS engine has to be purchased/licensed separately.
- Additional VoiceMail Pro ports can be added by purchasing the VoiceMail Pro 2, 4, 8 and 16 port add-on licenses up to the maximum depending on the IP Office System.
- The IP Office Advanced Edition license enables the following VoiceMail Pro components:
 - VB Scripting.
 - IVR.
 - Contact Store.
 - 3rd party Text-to-Speech, 8 ports (separate TTS engine required, or MS TTS engine delivered with the Windows operating system).
- If VoiceMail Pro server is installed without a license it will run for 2 hours and then shutdown. Not applicable to Backup VoiceMail Pro use.
- IP Office DVD contains VoiceMail Pro with its components.
- Switch off any PC and hard disk sleep, power down, suspend, hibernation modes.

PC Specification

- Always refer to the latest Avaya IP Office Technical Tip or Technical Bulletin for any updated information with regards to Operating Systems, Service Packs or PC hardware
- Refer to Technical Specifications section of the Product Description for Operating System and Hardware requirements

Network

- The Voicemail PC must be configured and tested for TCP/IP networking.
- The Voicemail PC must have a fixed IP address.

Disk Space

A compact or typical installation requires 500MB for the VoiceMail Pro software. A full installation requires up to 2GB of disk space. However prompts and recorded messages consume an additional 1MB of disk space per minute.

- For a busy environment you can expect to require at least 1,000 minutes of message recording space, that is 1GB.

Web Server Operation

If web browser access to Unified Messaging Services (UMS) Web Access and/or Campaigns is required, Microsoft IIS Web Server must be installed on the VoiceMail Pro PC before installing VoiceMail Pro. Both applications must run as a service. A server operating system is required for IIS.

UMS Client Requirement

UMS IMAP access requires IMAP4 capable email clients such as Outlook. For voicemail web access see Web Server Operation above.

Server PC Consolidation

The VoiceMail Pro server application with all its components can be installed on a single server PC together with the Avaya one-X Portal for IP Office server application and the customer Call Reporter application. For this scenario the following limits have to be considered:

- A maximum of eight VoiceMail Pro ports (with a maximum of four ports TTS)
- A maximum of 50 one-X Portal for IP Office users
- A maximum of 30 Customer Service Agents
- A maximum of 500 calls per hour

Voicemail to Email Connection

Voicemail to Email operation is supported using either MAPI or SMTP. MAPI requires the VoiceMail Pro server PC to have a MAPI compliant email client install. See Voicemail Email Integration.

If Text to Speech is installed, email text to speech is supported using MAPI.

In both cases above, full email sending from the server PC to users PC should be configured and tested before VoiceMail Pro installation using the same PC user account under VoiceMail Pro will be installed.

UMS Exchange Integration

A Microsoft Exchange Server 2007 is required. Earlier versions of Exchange can be integrated using the IMAP capability of UMS.

Voice Recording Library Management

IP Office Voice Recording Library (VRL) application is IP Office ContactStore. This application and its installation are documented separately. However:

- Avaya ContactStore for IP Office should be installed after VoiceMail Pro has been installed and its operation verified.
- The use of a DVD recorder for long-term archiving is recommended.
- A figure of 7.2MB per hour of archived recordings is given.
- The archived messages held by IP Office ContactStore are accessed via web browser using the port address 8888. This port address is not configurable and so it is necessary to ensure that it does not conflict with any other web server service running on the same server PC.

Chapter 13.

Mobility

13. Mobility

Sales or service reps who are always on the road know the challenges: missed calls, phone tag, languishing voice messages, delays in decision making and frustrated customers. Plus the real possibility of missed transactions and lost revenue. Equipped with Avaya IP Office Mobility Solutions, mobile associates never need to miss an important customer call or a question from someone in the office. And they'll be able to give customers just a single phone number — their office number — where they can be reached regardless of their location. Personal mobile phone numbers are never given out, but all calls ring simultaneously on their desk phones and their mobile phones. So if they are at their desks or on their mobile phones, they'll get the call. With IP Office Mobility Solutions they maintain the agility that gives them an edge over larger competitors. Decision-making will be speeded-up, quick responds to customers and colleagues are enabled, and the solutions will help to ensure that deals close with this real-time connection.

On-Site Mobility

IP Office offers different solution for users working mainly at the business campus but with the need to be accessible all over the site.

Avaya On-Site Wireless Phone Solutions

Avaya IP Office Wireless Solutions include DECT and Wi-Fi based wireless IP phones. These are solutions employees can use every day to work more effectively and be more responsive to customers - all while increasing revenues and keeping communication costs firmly under control. Also, Avaya IP Office Mobility Solutions integrate seamlessly with IP Office, enhancing each customer's investment. IP Office's in-building Mobility Solutions improve communication with staff who, because of the function they perform, are mobile within the workplace. Using wireless technology, such individuals may be instantly contactable, with many obvious benefits:

- The wireless telephone is carried in the pocket, so users are not tied to the desk in order to remain in contact.
- Users may be contacted instantly to ensure fast, accurate decision making and immediate response to problems through planned radio coverage with no blind spots.
- Once installed the solutions do not incur additional cost like mobile phones would do, allowing a tight budget control.

Wireless Solutions

IP Office supports the following wireless solutions:

- DECT R4, the new DECT based solution for IP Office. Running in a separate, reserved frequency range, this solution provides best in class voice quality and is totally interference free from other radio equipment. Details on this solution portfolio can be found in the chapter "Telephones" of this document.
- Avaya VoIP Wi-Fi Solution, leveraging the Wi-Fi data network, allow a single infrastructure for both voice and data traffic. Leveraging an existing, voice ready Wi-Fi network allows a cost efficient deployment of a converged wireless data and voice infrastructure using the 802.11a, b and g standard. The solution is offered worldwide in selected countries including North America, EU countries and selected others. For details on this solution please refer to the chapter "Telephones" of this document.

Remote Solutions

IP Office supports the following VPN remote phone solutions:

- VPN phone client on 4610SW, 4621SW, 5610SW, 5621SW and 9600 Series IP phones offered worldwide.

For further details about IP Office On-Site Mobility solutions please refer to the chapter [Telephones](#) ⁵⁸ of this document.

Twinning

Twinning allows a primary extension and a secondary number (internal extension or external number) to operate together as a single telephone, when a call is presented to the primary phone the secondary will ring. If the primary telephone does not ring, for example in Do Not Disturb, the secondary phone will not ring.

The following types of calls are eligible for twinning:

	Internal Twinning	Mobile (external) Twinning
Any internal call on a Call Appearance button	✓	✓
Internal or external calls transferred to the extension	✓	✓
Direct Dial calls to that extension	✓	✓
Hunt group calls	✓	✓
Calls forwarded from another extension	✓	✓
Line Appearance calls (configurable)	✓	✗
Bridged Appearance calls (configurable)	✓	✗
Coverage calls (configurable)	✓	✗
Automatic Intercom calls	✓	✗
Returning transferred, held or park calls	✓	✓*
Callback calls from the system (Transfer and Park Return)	✓	✗
Paging calls	✓	✗
Follow Me calls	✓	✗

*Requires IP500 BRI, PRI or SIP trunks and Mobile Call Control to be enabled for that user.

Internal Twinning



This is typically used in scenarios like workshops or warehouses where team supervisors may have a desk with a fixed phone but also have a wireless extension (e.g. DECT). When a call is made from either twinned phone, the call will appear to have come from the primary phone (when the secondary is an extension on the IP Office system). Other users of the system need not know that the supervisor has two different phones. The supervisor's Coverage Timer and No Answer Time are started for the call and if the call is not answered within that time, the call will be delivered to available coverage buttons (if applicable) and then Voicemail (if applicable).

The following features are supported with internal twinning

- Follow Me To
- Follow Me Here
- Forwarding
- Do Not Disturb (inc exceptions)
- Context less hunt group actions: Membership / Service Status / Fallback Group configuration
- Voicemail On / Off / Access
- Call Log (Central Call Log for T3 and 1400/1600/9600 phones only)
- Redial (Central Call Log for T3 and 1400/1600/9600 phones only)
- Personal Directory Entries (for T3 and 1400/1600/9600 phones only)

External Mobility

Mobility functions for employees working not from the office but mobile are enabled either by the IP Office Power User or the IP Office Mobile Worker license. The former Mobile Twinning / Mobility License will continue to work with all the features described below.

The mobility functions enabled by these user licenses are Mobile Twinning, and Mobile Call Control, as well as one-X Mobile client support. Each feature has to be enabled in IP Office Manager for eligible users.

Mobile Twinning (External Twinning)



A typical use for Mobile Twinning would be for a salesperson that has a desk extension but is often out of the office. They only give out their office phone number to clients, but the IP Office Mobile Twinning will ring their mobile/cell phone as well as the desk extension. External mobile devices can be set as twinning targets even if the primary telephone is logged out (e.g. in the case of a "virtual" extension).

Call Back



To avoid any call charges when using a mobile / cell phone the call back feature has been implemented:

When calling a particular number at the IP Office, the IP Office will reject the call and will call back the mobile number if this number has been identified as an eligible one. After accepting this call the mobile user gets a dial tone and can establish another call. Depending on the service provider's tariff, there are no call charges (except possible roaming charges) on the mobile invoice.

This feature is very useful for employees using their personal mobile phone for business only from time to time: their personal mobile phone number stays confidential and they do not to claim mobile charges back from their business.

Avaya one-X Mobile Client Support



IP Office supports the Avaya one-X Mobile 'Single Mode' Clients running on selected Symbian Single-Mode or Windows Mobile 5 or 6.x handsets. This provides a graphical interface for call control and allows a one-number service for both incoming and outgoing calls.

For a full list of supported handsets see <http://support.avaya.com>.

IP Office systems supporting one-X Mobile require a dedicated DID/DDI number for each feature required (e.g. hold, transfer).

Mobile Call Control



This allows a user who has answered a twinned call on their mobile/cell phone to dial a DTMF sequence ** (star-star) to put the call on hold and receive IP Office system dial tone. The user will then be able to perform supervised and un-supervised transfers, shuttle (switch between held calls), and conference (Conference add and transfer to a meet-me conference).

Mobile Call Control is a mobility feature similar to but independent of one-X Mobile. It allows any mobile phone user to access IP Office features without using the one-X Mobile client application.

Mobile users can gain access to the "Star Star Service" dial tone when they receive a twinned call. After receiving a twinned call, the mobile user can dial ** to place that call on hold and get dial tone from the IP Office. Once the mobile user receives IP Office dial tone, any subsequent dialing done is interpreted as if the user is logged into an analog extension on the IP Office.

To gain access to the "Star Star Service" dial tone, the mobile user can dial the FNE 31 DID/DDI that has been programmed in the IP Office. Similarly, once dial tone is heard, the user can dial numbers and short codes as if the user is logged into an analog extension on the IP Office.

Mobile Call Control and one-X Mobile require twinned calls to be routed through specific trunk types on IP500 / IP500v2 only:

- IP500 PRI-U (single or dual) daughter cards
- IP500 Dual or Quad BRI daughter cards
- SIP trunks (RFC 2833)

IP Office Softphone



Usable both inside the office and at remote locations, IP Office Softphone is a PC-based telephony client allowing a user to make and receive phone calls right from his PC, equipped with e.g. a headset or speakerphone. In addition, the softphone supports end to end Video between two softphone users on a IP Office network. Full voice access to the IP Office system is available wherever reliable access to the company network exists.

This can be in meeting rooms, using a Voice ready Wi-Fi network, at a remote office site using the local Ethernet interface or at home or in a hotel-room, when connecting to the company network through a VPN (Virtual Private Network).

The softphone offers standard calling functionality, like several call appearances, hold, transfer and access to a large number of IP Office features via dedicated feature keys. Access to IP Office directory is of course also available.

IP Office Softphone can be used as a standalone client (not requiring any additional server) or in combination with one-X Portal for IP Office.

If used in combination with the one-X Portal application, the softphone delivers a centralized call log, synchronized with many IP Office telephones as well as a number of collaboration features like presence status indication and instant messaging. one-X Portal can be used with the standard deskphone while working in the office and switched to softphone when working remote.

Details about IP Office Softphone can be found in the chapter [User Call Control Applications](#)²⁰².

Mobile Messaging



Mobile Messaging means managing your voice messages together with email messages using the mobile / cell phone. Similar to a unified messaging solution on the desktop PC it enables the user to manage all of their daily messages in one place, in this case the mobile messaging application of the mobile / cell phone (like for example Outlook Mobile on Windows Mobile devices).

At the low end of the range of mobile messaging options is the simple voicemail-to-email forwarding using SMTP, which is standard with both the Essential and Preferred Edition.

The synchronization of the voice message status between all a user's devices (Outlook, voicemail telephone interface, one-X Portal, mobile / cell phone) so that listening to a new message at one device changes the message status from "new" to "old" in all of these interfaces requires the Preferred Edition. It contains an IMAP interface to integrate the VoiceMail Pro solution with any IMAP capable email system.

With the IP Office Preferred Edition in conjunction with an Exchange 2007 Server it is possible to synchronize received voice mails with the email system. If the email system also empowers mobile users to receive, manage, and send messages by their mobile phone ('Mobile Email') all voice mails can be managed as well from the mobile / cell phone.

Together with an appropriate mobility solution like Blackberry the Exchange 2007 integration enables visual voicemail on mobile devices. The voice mails provided by the Preferred Edition are specially marked as "voicemail" so Exchange 2007 handles them different from standard emails so that a mobility solution will be able to show voice mails on the display of the mobile device. Users can now browse through the voicemails, identify high priority ones by caller information and listen to them first.

3rd Party Mobility Solutions for Use with IP Office



Although Avaya offers different mobility solutions as mentioned above there are areas for further improvement. Together with Avaya DevConnect partners Avaya is anxious to further extend the usability and functionality of the IP Office system.

The following mobility solutions in particular add mobile devices currently not supported by Avaya for the IP Office so that users with one of these devices can participate from the rich IP Office mobility options.

Apple iPhone – iEC5xx



As the iPhone from Apple is increasingly used for business use, Avaya has enabled an available DevConnect solution to extend IP Office mobility also to this popular device. The application for the iPhone is called 'iEC5xx' and acts like the Avaya one-X Mobile clients. The same configuration file that is been used to configure the Avaya clients enables the mobility functions at the iPhone.

The application is available at the Apple App Store.

For more information see <http://elinfierno.de/apps/iec5xx/>



Blackberry – SoLo DTMF Client



One of the most used mobile business devices is the RIM Blackberry. To use a Blackberry with similar functions like the Avaya one-X Mobile application, the solution called "SoLo DTMF client" from SoSoftware enables selected Blackberry devices to use the IP Office mobility functions.

For more information and placing orders see <http://www.sosoftware.com/solo-mobile-dtmf>

These 3rd party solutions have the same requirements as the Avaya mobility options. Each user who wants to use one of the solutions requires at least one Power User or Mobile Worker license. In addition, at least a Preferred Edition might be required.

Chapter 14.

Audio Conferencing

14. Audio Conferencing

A problem familiar to any organization is that of communicating effectively. As more and more people work from home or from dispersed locations, how do you ensure that employees are planning and working together effectively, and regularly keeping in touch when separated by time and distance? In addition, many companies choose to sub-contract some services such as payroll, logistics or manufacturing to third-party suppliers. How do you ensure that you can act as one virtual enterprise? Audio conferencing provides a simple and effective solution.

Audio conferencing makes it easy to include key people in decision making wherever they are with minimum interruption from their work. It responds to business needs that every company faces:

- More meetings but less time available.
- Increasing pressure to be at two locations at once.
- Travel restrictions.
- Environmental pressures ("green" initiatives).

As a result of using conferencing, the benefits gained are:

- Reduction in travel, leading to lower costs, less wasted time and lower carbon emissions.
- Increased worker productivity and personal security.
- More effective working practices, leading to shorter project times, and supporting dispersed organizations and complex supply chains.

Furthermore, the Return On Investment (ROI) is very short as Meet Me conferencing is a built-in feature of IP Office Preferred Edition. The typical ROI of just 4 to 6 months compared to Service Provider conferencing services based upon 2 hourly conferences with 5 participants per week.

IP Office Preferred Edition Meet-Me Conferencing Solution

The conferencing solution built-in to IP Office enables multiple callers to talk in an audio conference. Callers can be on-site personnel as well as external parties whether field-based engineers, sales staff on the road, customers or suppliers. Conference calls can be planned in advance or established ad-hoc as and when required.

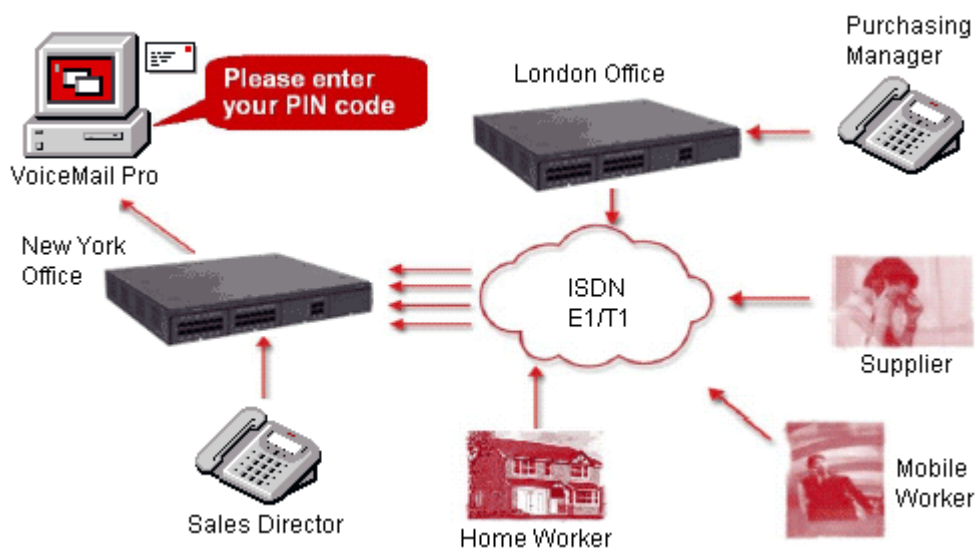

IP Office Preferred Edition with VoiceMail Pro complements the built-in conference bridge facility on IP Office systems by allowing participants to enter conferences through dedicated numbers, adding guidance prompts as well as requesting PIN codes as participants enter the conference for security. For example, if conference calls are regularly scheduled, VoiceMail Pro can have pre-programmed Call Flows for weekly conference calls e.g. every Tuesday between 2pm and 5pm using PIN code 1234 for a sales call, etc. If multiple conference calls are scheduled, users can select which one they want to attend via a simple menu. Should users encounter any issues, calls can be automatically routed to the operator for assistance. For additional security, if Caller ID information is provided by the network VoiceMail Pro can make CallerID checks before allowing calls into a conference.

IP Office Conferencing Capacity

IP Office provides a flexible conferencing solution with 28 conferencing channels on the IP500 and IP500 V2, allowing multiple conferences of any size from 3 to 64 parties.. This means that several conferences of different sizes can all run at the same time if the total calls do not exceed the systems conference resources. So the system will support 42 x 3-party conferences, 2 x 64-party conferences or any combination in between. IP Office does not impose limits on the mix of internal and external calls in conference, but if all internal participants disconnect from the conference bridge, the external participants can be disconnected automatically by the system for added security (configurable system setting).

Notes:

- 1. Analog Trunk Restriction**
In conferences that include external analog line calls, a maximum of two analog line calls are allowed per conference.
- 2. External Participants**
Each external caller requires a digital trunk/VoIP channel (for example 1 T1 allows 23/24 external parties, 1 E1 allows 30 parties and a fully licensed VCM-64 allows 64 parties).
- 3. Use of Conference Resources by Other Features**
System features such as call intrusion, call recording and silent monitoring all use conference resources, as does automatic recording if enabled. When any of these features are active the number of slots available for conference parties is reduced. For example, a conference call between 3 parties and being recorded will use 4 conference slots.
- 4. The IP500 Supports 128 Conference Members**
The total capacity of the IP500 or IP500 V2 is 128-party conference resources. However the restriction of a maximum of 64-parties in any individual conference still applies.
- 5. Meet-Me Conferencing on IP500 requires Preferred Edition**
IP Office 500 and IP500 V2 supports basic or ad-hoc conferencing, but if Meet-Me capabilities are required the Upgrade License to IP Office Preferred Edition should be purchased for direct dial into a conference bridge with PIN code security.

IP Office Standard Conferencing Features

The IP Office provides the following features and benefits relating to conferencing:

- **No special conferencing equipment required**
You only need an IP Office system unit with as many digital trunks/VoIP channels as external participants (as well as Preferred Edition for Meet-Me conferences).
- **Ease of use**
Simply dial the direct number allocated to the conference bridge, type in the PIN if required and you have joined the conference (PIN codes require Preferred Edition/VoiceMail Pro).
- **Conference control from Avaya Display phones*, IP Office Phone Manager and one-X Portal for IP Office**
For ad-hoc conferences with a few participants, users can easily set up immediate conferences by calling all parties and bringing them to the conference bridge. With one-X Portal for IP Office, the originator of the conference can keep control: the Caller ID number (and the associated name if recognized) of each participant is displayed. If required, they can selectively hang-up a specific participant.
- **Customized greeting**
Record a personalized greeting per conference (requires Preferred Edition/VoiceMail Pro).
- **Conference entry/exit tones**
Single beep on entry/double beep on exit
- **Conference call recording**
Manual recording initiated by user on IP Office via one-X Portal for IP Office, Phone Manager, digital/IP display phone or a short code (requires Preferred Edition/VoiceMail Pro)
- **Security**
To prevent unauthorized access to the conference bridge, PIN codes, Caller ID number screening as well as time and date profiles can be set-up using IP Office VoiceMail Pro.
- **Privacy**
In cases where the security of calls is critical, in-house conferencing is the only way to ensure privacy.
- **Remote Management**
Allows a single person to manage the conferencing bridge facility from any location. Furthermore, the full IP Office solution - phone system, voicemail, CTI server, router, firewall and DHCP server- can all be managed from a single management interface called IP Office Manager.

*Feature supported on 1408/1608/2410/5410/4610/5610 and 1416/1616/2420/5420/5621/4621/4625 as well as 9600 Series IP phones. Note that any internal party has the option to view & drop participants (not just the conference originator).

Chapter 15.

The Contact Center

15. The Contact Center

Avaya provides Customer Contact solutions that meet the needs of the small to mid-size business. From the smallest company that requires basic system performance reporting to the larger businesses that need advanced routing and multimedia integration with the Customer Contact Center. Avaya provides IP Office Customer Call Reporter as the perfect solution to meet the needs of small business customers.

Customer Call Reporter

Overview

Contact Centers are a requirement at nearly every level of business, from very small informal groups of 5 or 10 "customer service reps", to large formal campaigns that can involve thousands of agents.

However, customers in the small business market are generally very nervous about making such a high profile investment in a "contact center solution." They require a "business intelligence solution" that deploys easily, can be managed with very little training, and can provide statistics on each segment of the business. Small businesses also do not have the resources for extra IT staff to administer databases, servers, etc, so they need a solution that can be easily understood by their own employees. It should operate as a service to each of the clients.

IP Office Customer Call Reporter Concept

IP Office Customer Call Reporter is Avaya's new server based contact center product designed explicitly for small businesses. Drawing upon the latest web and design technologies, IP Office Customer Call Reporter introduces significant new capabilities to effectively and efficiently manage a multi-site call center environment. The product focus is on ease of use and deployment simplicity to ensure improved ongoing productivity and lower support costs.

In its native web server environment the IP Office Customer Call Reporter can be simply installed onto a single server without the need for any client software deployment. Administration and management of the call center is carried out via a thin client through a secure password protected web browser session.

IP Office Customer Call Reporter Key Features

- Real time Call Center activity monitor and historical reporting.
- Microsoft server based with thin client (web browser) client connections.
- Simplified installation and maintenance.
- Six reporting templates provide drag and drop and user defined filter functionality.
- Three customizable Supervisor views and summarized Agent views.
- Report Scheduler.
- Multi-lingual capable.
- Supports up to 30 Supervisors and 150 Agents.

IP Office Customer Call Reporter Business Benefits

- Lower TCO
IP Office Customer Call Reporter provides small businesses with a web based contact center measurement tool, producing cradle to grave reporting in an easily understandable format with no client software to load.
- Standards Based
IP Office Customer Call Reporter uses standards based applications, such as Microsoft SQL 2005 Express, and supports all major web browser software, to provide small business installers with greater flexibility in deployment.
- Ease of Use
IP Office Customer Call Reporter's real-time charts can be customized by the user in the manner that suits their business best, with historical reporting templates that allow the business to filter on the type of date they want to see.

Ordering IP Office Customer Call Reporter

Customer Call Reported supports the following maximum configurations for IP Office:

- 150 Agents
- 30 Supervisors

Activation of IP Office Customer Call Reporter is provided on an R6 system with the purchase of the IP Office Advanced Edition RFA, the Advanced Edition is a specialized call center bundle which also contains the following:

- Contact Store for IP Office (CSIPO)
- IVR Module
- VB Scripting
- Customer Call Reporter Supervisor (1 license)

Additional agents and supervisors can be purchased on top of Advanced Edition RFA

The IP Office Release 6 has a setting in IP Office Manager for designating which hunt groups will be reported upon by IP Office Customer Call Reporter. Any hunt group that contains an agent who is not properly licensed will not be able to retrieve any reporting on that group (real-time or historical).

IP Office Customer Call Reporter Server Operating System Requirements

The Customer Call Reporter server is supported on the following platforms:

- Microsoft Windows Server 2008 (All Versions)
- Microsoft Windows Business Server 2003 R2.
- Microsoft Windows Server 2003 SP2.
- Microsoft Windows Server 2003 R2.

IP Office Customer Call Reporter Server Hardware Requirements

The minimum server specifications are as follows:

- IP Office Customer Call Reporter server
Intel Pentium D 945 core/AMD Athlon 64 4000+ ; with 2GB RAM and 30 GB free hard disk space. Note:
The IP Office Customer Call Reporter server can co-reside with a VoiceMail Pro of less than 17 ports.

IP Office Customer Call Reporter Client Components

The client application consists of a secure thin client web browser session to the IP Office Customer Call Reporter server that will provide the Supervisor or Agent with a complete view of the Call Center.

The following web browsers will be supported:

- Microsoft Internet Explorer 7 and above. Internet Explorer 8 recommended.
- Mozilla Firefox, version 3.0 and above.
- Windows Safari 3.1 and above.
- Apple Safari 3.1 and above.

IP Office Customer Call Reporter Database

The database has been designed to provide a simple table schema. The database is a Microsoft SQL Server 2005 instance and the IP Office Customer Call Reporter will be packaged with the Microsoft SQL Server 2005 Express edition. It is recommended that any call center that predicts high call usage should understand the imposed limitations of Microsoft SQL 2005 Express edition and consider using the full version of Microsoft SQL 2005. Microsoft SQL 2000 and 2008 are not supported.

The database is a "pre-requisite" that must be installed prior to the IP Office Customer Call Reporter install. During installation the default location for the installation of the database is on the local drive. This can be changed to a remote location on the network. If an existing database is to be used then the option for this to exist on a remote server also applies.

Historical Reporting

The IP Office Customer Call Reporter reporting package has been simplified to enable the user to easily retrieve the reporting information they need from one of seven standard drag and drop report templates. The IP Office Customer Call Reporter offers "cradle to grave" reporting for businesses that want to track specifically how a call was routed through their business. The historical reporting is accessed via the Supervisor login and corresponding view as shown below.



The screenshot shows a web browser window with the AVAYA logo at the top left. The title of the window is "IP Office Customer Call Reporter". At the top right of the window, there are three links: "Forgot Password" (with an exclamation mark icon), "Status" (with a red square icon), and "Help" (with a question mark icon). Below the logo, the text "IP Office Customer Call Reporter" is displayed. There are three input fields: "Username:" with the text "mark", "Password:" with a masked password of ten dots, and "Language:" with a dropdown menu showing "English-UK". A "Logon" button is located below the input fields.

IP Office Customer Call Reporter Report Templates

The following main report templates are available with IP Office Customer Call Reporter:

- **Agent Summary Report**
This report type details the call activity for agents in a queue or for specific agents.
- **Call Details Report**
The Call Details Report contains details of the total number of calls, internal calls (optional), external outbound calls and the total number of external inbound calls.
- **Call Summary Report**
The Call Summary Report contains details of the total calls presented and answered; the average speed to answer percentage and average speed to answer time, the number of calls overflowed and lost, the average abandon time as well as the grade of service.
- **Trace Reports**
The Trace Report lists in chronological order all the events, date and time stamped that involved the subject selected.
- **Alarm Reports**
Alarm reports can be created for the Supervisor Views. All the alarms for the selected subject are listed over a user specified time period. Totals are included that show the number of warning and critical alarms received for each unique alarm type included in the report.
- **Voicemail Reports**
The report shows the following information; Total calls answered by the Auto-Attendant (VMPro), total calls abandoned (lost) in Auto-Attendant, and a table of unique call flow trigger names with a tally of the number of times the trigger has been received (e.g. who pressed 1 for sales in the Auto-Attendant).

Creating an IP Office Customer Call Reporter Report

From the seven basic report templates within IP Office Customer Call Reporter, a user can create over 100 different reports depending upon how they want to see the information that is most useful for their business. All standard report templates have common fields that can be completed to create a report. And when entering details in a field a wildcard '*' can be used to represent everything. The common fields are listed below:

- **Report Name**
The text entered is used as the main title of the report. If the report is saved this is the saved name of the report.
- **Subject**
This is the main subject of the report. The drop down list offers a list of report subjects that are pertinent to the report i.e. Hunt Group, Agent, DDI etc.
- **Filter**
The filter is used to refine the data and again offers filters that are pertinent to the report i.e. All, Answered, Lost, etc.
- **Exclude Internal**
When selected, internal calls are excluded from the report.
- **Working Hours**
The start and finish time of the working day can be specified using the spin controls.
- **Group Results by**
The drop down list offers a list of display options.
- **Scheduled**
By default this field is shown as 'Manual'. If the option 'Scheduled' is selected then additional fields are available:
- **Report Format**
The format that the report is to be produced in can be selected from Adobe, Word, Excel, Rich Text or Crystal.
- **Email Address**
An email address can be entered if the report is to be sent by email.
- **Printer**
The printer path that the report should be sent to.
- **Report Period**
Selection of days, weeks or months from a list box. The number of days or weeks is counted from the date that the report is first scheduled to be run. Months are from the last full months data i.e. if the report is scheduled in February then January will be the last month in the report.
- **Report Range**
The start and end date for the report.
- **Language**
If the default language is not required then another language can be selected that your system supports.

Filters can be used in the report to provide exactly the type of information the customer is looking for. The filter field is used to refine the data and offers the following options in a drop down list; All, Answered, Refused, Refused Overflowed, Overflowed All, Overflowed Off PBX, Overflowed on PBX, Transferred and Lost Calls. The default setting is all.

Reports can also be scheduled for future delivery to any network printer or email address in any of the supported formats.

IP Office Customer Call Reporter Report Examples

Call Details Report

3 / 3 100%

My Call Details

From 01/12/2008 - 22/12/2008 09:00 - 17:00

Report Type	Target Name	Supervisor Name							
Call Details Report - All	Queue	Mark Gallagher							
<u>Ungrouped</u>									
Time Stamp	Call Direction	Number	DDI	Queue	Queue Time	Agent	Duration	Status	Reference
02/12/2008 13:09:37	Inbound	01707364416	200	Queue	00:00:01	Agent A	00:00:01	Answered	000140
02/12/2008 13:10:18	Inbound	01707364416	200	Queue	00:00:06	Agent A		Answered	000141
04/12/2008 12:31:28	Inbound	01707364416	200	Queue	00:00:07	Agent A		Lost	000143
04/12/2008 12:32:12	Inbound	01707364416	200	Queue	00:00:02	Agent A	00:00:04	Answered	000144
04/12/2008 12:56:14	Inbound	01707364416	200	Queue	00:00:02	Agent A	00:00:07	Answered	000145
Summary									
Total Calls		28	External Inbound Calls		23				
Internal Calls		5	External Outbound Calls		0				

Call Summary Report

1 / 1 100%

My Call Summary Report

From 01/12/2008 - 22/12/2008 9:00 - 17:00

Report Type	Target Name	Supervisor Name									
Call Summary Report	Queue	Mark Gallagher									
<u>Ungrouped</u>											
	Presented Calls	Answered Calls	Lost Calls	Overflowed Answered	Overflowed Lost	Routed To Voicemail	No Answer	Avg. Speed to Answer (%)	Avg. Speed to Answer (Time)	Avg. Abandon Time	Grade Of Service (%)
MainB	1	1	0	0	0	0	0	0.00			0.00
Queue	23	17	9	0	0	0	0	52.94	00:00:01	00:00:08	37.50
Queue2	2	2	0	0	0	0	0	0.00	00:00:02		0.00
	Presented Calls		26		Average Speed to Answer (%)		50.00				
	Answered Calls		20		Average Speed to Answer (Time)		00:00:01				
	Lost Calls		9		Average Abandon Time		00:00:08				
	Overflowed Answered		0		Grade of Service		36.00				
	Overflowed Lost		0		Answer Threshold		1				
	Routed To Voicemail		0		Lost Call Threshold		1				
	No Answer		0		External Outbound		0				

Supervisor Wallboard

For the release of IP Office R6, Customer Call Reporter now provides a browser based wallboard that can be used in businesses who want to display key statistics in a group area, such as on an LCD television screen.

The wallboard has the ability to display all the statistics currently available within Customer Call Reporter, but can also provide two additional new features:

- A scrolling message board, for important messages during the course of the working day
- A standings or “leader” board, which displays the top agents for a particular activity during the day

In addition to this, the wallboard can also be customized with the company’s logo and colors. Also, there is no limit to the number of statistics that can be displayed (caution: adding too many statistics may cause the displayed statistics to be too small to be viewed reasonably).

Wallboard Requirements

- The wallboard can run on all the supported browsers for Customer Call Reporter
- Microsoft Silverlight is a required plug in that can be downloaded before starting the wallboard

Wallboard Licensing

The Customer Call Reporter wallboard is based upon the number of supervisors licensed within CCR, for each supervisor license purchased; there can be one instance of the wallboard. If five supervisor licenses are active on the system, then five instances of the wallboard can be used throughout the business. The wallboard logins do not have to be unique, for example, the system may have only one wallboard account set up within CCR, but that same account can be used for as many supervisor licenses that exist on the system.



Real Time Reporting

Customer Call Reporter provides real time monitoring of call center activity. This is achieved via a thin client web browser session logged onto the IP Office Customer Call Reporter server. Within the supervisor client a user can program up to 3 different views of their call center. This is a very useful feature as now a supervisor can divide their responsibilities into different views and compare the results of those views.

For example, assume that a call center supervisor is responsible for the following hunt groups in IP Office; Computer Sales (201), Monitor Sales (202), Warranty Service (203), and non-Warranty service. The Supervisor can create two separate views entitled "sales" and "service" and compare the number of calls, length of call, etc. This allows a supervisor to see a whole system as it relates to the business function (sales, service).

The Supervisor views are private and can only be seen with a login. A view may be created that shows specific Hunt Group and Agent statistics as well as Alarms and Warnings. Each of the three views are summarized and made available to any Agents when they login and select their corresponding Supervisor. An example of the Supervisor real-time view is shown below:

Alarm Ticker Current Views

09:33 Alarm [HG502](#) 7 Calls Waiting

Queues	Calls Waiting	Answered Calls	Lost Calls	Average Ans %	Average Ans Time	Grade Of Service
HG510	2	931	28	17.61	3.8	10.91
HG503	7	103	28	21.12	3.74	11.11
HG501	2	242	26	14.14	3.66	7.14
HG502	7	617	95	39.48	3.75	29.74
HG500	1	469	4	65.46	3.71	57.65
TOTAL			97	31.56	3.73	23.31

Longest Wait Time Internal: 49
Average Wait Time Internal: 16

Agents	Answered Calls	Refused Calls
Extn255		

Alarm List All Views

09:33 Alarm [HG502](#) 35 Calls Waiting
 09:33 Alarm [HG500](#) 57.65% Grade Of Service
 09:33 Alarm [HG510](#) 2 Calls Waiting
 09:33 Alarm [HG503](#) 11.12% Grade Of Service
 09:33 Alarm [HG510](#) 10.91% Grade Of Service

Alarms

The Customer Call Reporter provides different levels of alarms for the supervisor and agent to properly manage their call center activity. As parameters move from a normal to alarm state, the color of the field within the realtime view will change depending upon the level of alarm; white for normal, yellow for caution, red for alarm, and blue for alarm acknowledged. The following statistics can have alarms set against them within the IP Office Customer Call Reporter:

Statistic Full Name	Available for		Warning/ Alarm Type
	Queue	Agent	
Agent State (Queue) Time	-	✓	>1-999
Agents ACW	✓	-	>1-150
Agents Available	✓	-	<1-150
Agents Logged On	✓	-	<1-150
Answered Calls	✓	✓	>1-999
Answered External (Non-Queue)	-	✓	>1-999
Answered Internal (Non-Queue)	-	✓	>1-999
Answered Internal (Queue)	✓	✓	>1-999
Average Answer %	✓	✓	<1-100%
Average Answer Time	✓	✓	>1-600
Average Wait Time	✓	-	>1-600
Busy Not Available	✓	-	>1-150
Calls Waiting	✓	-	>1-999
Current Wait Time	✓	-	>1-600
Grade of Service	✓	-	<1-100%
Internal Made	-	✓	>1-999
Longest Wait Time	✓	-	>1-600
Lost Calls	✓	✓	>1-999
New Messages	✓	-	>1-999
No Answer	✓	✓	>1-999
Outbound Calls (External)	-	✓	>1-999
Overflowed Answered	✓	-	>1- 999
Overflowed Calls	✓	-	>1-999
Overflowed Calls Waiting	✓	-	>1-999
Overflowed Lost	✓	-	>1-999
Queue State Time	✓	-	>1-600
Routed to Other	✓	✓	>1-999
Routed to Voicemail	✓	✓	>1-999
Transferred	✓	✓	>1-999

Agent View

In Customer Call Reporter, the Agent view is part of the agent reporting license, every licensed agent will be able to run their own view. An Agent is able to login via a thin client web browser session and associate with a Supervisor. The Agent view also displays any alarms that have been set by the Supervisor.

The screenshot displays the Agent View interface. At the top, there are three view tabs: 'View 1', 'View 2', and 'View 3'. Below the tabs is a navigation bar with icons and labels for 'Graph', 'Change Password', 'Log Off', 'Status', and 'Help'. The main content area is divided into three sections:

- Alarm Ticker All Views:** A section with a yellow background, currently empty.
- Summary Tables:**
 - Queues Table:**

Queues	Overflowed Answered	Overflowed Calls Waitg	Transferred	Queue State	Answered Calls
Queue	0	0	0	In Service	0
TOTAL	0	0	0		0
 - Agents Table:**

Agents	Agent State(Q) T	Answered Calls	Agent State(Q)
Agent A	00:00:32	0	Available
- Alarm List All Views:** A section with a yellow background, currently empty.

Call Statistics

The Customer Call Reporter provides detailed statistics to help small businesses understand exactly where a call has been within the business. Statistics are measured against (also refer to the table below):

- Queues
Points in the call center where a queue forms such as hunt groups.
- Agents
Individuals that are members of queue groups who answer the calls.

Statistic Full Name	Available for		Call Type ^[1]		Warning/ Alarm Type	Include Overflow	
	Queue	Agent	Ext'	Int'		From	To
Agent State (Queue)	-	✓	-	-	None	-	-
Agent State (Queue) Time	-	✓	-	-	>1-999 ^[2]	-	-
Agent State (System)	-	✓	-	-	None	-	-
Agent State (System) Time	-	✓	-	-	None	-	-
Agents ACW	✓	-	-	-	>1-150	-	-
Agents Available	✓	-	-	-	<1-150	-	-
Agents Call Share	-	✓	-	-	None	-	✓
Agents Logged On	✓	-	-	-	<1-150	-	-
Agents Present	✓	-	-	-	None	-	-
Agents Ringing	✓	-	✓	✓	None	-	✗
Answered Calls	✓	✓	✓	✓	>1-999	✗	✗/✓ ^[3]
Answered External (Non-Queue)	-	✓	✓	-	>1-999	-	-
Answered Internal (Non-Queue)	-	✓	-	✓	>1-999	-	-
Answered Internal (Queue)	✓	✓	-	✓	>1-999	✗	✗
Average Answer %	✓	✓	✓	✓	<1-100%	✓	✗
Average Answer Time	✓	✓	✓	✓	>1-600	✓	✗
Average Wait Time	✓	-	✓	✓	>1-600	✓	✗
Busy Not Available	✓	-	-	-	>1-150	-	-
Calls Waiting	✓	-	✓	✓	>1-999	✗	✓
Current Wait Time	✓	-	✓	✓	>1-600	✓	✓
Grade of Service	✓	-	✓	✓	<1-100%	✓	✗
Internal Made	-	✓	-	✓	>1-999	-	-
Longest Wait Time	✓	-	✓	✓	>1-600	✓	✗
Lost Calls	✓	✓	✓	✓	>1-999	✗	✗/✓ ^[3]
New Messages	✓	-	-	-	>1-999	-	-
No Answer	✓	✓	✓	✓	>1-999	✗	✗/✓ ^[3]
Outbound Calls (External)	-	✓	✓	-	>1-999	-	-
Overflowed Answered	✓	-	✓	✓	>1-999	✓	✗
Overflowed Calls	✓	-	✓	✓	>1-999	✓	✗
Overflowed Calls Waiting	✓	-	✓	✓	>1-999	✓	✗
Overflowed Lost	✓	-	✓	✓	>1-999	✓	✗
Queue State	✓	-	-	-	None	-	-
Queue State Time	✓	-	-	-	>1-600 ^[2]	-	-
Routed to Other	✓	✓	✓	✓	>1-999	✓	✗
Routed to Voicemail	✓	✓	✓	✓	>1-999	✓	✗
Transferred	✓	✓	✓	✓	>1-999	✓	✗

Chapter 16.

Management Utilities

16. Management Utilities

This section gives an overview of the management applications that are common to all IP Office platforms.

- [IP Office Manager](#)^[294]
IP Office's main configuration tool.
- [Monitor](#)^[294]
A trace utility for trouble shooting.
- [SNMP](#)^[295]
Alerts and alarms from IP Office systems to SNMP tools or to SMTP email.
- [System Status Application \(SSA\)](#)^[296]
Outputs call detail records for off A diagnostic tool to monitor and check the status of IP Office systems.

IP Office Manager

This application is IP Office's main configuration tool. Using a Windows Graphical User Interface, Manager provides an intuitive interface for installation, configuration and subsequent moves and changes. As with all IP Office applications, the Manager is multi-lingual and coupled with the ability to use the application both locally and remotely, it is possible for an administrator to manage any of their IP Offices from any country using their local language preference. Access to each IP Office is protected by passwords and definable user rights. This allows Manager to operate according to the individual administrator's level of expertise.

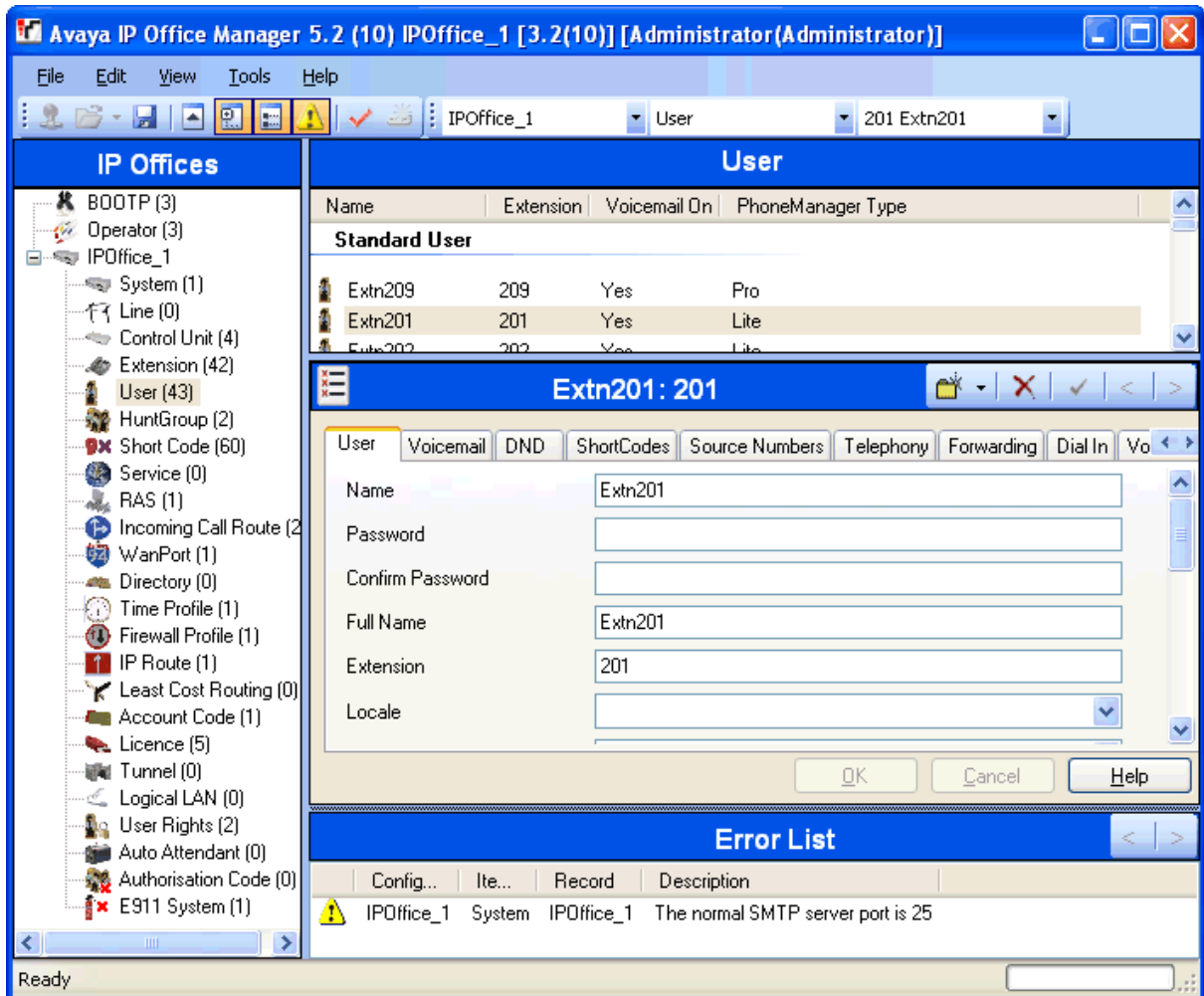

The IP Office Manager operates on a local copy of the IP Office configuration file. Configurations are prepared and reviewed 'off line' before committing to the IP Office. This has the benefit of ensuring a backup copy of the system configuration is always available for disaster recovery.

IP Office has a built-in audit trail that tracks changes to the system configuration, and who has made them. Manager can display the audit trail to assist with problem resolution. The Audit trail records the last 15 changes in the configuration and records the following elements:

- Configuration Changed - For configuration changes, the log will report at a high level on all configuration categories (users, hunt group...) that have been changed.
- Configuration Erased
- Configuration merged
- Reboot – user instigated reboot.
- Upgrade
- Cold Start
- Warm Start
- Write at HH:MM – This is when the administrator saved the configuration via the schedule option
- Write with Immediate Reboot
- Write with Reboot When Free

The screenshot shows the 'IPOffice Audit Trail' window. It contains a table of system events and an 'Audit Details' section for the selected event.

Date And Time Of Access	Security User	AccessType	Outcome
30 March 2006 12:41:24	Administrator	Write With Merge	Success (clean)
30 March 2006 12:45:41	Administrator	Write With Merge	Success (clean)
30 March 2006 12:47:43	Administrator	Write With Merge	Success (clean)
03 April 2006 10:29:49	Administrator	Write With Merge	Success (clean)
03 April 2006 10:33:29	Administrator	Write With Merge	Success (clean)
03 April 2006 13:11:33	Administrator	Write With Merge	Success (clean)
04 April 2006 09:32:14	System Reboot	Warm Start	Success
04 April 2006 10:09:42	Administrator	Write With Merge	Success (Warning)
04 April 2006 10:12:20	Administrator	Write With Merge	Success (Warning)
04 April 2006 12:52:05	Administrator	Write With Merge	Success (Warning)
04 April 2006 12:55:59	Administrator	Write With Merge	Success (Warning)
06 April 2006 15:32:23	Administrator	Security Login	Failure

Audit Details

Security User	Administrator	Items Changed	
Date and Time of Access	04 April 2006 12:52:05	Item Type	Item Name
PC Login	Avaya123	User	Extn207
PC IP Address	192 · 168 · 42 · 203	Account Code	Account Code
PC MAC Address	00 : 13 : d3 : a7 : 7a : 06		
Access Type	Write With Merge		
Outcome	Success (Warning)		

Buttons: Cancel, Help

Manager is also used for maintenance functions such as:

- Upgrade to the IP Office system software.
 - Systems running 2.1 or later have the added benefit of being able to send software over an IP network link to a system and have it validated before committing to the upgrade
- IP Office Manager Release 6 is backwards compatible with systems from release 2.1 onwards to allow a single management application.
- Importing and Exporting IP Office configuration information in ACSII-CSV files. Manager will create files for the following data
 - Configuration.csv which is a complete list of items as per Manager 5.1 and earlier
 - Directory.csv containing fields NAME, NUMBER
 - HuntGroup.csv containing fields HUNT GROUP NAME, HUNT GROUP EXTENSION, GROUP, HUNT, ROTARY, IDLE, QUEUING, VOICEMAIL, BROADCAST MESSAGES, EMAIL ADDRESS
 - License.csv is import only containing fields LICENCE OPTION, LICENCE KEY
 - ShortCode.csv containing fields SHORT CODE, TELEPHONE NUMBER, FEATURE NAME
 - User.csv containing fields NAME, EXTENSION NUMBER, USER RIGHT, EMAIL ADDRESS
- User templates for rapid programming and user rights for setting up user access levels

Monitor

The IP Office Monitor application is a real-time maintenance utility to assist with IP Office trouble-shooting. As the application connects to the IP Office over an IP connection it can be used from both local (LAN) and remote locations (WAN).

A simple interface allows an engineer to select which protocols and interfaces are to be monitored and decoded. The trace can either be captured directly to screen or as a log file for later analysis. Traces from different protocols can be color coded to improve the clarity of large log files. In addition to monitoring, the application captures system alarms and will display an activity log of the last 20 alarms that have occurred.

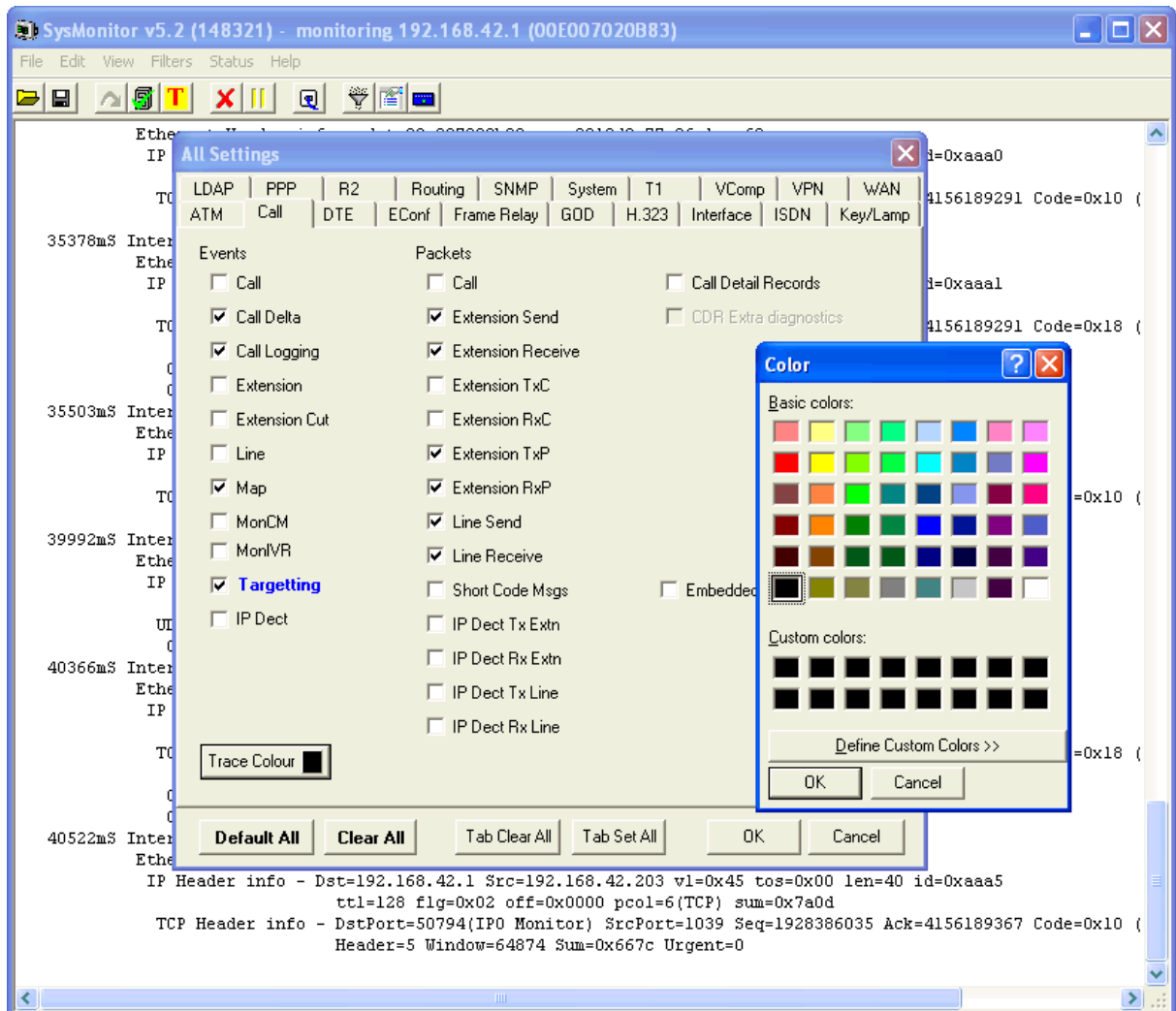

Simple Network Management Protocol (SNMP)

SNMP is an industry standard designed to allow the management of data equipment from different vendors using a single Network Manager application. The Network Manager will periodically poll equipment to solicit a response, if no response is received an alarm is raised. In addition to responding to polls, IP Office monitors the state of its Extensions, Trunk cards, Expansion Modules (except WAN3 module) and Media cards so that if an error is detected IP Office will notify the Network Manager. IP Office allows two separate Network Managers to be configured so that both a customer's Network Manager and a Maintainer's Network Manager to be notified of the same alarm condition. As the IP Office solution comprises many applications, the core software notifies SNMP events from both VoiceMail Pro and Embedded voicemail to warn of approaching storage capacity limits.

IP Office has been tested against CastleRock's SNMPc-EE™ and HP's Network Node Manager (part of the OpenView application suite).

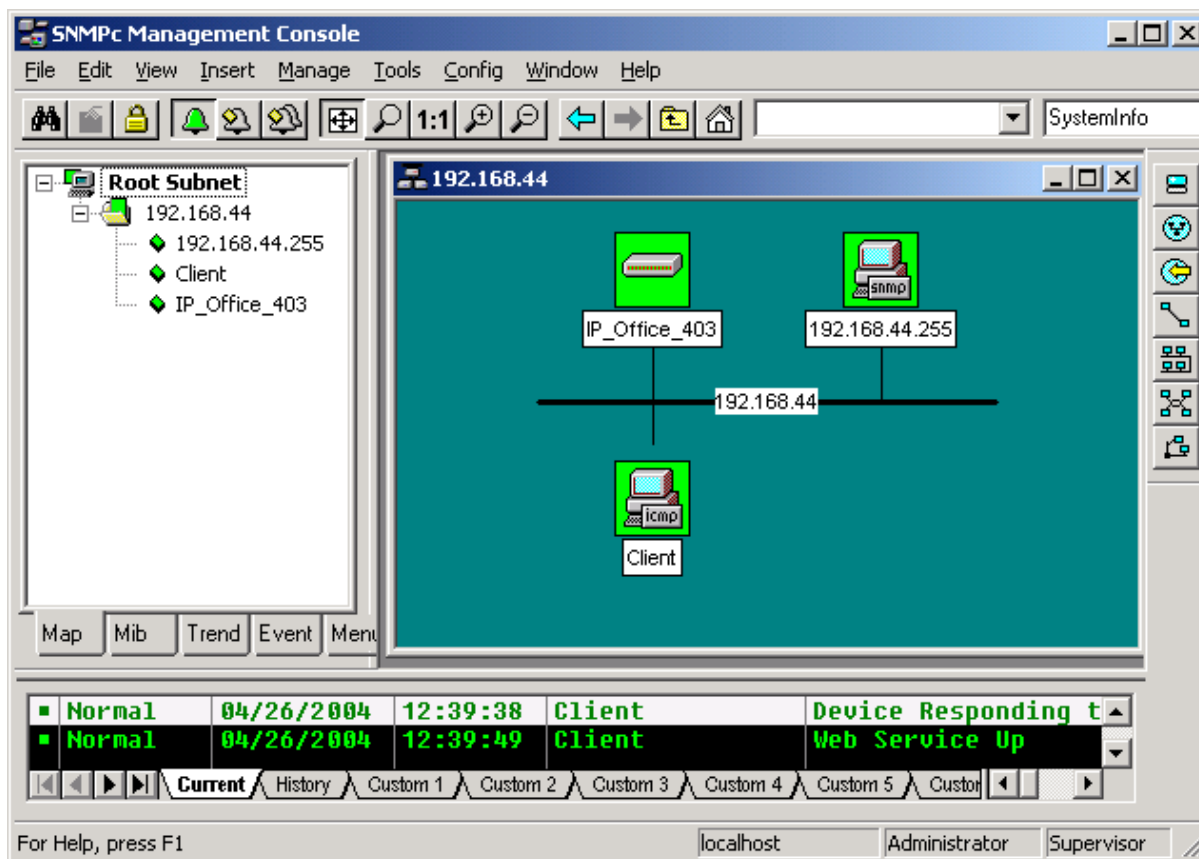

On customer sites where SNMP management is not available, IP Office can email events using up to 3 email addresses each containing a different set of alarms. The following system event categories can be chosen for email notification, if installed on the system:

- Generic
- Trunk lines
- Embedded Messaging Card
- VCM
- Expansion modules
- Applications
- License
- Phone change
- CSU Loop-Back

IP Office sends email notifications directly to the email server; no additional PC client is needed.

System Status Application

The System Status Application (SSA) is a diagnostic tool for system managers and administrators to monitor and check the status of IP Office systems locally or remotely. SSA shows both the current state of an IP Office system and details of any problems that have occurred. The information reported is a combination of real-time events, historical events, status and configuration data to assist fault finding and diagnosis. SSA provides real-time status, historic utilization and alarm information for ports, modules and expansion cards on the system. SSA connects to all variants of IP Office running release 4.0, using an IP connection that can be remote or local. Modem connections at 14.4kbps or above are supported for remote diagnostics.

SSA provides information on the following:

- Alarms
SSA displays all alarms which are recorded within IP Office for each device in error. The number, date and time of the occurrence is recorded. The last 50 alarms are stored within IP Office to avoid need for local PC.
- Call Details
Information on incoming and outgoing calls, including call length, call ID and routing information.
- Extensions
SSA details all extensions (including device type and port location) on the IP Office system. Information on the current status of a device is also displayed.
- Trunks
IP Office trunks and connections (VoIP, analog and digital) and their current status are displayed. For VoIP trunks, QoS information is also displayed (e.g. round trip delay, jitter and packet loss).
- System Resources
IP Office includes central resources that are utilized to perform various functions. Diagnosing these resources is often critical to the successful operation of the system. This includes details on resources for VCM, Voicemail and conferencing.
- QoS Monitoring
QoS Parameters from connected calls, such as jitter and roundtrip delay, are monitored.

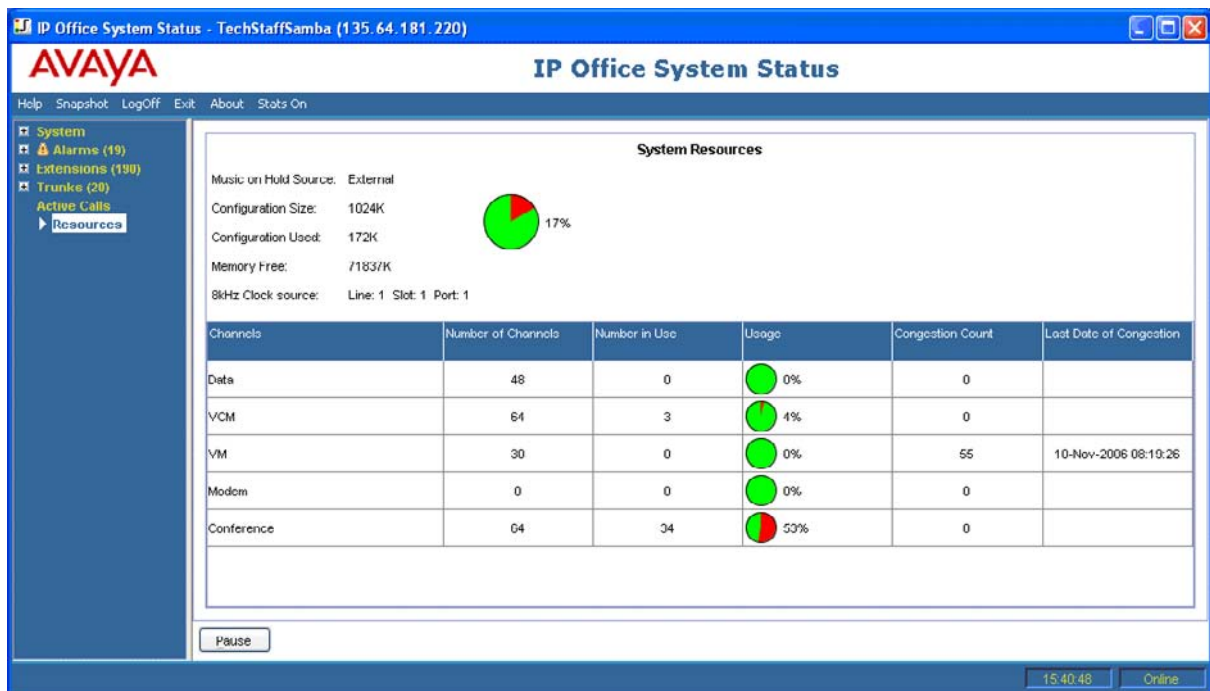

SSA can be launched independently or from IP Office Manager and there can be up to two (2) SSA clients connected to an IP Office unit at one time.

Note: SSA is not a configuration tool for IP Office systems. For information on configuration, refer to IP Office Manager.

Chapter 17.

Configurations

17. Configurations

IP500 V2 Control Unit (700476005)

Includes: 4 x front slots for combinations of extension/VCM/combo cards and trunk daughter cards, 1 x System SD card slot for:

- software image
- configurations and country settings
- license keys
- phone firmware
- music on hold
- embedded voicemail prompts and recordings

1 x Optional SD card slot for software upgrade image, 2-port Layer-3 LAN switch, 9-pin DTE serial port for system diagnostics, 3.5 mm jack for Music-on-Hold audio input and 2-switch external door-relay control port. 8 x external expansion module ports to support additional analog trunks, digital or analog extensions. Includes auto ranging internal power supply. Regional power cord and software/documentation CD pack not included. Only one variant of control unit is available, but regional locale is determined by the appropriate System SD card feature key (mandatory):

- IP Office 500 V2 Software License Feature Key Mu-Law (700479710)
Configures the control unit for Mu-law voice encoding and US locale settings.
- IP Office 500 V2 Software License Feature Key A-Law (700479702)
Configures the control unit for A-law voice encoding and multi-country locale settings.
- IP Office 500 V2 Software License Feature Key IP Office Partner Version (700479728)
Configures the control unit for the NA Partner Version.

IP500 Control Unit (700417207)

Includes: 4 x front slots for combinations of extension/VCM cards and trunk daughter cards, 1 x smart card slot for locale settings and license feature key, 1 x compact flash slot for embedded voicemail option, 2-port Layer-3 LAN switch, 9-pin DTE serial port for system diagnostics, 3.5 mm jack for Music-on-Hold audio input and 2-switch external door-relay control port. 8 x external expansion module ports to support additional analog trunks, digital or analog extensions. Includes auto ranging internal power supply. Regional power cord and software/documentation CD pack not included. Only one variant of control unit is available, but regional locale is determined by the appropriate smart card feature key (mandatory):

- IP Office 500 Software License Feature Key Mu-Law (700417470)
Configures the control unit for Mu-law voice encoding and US locale settings.
- IP Office 500 Software License Feature Key A-Law (700417488)
Configures the control unit for A-law voice encoding and multi-country locale settings.

IP Office External Expansion Modules

Except where noted, all the following are supported by the IP406 V2, IP412, IP500 and IP500 V2 control units.

IP500

- IP Office 500 Expansion Module Phone 16 (700449507)
Adds an additional 16 analog Plain Ordinary Telephone ports to control units.
- IP Office 500 Expansion Module Digital Station 16 (700449499)
Adds an additional 16 Digital Station ports to control units.
- IP Office 500 Expansion Module Phone 30 (700426224)
Adds an additional 30 analog Plain Ordinary Telephone ports to control units.
- IP Office 500 Expansion Module Digital Station 30 (700426216)
Adds an additional 30 Digital Station ports to control units.
- IP500 Analog Trunk 16 - *North America only* (700449473)
Provides an additional 16 Analog trunks (loop start or ground start) and two power fail sockets.

IP500 and IP500 V2 Base Cards

Only supported in the IP500 and IP500 V2.

- IP Office 500 Extension Card Digital Station 8 (700417330)
- IP Office 500 Extension Card Phone 8 (700417231)
- IP Office 500 Extension Card Phone 2 (700431778)
- IP500 Media Card Voice Compression Module 32 (700417389)
Voice Compression Module required for IP trunks and extensions. 4 channels are enabled by default. Additional channels up to the maximum of 32 are enabled through license keys. Includes 128ms echo cancellation.
- IP500 Media Card Voice Compression Module 64 (700417397)
Voice Compression Module required for IP trunks and extensions. 4 channels are enabled by default. Additional channels up to the maximum of 64 are enabled through license keys. Includes 128ms echo cancellation.
- IP Office 500 Carrier Card (700417215)
Supports a range of IP400 trunk cards.
- IP Office 500 V2 Combination Card with 4 analog trunks (700476013 – IP500 V2 only)
Combination Card with 4 analog trunks, 6 Digital Station (DS), 2 Phone ports and 10 VCM channels.
- IP Office 500 V2 Combination Card with 2 BRI trunks (700476021 – IP500 V2 only)
Combination Card with 2 BRI trunk interfaces (4 channels), 6 Digital Station (DS), 2 Phone ports and 10 VCM channels.
- IP Office 500 V2 ETR 6 port phone card (700476039 – IP500 V2 only)
Supports 6 ETR ports for ETR 6/18/34 D, Euro-Style and Refresh digital phones as well as 3910/3920 wireless phones. Supported on IP Office Essential Edition – PARTNER Version only.

IP500 and IP500 V2 Trunk Daughter Cards

Only supported in the IP500. Each requires an IP500 base card other than the IP500 Carrier card.

- IP Office 500 Trunk Card Analog 4 Universal (700417405)
- IP Office 500 Trunk Card Primary Rate 1 Universal (700417439)
- IP Office 500 Trunk Card Primary Rate 2 Universal (700417462)
- IP Office 500 Trunk Card Basic Rate 4 Universal (700417413)
- IP Office 500 Trunk Card Basic Rate 8 Universal (700417421)

Country Availability

IP Office is available from distribution partners in the following countries. Please refer to your country price list for the availability of individual items.

Americas	Europe, Middle East and Africa		Asia Pacific
<ul style="list-style-type: none"> • Argentina • Brazil • Canada • Chile • Colombia • Mexico • Peru • USA 	<ul style="list-style-type: none"> • Austria • Belgium • Bulgaria • Croatia • Cyprus • Czech Republic • Denmark • Estonia • Finland • France • Germany • Greece • Hungary • Iceland • Ireland • Italy 	<ul style="list-style-type: none"> • Latvia • Lithuania • Luxembourg • Malta • Netherlands • Norway • Poland • Portugal • Romania • Russia • Slovenia • Slovakia • South Africa • Spain • Sweden • Switzerland • United Kingdom 	<ul style="list-style-type: none"> • Australia • China • Hong Kong • India • New Zealand • South Korea • Taiwan

Sample Configurations

Scenario 1:

A three location US business working in property/building management would like to optimize their customer service and satisfaction and lower the costs. The work roles are:

- 30 building managers, 10 in each location partly at the customer site.
- 80 property maintenance associates, about 30 in each location mostly at the customer site.
- 1 manager
- 6 back office associates, two at each site
- 9 shared desks, 3 at each site for property maintenance associates
- 6 phones, 3 at each site in meeting and facility rooms
- 6 Fax machines, 2 at each location

All employees should be accessible at anytime under one number service.

Kit List

- 3 x IP500 V2 Control Unit
- 3 x IP500 Analog Phone 2 Card
- 3 x IP500 Universal PRI Trunk Card (with additional channel licenses to allow 16 active channels per site)
- 3 x IP500 VCM 32 Card
- 3 x Region specific power cord.
- 3 x IP500 V2 feature key System SD Card
- 6 x 1603 (for the meeting and facility rooms)
- 15 x 1608 (for the back office associates and shared desks)
- 30 x 1616 IP Phones (for the building managers)
- 1 x 9650 IP phones (for the manager)
- 3 x Voice Networking license (4 channels)
- 3 x 20 User Avaya IP Endpoint license
- 1 x Preferred Edition.
- 1 x Advanced Edition..
- 2 x 20 User Power license (for the building managers and the manager).
- 1 x 5 User Office Worker license (for the back office associates).
- 1 x 1 User Office Worker license (for the back office associates).
- 4 x 20 User Mobile Worker license (for the property maintenance associates).

Scenario 2:

A one location German business working in capital goods industry would like to optimize their communication and lower the costs. The work roles are:

- 3 account managers often on the road or on customer site but sometimes in their home office as well.
- 5 service technicians in the field
- 10 assembly operators in the manufacturing plant
- 3 managers
- 5 back office associates
- 2 shared desks for account managers and service technicians
- 3 phones in meeting room and facility room
- 2 Fax machines

All employees should be accessible at anytime under one number service.

Kit List

- 1 x IP500 V2 Control Unit
- 2 x IP500 V2 Combination Card with 2 BRI trunks
- 1 x Region specific power cord
- 1 x IP500 V2 feature key System SD Card (including Essential Edition / 2 Port embedded voice mail)
- 3 x 1603 (for the facility rooms)
- 12 x 1608 (for the assembly operators and shared desks)
- 5 x 1616 IP Phones (for the back office associates)
- 3 x 9620 IP Phones with VPN Software (for the account managers at home)
- 3 x 9650 IP phones (for the managers)
- 1 x 20 User Avaya IP Endpoint license
- 2 x 5 User Avaya IP Endpoint license
- 2 x 5 User Power license (for the account managers and service technicians)
- 1 x 5 User Office Worker license (for the back office associates)
- 1 x 5 User Mobile Worker license (for the Managers)

Scenario 3:

A lawyer's office has the need of a new communication solution to lower costs and speed up customer service. The work roles are:

- 3 lawyers
- 6 administrators
- 1 meeting room
- 2 Fax machines

All employees should be accessible at anytime under one number service.

Kit List

- 1 x IP500 V2 Control Unit
- 2 x IP500 V2 Combination Card with 2 BRI trunks
- 1 x Region specific power cord
- 1 x IP500 V2 feature key System SD Card (including Essential Edition / 2 Port embedded voice mail)
- 1 x 1403 (for the meeting room)
- 6 x 1416 (for the administrators)
- 3 x 9650 IP phones (for the lawyers)
- 3 x 1 User Avaya IP Endpoint license
- 3 x 1 User Power license (for the lawyers)
- 1 x 5 User Office Worker license (for the administrators)
- 1 x 1 User Office Worker license (for the administrators)

Chapter 18. TAPI Functions Supported by IP Office

18. TAPI Functions Supported by IP Office

TAPI 2.1 Functions Supported

TAPI *Lite* provides the following functionality for TAPI 2.1:

- lineAddToConference
- lineAnswer
- lineBlindtransfer
- lineCompleteTransfer
- lineConfigDialog
- lineClose
- lineDeallocateCall
- lineDial
- lineDrop
- lineGetAddressCaps
- lineGetAddressID
- lineGetAddressStatus
- lineGetAppPriority
- lineGetCallInfo
- lineGetCallStatus
- lineGetDevCaps
- lineGetID
- lineHold
- lineInitialiseEx
- lineMakeCall
- lineNegotiateTAPIVersion
- lineOpen
- linePark
- lineRedirect
- lineRemoveFromConference
- lineSetAppPriority
- lineSetAppSpecific
- lineSetCallPrivilege
- lineSetStatusMessages
- lineSetupTransfer
- lineShutdown
- lineSwapHold
- lineUnhold
- lineUnpark
- lineSetCallData
- lineDevSpecific
- lineGenerateDigits
- lineGenerateTone
- lineMonitorDigits
- lineMonitorTones

TAPI 3.0 functions supported

The following functions are supported using TAPI 3.0:

- ITTAPI
- Initialize
- Shutdown
- EnumerateAddresses
- RegisterCallNotifications
- Put_EventFilter
- I TAddress
- get_AddressName
- get_dialableAddress
- get_ServiceProviderName
- CreateCall
- I TMediaSupport
- get_MediaTypes
- I TCallInfo
- get_Address
- get_CallState
- get_CallInfoString
- SetCallInfoBuffer
- I TBasicCallControl
- Connect
- Answer
- Disconnect
- Hold
- SwapHold
- ParkDirect
- Unpark
- BlindTransfer
- Transfer
- I TCallStateEvent
- get_Cause
- get_State
- get_Call
- I TCallNotificationEvent
- get_Call
- I TCallInfoChangeEvent
- get_Call
- I TCallHubEvent
- get_Event
- get_Call

Notes:

- TAPI *Lite* can be used from C, C++ and Delphi. Visual Basic cannot directly use TAPI 2.1, but does support TAPI 3.0 without any third-party tools.
- TAPI *Lite* provides detailed information on telephony events, including the ability to screen-pop based on CLI and/or DDI.

Device-Specific Data

The following table shows the device specific data available via TAPI.

- Phone's extension number
- Forward on busy flag
- Forward on no answer flag
- Forward unconditional flag
- Forward hunt group flag
- Do not disturb flag
- Outgoing call bar flag
- Call waiting on flag
- Voicemail on flag
- Voicemail ring-back flag
- Number of voicemail messages
- Number of unread voicemail messages
- Outside call sequence number
- Inside call sequence number
- Ring back sequence number
- No answer timeout period
- Wrap up time period
- Can intrude flag
- Cannot be intruded upon flag
- X directory flag
- Force login flag
- Login code flag
- System phone flag
- Absent message id
- Absent message set flag
- Voicemail email mode
- User's extension number
- Users Locale
- Forward number
- Follow me number
- Absent text
- Do not disturb exception list
- Forward on busy number
- User's priority
- Number of groups the user is a member of
- Number of groups that the user is a member of that are currently outside their time profile
- Number of groups the user is currently disabled from
- Number of groups that the user is a member of that are currently out of service
- Number of groups that the user is a member of that are currently on night service

DevLink Fields

The following table shows the device specific data available via DevLink.

#	Field Data (S Message)	#	Field Data (S Message)
1	A call id	26	Voicemail disallow
2	B call id	27	Sending complete
3	A state	28	Bc.tc,bc.tm
4	B state	29	Owner hunt group name
5	A connected	30	Original hunt group name
6	A is music	31	Original user name
7	B connected	32	Target hunt group name
8	B is music	33	Target user name
9	A name	34	Target RAS name
10	B name	35	Is internal call
11	B list (possible targets for the call)	36	Time stamp
12	A slot ,channel	37	Connected time
13	B slot , channel	38	Ring time
14	Called party presentation and type	39	Connected duration
15	Called party number	40	Ring duration
16	Calling party presentation and type	41	Locale
17	Calling party number	42	Park slot number
18	Called sub address	43	Call waiting
19	Calling sub address	44	Tag
20	Dialled party type	45	Transferring
21	Dialled party number	46	Sv active
22	Keypad type	47	Sv quota used
23	Keypad number	48	Sv quota time
24	Ring attempt count	49	Account code
25	Cause	50	Unique call identifier
#	Field Data (D Message)	#	Field Data (A Message)
1	A call id	1	A call id
2	B call id	2	B call id
3	Unique call identifier	3	Unique call identifier

Chapter 19.

Technical Specifications

19. Technical Specifications

Dimensions

Unit Dimensions (mm/inches)	Width	Height	Depth
IP412 and all Expansion Modules	445mm/17.5"	71mm/2.8"	245mm/9.7"
IP500	445mm/17.5"	73mm/2.9"	365mm/14.4"

- The recommended minimum clearance, front and rear, for the connection of cables and other devices is 75mm/3".

Weight

Unit	Weight
IP500 System Unit	3.2Kg/7.0lbs
IP412 Control Unit	3.0Kg/6.7lbs
Analog 16 Module	2.9Kg/6.5lbs
DS16 Module	3.0Kg/6.7lbs
DS30 Module	3.5Kg/7.8lbs
WAN3 Module	2.8Kg/6.3lbs
So8 Module	2.8Kg/6.3lbs
Phone 8 Module	2.8Kg/6.3lbs
Phone 16 Module	2.9Kg/6.5lbs
Phone 30 Module	3.1Kg/6.94lbs

Environmental

- 0°C to +40°C (32°F to 104°F). 95% relative humidity, non-condensing.

Call Capacity

Busy Hour Call Complete (BHCC) is a measure used to test IP Office systems under a high call load. For BHCC tests, each incoming call rings for 5 seconds, is answered and stays connected for 6 seconds. The BHCC figures for the different IP Office control units are listed below. Note that in some cases the BHCC figure achievable will be limited by the number of incoming trunks supported.

- IP500 = 36000.
- IP412 = 36000.

Telephone Extension Cable Lengths

The following table details the maximum cable lengths supported for the telephone ranges. These figures assume that standard twisted-pair telephone cable or CAT5 network cable is used.

Telephone	Unshielded Twisted-Pair (UTP) - 50nf/Km			CW1308
	AWG22 (0.65mm)	AWG24 (0.5mm)	AWG26 (0.4mm)	
2400/5400 Series	1200m/3937'.	1000m/3280'.	670m/2200'.	400m/1310'.
T3 Series (Upn)	1000m/3280'.	1000m/3280'.	400m/1310'.	–
Analog Phones	1000m/3280'.	1000m/ 3280'.	400m/1640'.	800m/2620'.

Heat Dissipation

Note that the above numbers are for reference only. For practical purposes, for example the calculation of heat dissipation, it is recommended to base environmental requirements (for example air cooling or UPS ratings) on the maximum input rating of the power supplies of the planned IP Office configuration, as follows.

In order to calculate the maximum, that is worst case, amount of heat that can be generated by an IP Office system, it is assumed that all input power is converted to heat; whether from the PSU itself, the system unit, expansion module and/or cabling.

Heat dissipation is normally measured in British Thermal Units (BTU's). A heat value expressed in Watts can be converted to BTU/hr by multiplying by 3.41297. As indicated above, you should use the maximum power input of 115 VA of each power supply to calculate this most accurately.

Using the conversion factor:

- Heat Dissipation = $115 \times 3.41297 = 392.5$ BTU/hour.

The metric equivalent to BTU is a Joule where 1 BTU = 1,055 Joules.

This calculates the BTU value per power supply. The maximum BTU per system is therefore calculated, based on total number of power supplies installed in the system. For example, for a IP412, this would be 1 for the base unit and up to 12 for the expansion modules.

- IP412 Maximum Heat Dissipation = $13 \times 392.5 = 5,103$ BTU/hr.

Remember to budget for the power requirements of any additional devices that are to be co-located with the IP Office such as server PC's (voicemail, etc).

Power Supply

- Input
 - IP406 V2, IP412 and expansion modules: 2.5mm DC inlet socket. 24Vdc power input. Rating 24V DC, 2A maximum.
 - IP Office 500 System Unit: IEC AC inlet socket. 100-240V AC, 50/60Hz, 81-115VA, 2.5A maximum.

- Power Supply Units: All CE/UL/Dentori Safety Approved.
 - Standard 40W Power Supply Unit (All control and expansion units unless otherwise indicated) Supplied with the control or expansion unit. 40W PSU with integral lead to the unit. Connection to switched mains supply requires separately supplied country specific IEC 60320 C7 power cord (2-wire figure 8 connector).
 - Input: 100-240V AC, 50/60Hz, 81-115VA, 2A maximum.
 - Output: 24Vdc, 1.875A, output power 45W maximum.
 - Small Office 45W Power Supply Unit
Supplied with the unit. 45W PSU with integral lead to control unit. Connection to switched mains supply requires separately supplied country specific IEC 60320 C13 power cord (3-wire earthed cold kettle lead).
 - Input: 100-240V AC, 50/60Hz, 81-115VA, 1.5A maximum.
 - Output: 24V DC, 1.875A, output power 45W maximum.
 - IP406 V2 60W Power Supply Unit
Supplied with the control or expansion unit. 60W PSU with integral lead to the unit. Connection to switched mains supply requires separately supplied country specific IEC 60320 C13 power cord (3-wire earthed cold kettle lead).
 - Input: 100-240V AC, 50/60Hz, 81-115VA, 2.5A maximum.
 - Output: 24V DC, 1.5A, output power 60W maximum.
 - IP Office 500 80W internal Power Supply
Integral to the System Unit. Connection to switched mains supply requires separately supplied country specific IEC 60320 C13 power cord (3-wire earthed cold kettle lead).
 - Input: 100-240V AC, 50/60Hz, 81-115VA, 2.5A maximum.

Interfaces

Interface	Information
DTE Port	<ul style="list-style-type: none"> 9 way D-type D-Type female connector: V.24/V.28.
ISDN Ports	<p>EU Interfaces:</p> <ul style="list-style-type: none"> BRI: RJ45 sockets. ETSI T-Bus Interface to CTR3 for Pan European Connection. PRI E1: RJ45 socket. ETSI T-Bus Interface to CTR4 for Pan European Connection. PRI T1/J1: RJ45 socket: FCC Part 68/JATE connection. <p>USA Interfaces:</p> <ul style="list-style-type: none"> PRI T1 Service: Ground Start (GS) – Default, E&M, 56k data for 5ESS, 56/64/64 restricted for 4ESS. PRI ISDN Switch support: 4ESS, 5ESS, DMS-100, DMS-250 (includes conformance to ANSI T1.607 and Bellcore Special Report SR4287, 1992). PRI ISDN Services: AT&T Megacom 800, AT&T WATS (4ESS), AT&T SDS Accunet 56kB/s and 64kB/s (4ESS), AT&T Multiquest (4ESS).
Analog Trunk Ports	<ul style="list-style-type: none"> RJ45 sockets: Loop start/Ground start (regional dependant)
Power Fail Ports	<ul style="list-style-type: none"> RJ45 sockets:
ISDN Data Rates	<ul style="list-style-type: none"> BRI: B-channel 64kbps or 56kbps, D-channel 16kbps. PRI: B-channel 64kbps or 56kbps, D-channel 64kbps.
Analog Phone Ports	<ul style="list-style-type: none"> RJ45 sockets: CLI Schemes: DTMFA, DTMFC, DTMFD, FSK and UK20. REN: 2. (External Bell via POT port: REN = 1) Off Hook Current: 25mA. Ring Voltage: 40V (nominal) RMS.
LAN	<ul style="list-style-type: none"> RJ45 sockets. Auto-negotiating 10/100 BaseT Ethernet (10/100Mbps).
WAN	<ul style="list-style-type: none"> IP406 V2 and IP412: 37 way D-Type female sockets. X.21 interface to 2048k bps, V.35 interface to 2048Kbps and V.24 Interface to 19.2Kbps.
Audio	<ul style="list-style-type: none"> 3.5mm Stereo Jack socket. Input impedance - 10k /channel. Maximum AC signal – 200mV rms.
External Output Port	<ul style="list-style-type: none"> 3.5mm Stereo Jack socket. Switching Capacity - 0.7A. Maximum Voltage - 55V DC. On state resistance - 0.7. Short circuit current - 1A. Reverse circuit current capacity - 1.4A.
Embedded Voice Memory	<ul style="list-style-type: none"> IP406 V2 and IP500: 512MB Compact Flash memory card.

Protocols

Protocol	RFC	Information
V120	-	A standard Rate Adaptation mechanism.
V110	-	A standard Rate Adaptation mechanism.
PPP	RFC1661	Point to Point Protocol.
LCP	RFC1570	Link Control Protocol.
MP	RFC1990	Multi-Link (Point to Point) Protocol.
IPCP	RFC1332	Internet Protocol Control Protocol.
PAP	RFC1334	Password Authentication Protocol.
RTP/RTCP	RFC1889	Real Time and Real Time Control Protocol.
CHAP	RFC1994	Challenge Handshake Authentication Protocol.
CCP	RFC1962	Compression Control Protocol.
STAC	RFC1974	STAC LZS Compression Protocol.
MPPC	RFC2118	Microsoft Point to Point Compression (Protocol).
BACP	RFC2125	Bandwidth Allocation Control Protocol.
UDP	RFC768	User Datagram Protocol.
IP	RFC791	Internet Protocol.
TCP	RFC793	Transmission Control Protocol.
DHCP	RFC1533	Dynamic Host Control Protocol.
NAT	RFC1631	Network Address Translation.
BOOTP	RFC951	Bootstrap Protocol.
TFTP	RFC1350	Trivial File Transfer Protocol.
NTP	RFC868	Network Time Protocol.
SNMPv1	RFC1157	Simple Network Management Protocol. (STD15)
	RFC1155	Structure and identification of management information for TCP/IP based internets. (STD16)
	RFC1212	Concise MIB Definitions. (STD16)
	RFC1215	A convention for defining traps for use with SNMP.
MIB-II	RFC1213	Management Information base for network management of TCP/IP based internets: MIB-II. (STD17)
ENTITY MIB	RFC2737	Entity MIB (Version 2).
RIP	RFC1058	Routing Information Protocol.
	RFC2453	RIP Version 2. (STD56)
	RFC1722	RIP Version 2 Protocol Applicability Statement. (STD57)
IPSec	RFC2401	Security Architecture for the Internet Protocol.
	RFC2402	IP Authentication Header.
	RFC2403	The Use of HMAC-MD5-96 within ESP and AH.
	RFC2404	The Use of HMAC-SHA-1-96 within ESP and AH.
	RFC2405	The ESP DES-CBC Cipher Algorithm with Explicit IV.
	RFC2406	IP Encapsulation Security Payload. (ESP)
	RFC2407	The Internet IP Security Domain of Interpolation for ISAKMP.
	RFC2408	Internet Security Association and Key Management Protocol.
	RFC2409	The Internet Key Exchange.
	RFC2410	The NULL Encryption Algorithm and its Use with IPSec.
	RFC2411	IP Security Document Roadmap.
L2TP	RFC2661	Layer Two Tunneling Protocol "L2TP".
	RFC3193	Securing L2TP using IPSec.
Header Compression	RFC2507	IP Header Compression (IPHC).
	RFC2508	Compressing IP/UDP/RTP Headers for Low-Speed Serial Links.
	RFC2509	IP Header Compression over PPP.
DiffServ	RFC2474	Definition of the Differentiated Services Field (DS Field) in the IPv4 and IPv6 Headers.
PPP MP	RFC1990	The PPP Multilink Protocol (MP).
Frame Relay Encapsulation	RFC1490	Multi protocol Interconnect over Frame Relay.

Protocol	RFC	Information
ML-PPP	RFC2686	The Multi-Class Extension to Multi-Link PPP.

Session Initiation Protocol

- Rec. E.164 [2] - ITU-T Recommendation E.164: The international public telecommunication numbering plan
- RFC 2833 [7] - RTP Payload for DTMF Digits, Telephony Tones and Telephony Signals
- RFC 3261 [8] - SIP: Session Initiation Protocol
- RFC 3263 [10] - Session Initiation Protocol (SIP): Locating SIP Servers
- RFC 3264 [11] - An Offer/Answer Model with Session Description Protocol (SDP)
- RFC 3323 [14] - A Privacy Mechanism for the Session Initiation Protocol (SIP)
- RFC 3489 [18] - STUN - Simple Traversal of User Datagram Protocol (UDP) Through Network Address Translators (NATs)
- RFC 3824 [24] - Using E.164 numbers with the Session Initiation Protocol (SIP)
- RFC 1889 – RTP
- RFC 1890 - RTP Audio
- RFC 4566 – SDP
- RFC 3265 - Event Notification
- RFC 3515 - SIP Refer
- RFC 3842 - Message Waiting
- RFC 3310 – Authentication
- RFC 2976 – INFO
- RFC 3323 - Privacy for SIP (PAI) and draft-ietf-sip-privacy-04 (RPID)

PC Specification

Server Applications Dependencies

Applications	Minimum PC Resources	Intel Pentium	Intel Celeron	AMD	Notes
VoiceMail Pro Standalone	256MB RAM	Any - 1.4GHz clock speed	Any - 1.7GHz clock speed	Any - 1.4GHz clock speed	To avoid replacing the server when adding new applications we recommend that a Pentium 4 2.8GHz (or equivalent) is used when possible
VoiceMail Pro + IMS Campaign Manager	512MB RAM	Pentium 4 2.8GHz clock speed	Not tested	Athlon XP 3000+ All Athlon 64 chips are supported	
VoiceMail Pro + IVR TTS	512MB RAM Min 20GB drive	Pentium 4 2.8GHz clock speed	Not tested	Athlon XP 3000+ All Athlon 64 chips are supported	If the database being queried is located on the VM Pro server the query speed of the database will be affected by the amount of memory available. Please take into account the memory requirements of the database being queried.
VoiceMail Pro + ContactStore	512MB RAM	Pentium 4 2.8GHz clock speed	Not tested	Athlon XP 3000+ All Athlon 64 chips are supported	
VoiceMail Pro + Compact Contact Center V5	512MB RAM Min10GB drive	Pentium 4 2.8GHz clock speed	Not tested	Athlon XP 3000+ All Athlon 64 chips are supported	VM Pro and CCC can be run on the same server up to a maximum of 25 agents, 8 ports of VM Pro.
Customer Call Reporter	2GB RAM	D945 Dual Core	Not tested	AMD Athlon 64 4000+	Also requires MS-SQL 2005.
Compact Contact Center Standalone	512MB RAM	Any - 1.4GHz clock speed	Any - 1.7GHz clock speed	Any - 1.4GHz clock speed	
one-X Portal for IP Office	2GB RAM 10GB free disk space	D945 Dual Core	Not tested	AMD Athlon 64 4000+	
Delta Server (SMDR)	256MB RAM Min 10GB free disk space. IE5.5 or higher	Any - 1.4GHz clock speed	Any - 1.7GHz clock speed	Any - 1.4GHz clock speed	The Delta Server and CBC can be installed on either the same PC or on separate PC's. In both cases these are the minimum PC specifications.

Key:

- VM Pro – VoiceMail Pro
- IMS – Integrated Messaging Pro
- CM – Campaign Manager
- TTS – Text To Speech
- IVR – Third Party Database Access
- CCC – Compact Contact Center

Client Applications Dependencies

Applications	Min PC Resources	Intel Pentium	Intel Celeron	AMD	Notes
Conferencing Web Client	Internet Explorer 6 or above	ANY	ANY	ANY	Any desktop machine can be used as long as it is capable of running IE6
Phone Manager Lite/Pro	64MB RAM and 50Mb of free disk space	266Mhz			A sound card is needed if audio features are required.
SoftConsole	64MB RAM with 1GB of free disk space	Pentium II 400MHz clock speed	Celeron 2 533Mhz clock speed	Athlon B 650MHz clock speed	A maximum of four SoftConsole applications can be run per system (a license controls the number of simultaneous SoftConsole users). A sound card is needed if audio features are required.
ContactStore Web client	Internet Explorer 5 or above	ANY	ANY	ANY	Any desktop machine can be used as long as it is capable of running IE5
IP Office Manager	64MB RAM and 50Mb of free disk space	266Mhz			
IP Office SSA	256MB RAM and 50Mb of free disk space	1Ghz			Requires Java Virtual Machine 1.4.2 or later. Each SSA session takes about 35M of RAM.
Contact Center View (CCV)	128MB RAM and 10GB of free disk space	Pentium III 800MHz clock speed	Celeron 3 800Mhz clock speed	Athlon B 650MHz clock speed	For OS of Windows XP, minimum RAM increases to 256MB
CCC Reporter	Internet Explorer 6 or above	ANY	ANY	ANY	
Wallboard Server	128MB RAM and 10GB of free disk space	Any - 1.4GHz clock speed	Any - 1.7GHz clock speed	Any - 1.4GHz clock speed	The Wallboard Server MUST reside on the same PC as the Delta Server
Wallboard Client	128MB RAM and 10GB of free disk space	Pentium III 800MHz clock speed	Celeron 3 800Mhz clock speed	Athlon B 650MHz clock speed	For OS of Windows XP, minimum RAM increases to 256MB
PC Wallboard	128MB RAM and 10GB of free disk space	Pentium III 800MHz clock speed	Celeron 3 800Mhz clock speed	Athlon B 650MHz clock speed	For OS of Windows XP, minimum RAM increases to 256MB

Windows Operating System Support

The following table gives a summary of the Server & Client Operating Systems (OS) on which various IP Office applications are tested and supported for IP Office Release 6.

Microsoft Server OS ^{1,2}	IP Office Manager	SSA	VM Lite	VM Pro ³	TAPI (3rd party/WAV)	SMD R ⁴	CCC V5 Server	Conf. Center Server	Customer Call Reporter	one-X Portal
2003 Server (SP2)	Yes	Yes	Yes	Yes	Yes	Yes	Yes	Yes	Yes	Yes
XP Professional (SP3)	Yes	Yes	Yes	Yes	Yes	Yes	No	No	No	No
XP Professional (SP3) 64bit ⁵	No	No	No	No	No	No	No	No	No	No
2008 Server	Yes	Yes	No	Yes	No	Yes	No	No	No	Yes
2008 Server 64bit	Yes	Yes	No	Yes	No	Yes	No	No	No	Yes

Microsoft Client OS 1	IP Office Manager	SSA	CCC Clients	VM Lite	VM Pro ³	Soft Console	Phone Manager	TAPI (1st party)	Conf. Center Client
XP Professional (SP3)	Yes	Yes	Yes	Yes	Yes	Yes	Yes	Yes	Yes
XP Professional (SP3) 64bit ⁵	No	No	No	No	No	No	No	No	No
Vista Business/Enterprise (SP1)	Yes	Yes	Yes	Yes	Yes	Yes	Yes	Yes	Yes
Vista Ultimate (SP1)	Yes	Yes	Yes	Yes	Yes	Yes	Yes	Yes	Yes
Vista Business/Enterprise 64bit ⁵	No	No	No	No	No	No	No	No	No
Vista Ultimate 64bit ⁵	No	No	No	No	No	No	No	No	No

Non OS Applications	IMS ⁶	UMS web voicemail	Phone Manager	CCC V5 Reporter & Database	Conf. Center Client	Contact Store Database
Microsoft Exchange 2003	Yes	n/a	n/a	n/a	n/a	n/a
Microsoft Exchange 2007	No	n/a	n/a	n/a	n/a	n/a
Microsoft Outlook 2003	Yes	n/a	Yes	n/a	n/a	n/a
Microsoft Outlook 2007	Yes	n/a	Yes	n/a	n/a	n/a
Internet Explorer 6	n/a	Yes	n/a	Yes	Yes	n/a
Internet Explorer 7	n/a	Yes	n/a	Yes	Yes	n/a
Microsoft MSDE 2000	n/a	n/a	n/a	Yes	n/a	Yes
Microsoft SQL2005	n/a	n/a	n/a	Yes	n/a	No
Microsoft SQL2008	n/a	n/a	n/a	No	n/a	No

Notes:

- Windows ME, Windows 95, Windows 98, Windows NT4 and Windows 2000 operating systems are no longer supported by Avaya. They may function but have not been tested with IP Office Release 6 and any faults reported will not be fixed.
- Windows Small Business Server 2003 is supported for the same applications as Windows 2003 Server.
- Exceptions for VoiceMail Pro support:
 - Integrated Messaging Pro (IMS) does not work on Windows Server 2008 or Windows Vista.
 - Web Campaigns does not work on Windows Vista.
 - Voicemail web access does not work on Windows XP or Windows Vista.
 - Please refer to the Voicemail Installation and Administration manual.
- Although a server application, IP Office SMDR (Delta Server) can also run on a Windows 2003, Windows XP and Windows Vista client Operating Systems (32-bit only) but should not be run on the same PC as a CCC Delta Server.
- 64 Bit versions of Microsoft client operating systems are not currently supported by IP Office applications.
- Integrated Messaging Pro (IMS) does not support IMS operation with Outlook 2003/2007 operating in cache mode.
- Microsoft Exchange 2000 is no longer.

Chapter 20.

Licenses

20. Licenses

Many solutions, applications and features on IP Office systems are licensed and only operate when a valid license is detected. This includes features within IP Office applications running on PCs connected to the IP Office system.

Licenses are 32 character strings derived from a unique serial number for the IP Office system which will be using the license. The unique serial number is taken from the Feature Key device fitted to the IP Office system.

- **IP500 Smart Card Feature Key**
For IP500 IP Office control units, the serial number is based on the Smart Card Feature Key fitted to the control unit. A Smart Card Feature key is mandatory on all IP500 control units for correct operation of the unit regardless of whether the unit is using any licenses.
- **IP500 V2 SD Card Feature Key**
For IP500 V2 control units, the serial number is based on the System SD Card Feature Key fitted to the control unit. A System SD Card Feature key is mandatory on all IP500 V2 control units for correct operation of the unit regardless of whether the unit is using any licenses.

There are three types of System SD card available, which defines the default operating mode:

- System SD CARD A-LAW
- System SD CARD MU-LAW
- System SD CARD PARTNER

For licensing each IP Office control unit must have its own Feature Key and licenses. The Feature Key associated with one IP Office system cannot be used to validate the licenses of another IP Office system.

Since licenses are based on the serial number of the Feature Key, they cannot be moved between systems with different Feature Keys. If a Feature Key is lost the license will become invalid. If it is necessary to exchange a Feature Key due damage or upgrade then the existing key and licenses can be exchanged (license swap) through the Avaya Direct International (ADI) website (<https://adi.avaya.com>). Please contact your Avaya Distributor or Avaya Channel Account Manager (CAM) for more information.

Some licenses enable a number of ports, channels or users. Depending on the particular license, each supported instance may be consumed either when it is configured for use or alternatively when it is actually being used. When no further instances of a license are available, further use of the licensed feature is not allowed.



Typically for port, channel and user licenses, multiple licenses can be added to give a higher number of supported ports, channels or users. However licenses above the capacity supported by the particular IP Office control unit will not work.

The following sections detail the current individual IP Office licenses. The actual licenses are indicated by a  icon and the following information:

-  License Name in IP Office Configuration: *Avaya orderable part name (Material Code)*
License description.

IP Office Upgrade License

From Release 6 onwards IP Office needs a valid Release Entitlement to run. For new IP500 V2 systems the Release Entitlement will be free of charge delivered with the SD Card. To upgrade an older IP Office system to Release 6 an Upgrade license is required.

-  Upgrading from R5 or earlier to Release 6 – up to 32 users: *IPO LIC UPG R6.0 SML (229421)*
Single control unit with no external expansion modules.
-  Upgrading from R5 or earlier to Release 6 – more than 32 users: *IPO LIC UPG R6.0 (229420)*
-  Allows any Release from 6.x to 10.x inclusive to run: *IPO LIC UPG R6 TO R10 (229422)*

IP Office Group Collaboration Licenses

IP Office Preferred Edition

The following license is supported on all current IP Office control units.

- Preferred Edition: *IPO LIC PREFRD (VM PRO) RFA LIC:DS (171991)*
In particular, this license enables:

- advanced messaging
- multi-level automated attendant
- secure meet-me conferencing
- call recording
- conditional call routing
- Text to Speech (TTS) for e-mail reading for users with appropriate User profiles
- queue announcements

This system license enables VoiceMail Pro and provides the initial 4 ports. If additional voicemail ports are required, the appropriate licenses can be purchased at time of initial purchase or later (see "Additional Messaging Ports licenses" section below).

IP Office Preferred Edition Messaging (VoiceMail Pro) is a messaging server application that runs on a Windows server PC. It is enabled through the Preferred Edition license (see above). Messaging services to multiple IP Offices can be supported when they are connected in an IP Office Small Community Network (SCN). In this centralized voicemail scenario, only the central IP Office requires the Preferred Edition license. The other IP Offices within the network do not require a Preferred Edition license. However, from Release 6 onwards due to load balancing, capacity increase and resilience reasons it is possible to have more than one Preferred Edition License in the SCN.

By default Preferred Edition provides standard voicemail mailbox functions to all IP Office users and hunt groups plus support for call recording and call waiting announcements to callers. A range of additional features can be enabled by further licenses.

- Additional Messaging Ports Licenses



The Preferred Edition license includes support for 4 messaging ports. The total number of messaging ports supported can be increased by adding combinations of the following licenses, up to the maximum supported by the particular IP Office control unit (IP406 V2 = 20, IP412 = 30, IP500/IP500 V2 = 40).

- Additional Messaging (2 Ports): *IPO LIC VM PRO RFA 2 LIC:CU (174459)*
- Additional Messaging (4 Ports): *IPO LIC VM PRO RFA 4 LIC:CU (174460)*
- Additional Messaging (8 Ports): *IPO LIC VM PRO RFA 8 LIC:CU (174461)*
- Additional Messaging Pro (16 Ports): *IPO LIC VM PRO RFA 16 LIC:CU (174462)*

- Messaging Feature Licenses

The Advanced Edition license provides Customer Call Reporter, ContactStore Call Recording Library, Interactive Voice Response (IVR), Visual Basic scripting and generic Text-To-Speech (TTS). The following licenses enable specific Messaging features beyond those already provided with Advanced Edition. These additional licenses all require the Preferred Edition (Voicemail Pro) license as a pre-requisite.

- UMS Web Services Licenses (also enabled by the "Teleworker" and "Power User" licenses)
UMS (Unified Messaging Server) allows users to access the messages in their Voicemail Pro mailbox via either a web browser (requires IIS on the Voicemail Pro server), using a IMAP compatible email application or using Microsoft Exchange Server 2007 message store. The total number of users supported is set by adding combinations of the following licenses. Note that a license is consumed for each user configured for UMS access.
 - UMS Web Services - 1 User License: *IPO LIC VM PRO UMS 1 USER (217880)*
 - UMS Web Services - 5 User License: *IPO LIC VM PRO UMS 5 USER (217881)*
 - UMS Web Services - 20 User License: *IPO LIC VM PRO UMS 20 USER (217883)*
- Messaging Recordings Administrators License: *IPO LIC CONTACTSTORE RFA LIC:DS (187166)* (also included in the "Advanced Edition" license)
As standard, Preferred Edition supports automatic and or manual call recording to specified mailboxes. Also provided as part of Advanced Edition, this license allows Preferred Edition to use a 3rd-party application to support the storage and administration of call recordings. Currently the supported application for this is ContactStore for IP Office. When used manual and or automatic records calls can be routed (along with the call details) to the ContactStore applications database for storage and retrieval when required.
- Text to Speech (TTS) Licenses
TTS can be used within customized voicemail call flows to speak information to callers rather than having to record prompts for the call flow or speak results of IVR queries. Two options are supported for TTS operation:

- As part of the Advanced Edition, that enables the use of the default Text-To-Speech (TTS) speech engine supplied as part of Windows operating system or any other SAPI compliant speech engine. This allows the creation of automated call flows that speak results of IVR queries. Eight (8) licenses are provided with the Advanced Edition system license.
-  Messaging TTS (ScanSoft) License: *IPO LIC AVAYA TTS RFA 1 LIC:CU (182299)*
This license enables the use of the TTS speech engines supplied as part of the IP Office Voicemail Pro software set. Multiple licenses can be combined for the number of simultaneous uses of TTS required up to the number of voicemail channels licensed.
-  Networked Messaging License: *IPO LIC NTWKD MSGING RFA LIC:DS (182297)*
Voicemail Pro Networked Messaging (VPNM) can be used between separate IP Office systems, each with their own Voicemail Pro server, to exchange messages left for different mailboxes. This option is not supported within a Small Community Network (SCN) but can be used between separate SCN networks.

IP Office Advanced Edition (Release 6 onwards)

-  Advanced Edition: *IPO LIC R6 ADV EDITION RFA LIC:DS (229424)*

In particular, this license enables:

- IP Office Customer Call Reporting (CCR),
- ContactStore Call Recording Library
- Interactive Voice Response (IVR) with external databases
- Visual Basic Scripting
- 8 ports of Text-to-Speech (TTS) to allow database queries using IVR to be read over the phone.
- The Advanced Edition needs a valid Preferred Edition license as a pre-requisite to run.

Essential Edition Additional Voicemail Ports License (IP500 V2 only)

Essential Edition provides embedded messaging does not require the presence of a license. However, from Release 6 onwards each IP500 V2 system supports Essential Edition by default with 2 ports of voicemail enabled. This can be expanded up to 6 channels through licenses in steps of two.

-  Additional Embedded Messaging (2 Ports): *IPO LIC R6 ESSNTL EDITION ADD 2 (229423)*

IP Office User Profile Licenses

The following chart shows an overview of the functions of each User Profile.

User Profile	Functionality Enabled								
	Mailbox	Mobility	one-X Portal for IP Office	Softphone	Unified Messaging	Text-to-Speech (Generic) for email reading	Soft Console	CCR Agent	CCR Supervisor
Basic User	✓								
Teleworker	✓		✓						
Office Worker	✓		✓		✓				
Mobile User	✓	✓				✓			
Power User	✓	✓	✓	✓	✓	✓			
Add ons									
Receptionist							✓		
Customer Service Agent								✓	
Customer Service Supervisor									✓

Basic User

This functionality would be suitable for common areas (e.g. meeting rooms) or users with less communication needs. A basic user has all basic core functions enabled, including mailbox and VPN phone usage. This is the default functionality for users on the system when no licenses are applied.

Mobile Worker

This User Profile is targeted at users with mobile devices and no internet connection to the office, e.g. field sales and service staff who are often on the road. They are provided with functions such as one number access and call control as if "in the office", enabling them to never miss a call.

The Mobile Worker license enables a user to be configured to use the IP Office Mobility features. Those features include Mobile Twinning, Mobile Call Control (IP500 only), one-X Mobile Client (IP500 only) and use of Text to Speech (TTS) for listening to your emails remotely. The license instances are consumed by a user being configured for any mobility feature.

Release 5 only

- 📞 Mobile Worker License - 1 User: *IPO LIC MOBILE WORKER RFA 1 (195569)*
- 📞 Mobile Worker License - 5 Users: *IPO LIC MOBILE WORKER RFA 5 (195570)*
- 📞 Mobile Worker License - 20 Users: *IPO LIC MOBILE WORKER RFA 20 (195572)*

Release 6 onwards

- 📞 Mobile Worker License - 1 User: *IPO LIC R6 MOBILE WORKER 1 (229434)*
- 📞 Mobile Worker License - 5 Users: *IPO LIC R6 MOBILE WORKER 5 (229435)*
- 📞 Mobile Worker License - 20 Users: *IPO LIC R6 MOBILE WORKER 20 (229436)*

Office Worker

This User Profile is targeted at users who are working in the office. In conjunction with a wired or wireless Avaya Phone, they are provided with functions to control their communication with a PC e.g. control audio conferences or enabling them to control the voicemails with an e-mail client (this requires Preferred Edition).

The Office Worker license enables a user to use Unified Messaging Service (UMS) and one-X Portal for IP Office (without Telecommuter functionality). The license instances are consumed for each user being configured.



- 📞 Office Worker License - 1 User: *IPO LIC R6 OFF WORKER RFA 1 (229438)*
- 📞 Office Worker License - 5 Users: *IPO LIC R6 OFF WORKER RFA 5 (229439)*
- 📞 Office Worker License - 20 Users: *IPO LIC R6 OFF WORKER RFA 20 (229440)*

Teleworker

This User Profile is targeted at users who are working from home (or elsewhere) with Internet connection to the office. They are provided with the ability to leverage the PSTN/ISDN via Telecommuter mode, without incurring any remote phone charges. Alternatively the new IP Office Softphone can be used if the quality of service of the local internet connection is adequate.

The Teleworker license enables a user to use one-X Portal for IP Office and the IP Office Video Softphone. UMS functionality for voicemail/email integration is also enabled, providing synchronization with any IMAP e-mail client (this requires Preferred Edition). The license instances are consumed for each user being configured.

Release 6 onwards



-  Teleworker License - 1 User: *IPO LIC R6 TELEWORKER 1 (229430)*
-  Teleworker License - 5 Users: *IPO LIC R6 TELEWORKER 5 (229431)*
-  Teleworker License - 20 Users: *IPO LIC R6 TELEWORKER 20 (229432)*

Power User

This User Profile is targeted at key knowledge workers with the need for both Mobile Worker and Teleworker functionality.

The Power User license enables a user to use one-X Portal for IP Office, Softphone, all Mobility features and Unified Messaging Service (UMS). The license instances are consumed for each user being configured.

Release 6 onwards

-  Power User License - 1 User: *IPO LIC R6 PWR USER 1 (229426)*
-  Power User License - 5 Users: *IPO LIC R6 PWR USER 5 (229427)*
-  Power User License - 20 Users: *IPO LIC R6 PWR USER 20 (229428)*

Receptionist



This User profile is targeted at operators/receptionists and provides a visual PC interface for call handling and management for multiple sites. Up to 4 of these users are supported on each site.

The Receptionist license enables a user to use IP Office SoftConsole. This is a Windows PC application intended for receptionists and operators. Up to 4 SoftConsoles can be licensed on a single IP Office system.

-  Receptionist User License: *IPO LIC RECEPTIONIST RFA LIC:CU (171987)*
Enables the 1st instance and subsequent instances of the PC-based operator console. Additional licenses can be added for up to 4 SoftConsoles running at any time.

Customer Service Agent

This User Profile is targeted at employees who are responsible for fielding customer service calls. This agent license enables a user to use IP Office Customer Call Reporter. It provides them with a web browser interface to view key statistics in real-time and also allows supervisor to track their performance with IP Office Customer Call Reporter. Up to 150 agents can be licensed on IP Office Customer Call Reporter.

-  Customer Service Agent License - 1 User: *IPO LIC CUSTMR SVC AGT RFA 1 (217650)*
-  Customer Service Agent License - 5 Users: *IPO LIC CUSTMR SVC AGT RFA 5 (217651)*
-  Customer Service Agent License - 20 Users: *IPO LIC CUSTMR SVC AGT RFA 20 (217653)*

Customer Service Supervisor

This User Profile enables service supervisors to track, measure and create reports for agent (or a group of agents) productivity via a web browser interface. This supervisor license enables a supervisor to use IP Office Customer Call Reporter. Up to 30 supervisors can be licensed on IP Office Customer Call Reporter.

-  Customer Service Supervisor License - 1 User: *IPO LIC R6 CUSTMR SVC SPV 1 (229442)* @
Release 6 onwards

CCC to CCR Migration

This upgrade license will convert ALL Compact Contact Center (CCC) licenses to Customer Call Reporter (CCR). This includes all supervisors and agents.

-  CCC to CCR Upgrade License: *IPO LIC CUSTMR CUSTMR CALL REPORTER UPG LIC (217658)*

Phone Manager Licenses

IP Office Phone Manager is a legacy Windows PC application that allows IP Office users to control their telephone through their PC. An optional IP Softphone is also available with additional licensing. In Release 6, it is recommended to use one-X Portal for IP Office and the new IP Office Softphone (using Teleworker or Power User licenses) instead of Phone Manager Pro.

- Phone Manager Pro License
These licenses control how many users configured for Phone Manager Pro can simultaneously run Phone Manager in that mode. Multiple licenses can be combined.
 -  Phone Manager Pro (per seat) - 1 User: *IPO LIC PMGR PRO RFA 1 LIC:CU (177468)*

- Phone Manager Softphone Licenses

These licenses control how many users configured for Phone Manager Pro PC Softphone can simultaneously run Phone Manager in that mode. Note that running Phone Manager in this mode also requires and consumes a Phone Manager Pro license for each user.

-  Phone Manager Softphone (per seat) - 1 User: *IPO LIC PMGR SFTPHN RFA 1 LIC:CU (174462)*

IP Office 500 System Licenses



The following licenses are used to enable features for systems based on the IP500 and IP500 V2 control units.

- IP500 Universal PRI Additional Channel Licenses

The IP500 PRI Universal trunk card (IP500 PRI-U) is available in 1 or 2 port variants, each port supporting a single PRI trunk connection. Through the IP Office configuration the ports can be switched between supporting E1, E1R2 or T1 line types as required for the trunk being connected. Each port supports 8 B-channels ("Bearer") which do not need to be licensed. If additional B-channels are required, they must be licensed through the addition of the licenses below. Multiple licenses can be added to achieve the total number of channels required. D-channels are not subject to licensing. The licenses are consumed by those channels which are configured as being 'in service', in order of the installed IP500 PRI-U cards.



- IP500 Universal PRI Additional E1 Channels Licenses

These licenses are used to enable additional E1 B-channels for IP500 PRI-U cards configured for E1 operation. Each port can support up to 30 B-channels in this mode.

-  IP500 Universal PRI Additional Channels - 2 E1 Channels License: *IPO LIC IP500 E1 ADD 2CH (215183)*
-  IP500 Universal PRI Additional Channels - 8 E1 Channels License: *IPO LIC IP500 E1 ADD 8CH (215184)*
-  IP500 Universal PRI Additional Channels - 22 E1 Channels License: *IPO LIC IP500 E1 ADD 22CH (215185)*



- IP500 Universal PRI Additional E1R2 Channel Licenses

These licenses are used to enable additional E1R2 B-channels for IP500 PRI-U cards configured for E1R2 operation. Each port can support up to 30 B-channels in this mode.

-  IP500 Universal PRI Additional Channels - 2 E1R2 Channels License: *IPO LIC IP500 E1R2 ADD 2CH (215186)*
-  IP500 Universal PRI Additional Channels - 8 E1R2 Channels License: *IPO LIC IP500 E1R2 ADD 8CH (215187)*
-  IP500 Universal PRI Additional Channels - 22 E1R2 Channels License: *IPO LIC IP500 E1R2 ADD 22CH (215188)*

- IP500 Universal PRI Additional T1 Channel Licenses





These licenses are used to enable additional T1 B-channels for IP500 PRI-U cards configured for T1 PRI or T1 robbed-bit operation. Each port can support up to 23 B-channels (T1 PRI) or 24 B-channels (T1 robbed bit) in these mode.

-  IP500 Universal PRI Additional Channels - 2 T1 Channels License: *IPO LIC IP500 T1 ADD 2CH (215180)*
-  IP500 Universal PRI Additional Channels - 8 T1 Channels License: *IPO LIC IP500 T1 ADD 8CH (215181)*
-  IP500 Universal PRI Additional Channels - 32 T1 Channels License: *IPO LIC IP500 T1 ADD 32CH (215182)*

- IP500 Voice Compression Module Licenses

The Voice Compression Module (Channel) Licenses are not needed with Release 6 but still needed with Release 5. When upgrading a system from Release 5 to Release 6 each available VCM Channel will be automatically converted into 3 Avaya IP Endpoint licenses. E.g. If a customer has a VCM32 Module which enables 4 VCM channels plus a 8 Channel License, then this will be converted into 36 Avaya IP Endpoint licenses.

Up to 2 IP500 VCM cards can be fitted into an IP500 control unit. The card is available in two variants, supporting up to 32 or 64 VCM channels. Each card provides 4 VCM channels that do not need to be licensed. Additional VCM channels up to the maximum capacity of the cards fitted can be enabled by the addition of the licenses below. Multiple licenses can be added to achieve the total number of channels required. Note that the maximum achievable number of channels is also affected by the codec being used. The following are not needed for Release 6, but if present will automatically be converted into derived Avaya IP Phone licenses at the rate of 3 phone licenses per VCM channel.

-  IP500 VCM Channels - 4 Channels License: *IPO LIC IP500 VCM LIC 4 CH (202961) – removed for Release 6*
-  IP500 VCM Channels - 8 Channels License: *IPO LIC IP500 VCM LIC 8 CH (202962) – removed for Release 6*
-  IP500 VCM Channels - 16 Channels License: *IPO LIC IP500 VCM LIC 16 CH (202963) – removed for Release 6*
-  IP500 VCM Channels - 28 Channels License: *IPO LIC IP500 VCM LIC 28 CH (202964) – removed for Release 6*
-  IP500 VCM Channels - 60 Channels License: *IPO LIC IP500 VCM LIC 60 CH (202965) – removed for Release 6*

- IP500 Voice Networking Licenses





The use of private voice networking trunks between IP500 control units and other systems requires voice networking channel licenses within the IP500. This applies to H323 IP trunks configured on the IP500 including IP trunks being used for an IP Office Small Community Network (SCN). A voice networking license is also required for the use of trunks configured to for QSIG operation. On H323 IP trunk, a license instance is consumed for each simultaneous outgoing call (incoming calls do NOT consume a license). On QSIG trunk, the number of calls is limited by the trunk type rather than available licenses.

-  IP500 Voice Networking (Additional Channels) License: *IPO LIC IP500 VCE NTWKG ADD 4 LIC:CU (205650)*

This license enables 4 voice networking channels including the Advanced Networking features (distributed groups and hot-desking across Small Community Network). Additional licenses can be added to achieve the number of voice networking channels required.







SIP Trunk Channel Licenses

These licenses are used to enable channels on SIP trunks added to the IP Office system. When a channel is used it requires a license. Multiple licenses can be combined for the total number of channels required. Note that SIP calls will require VCM channels during call setup and may require VCM channels during the call.





-  SIP Trunk Channels - 1 Channel: *IPO LIC SIP TRNK RFA 1 (202967)*
-  SIP Trunk Channels - 5 Channels: *IPO LIC SIP TRNK RFA 5 (202968)*
-  SIP Trunk Channels - 10 Channels: *IPO LIC SIP TRNK RFA 10 (202969)*
-  SIP Trunk Channels - 20 Channels: *IPO LIC SIP TRNK RFA 20 (202970)*

IP Endpoint Licenses

With Release 6 all IP endpoints (Avaya IP endpoints as well as 3rd party IP endpoints) will require an endpoint license. There are two different types of licenses available

















- Avaya IP Endpoint License – required for all Avaya Endpoints such as 1600, 5600, 9600 and DECT 3720/25.
- 3rd Party IP Endpoint License – this is a renaming of the IP End Point License and is required for all 3rd party SIP and H.323 endpoints.
- For each IP500 VCM32 and IP500 VCM64 card installed in the system, the 4 unlicensed VCM channels previously provided by each card are converted to allow unlicensed support of 12 Avaya IP phones.
- Avaya IP Endpoint Licenses
All Avaya IP phones (including DECT and Wi-Fi phones) require an Avaya IP Endpoint license and will consume one instance of that license. Note this does not apply to the Avaya IP Office Softphone.
 -  Avaya IP Endpoint License - 1 Phone: *IPO LIC R6 AV IP ENDPOINT 1 LIC:CU (229444)*
 -  Avaya IP Endpoint License - 5 Phones: *IPO LIC R6 AV IP ENDPOINT 5 LIC:CU (229445)*
 -  Avaya IP Endpoint License - 20 Phones: *IPO LIC R6 AV IP ENDPOINT 20 LIC:CU (229447)*
- 3rd Party IP Endpoint Licenses
Non-Avaya IP phones (SIP or H.323 devices) require a 3rd Party IP Endpoint license to register to IP Office and will consume one instance of that license. Note that Avaya cannot guarantee operation beyond making and receiving calls.
 -  IP Endpoint License - 1 Phone: *IPO LIC IP40 IP ENDPOINT RFA 1 LIC:CU (174956)*
 -  IP Endpoint License - 5 Phones: *IPO LIC IP ENDPOINT RFA 5 LIC:CU (174957)*
 -  IP Endpoint License - 20 Phones: *IPO LIC IP ENDPOINT RFA 20 LIC:CU (174959)*

Other System Licenses

-  IPsec Tunneling License: IPO LIC IPSEC VPN RFA LIC:DS (182301)
IP Office control units can be configured to support VPN tunnels using IPsec and or L2TP. While L2TP tunnels can be configured without requiring a license, the use of IPsec tunnels requires this license. Note that IP Office VPN tunnels are not suitable terminating VPN links for Avaya VPNremote client phones.
-  Centralized Intuity Audix Voicemail License: IPO LIC ACM CENTRAL VM LIC:DS (177467)
Enables the use of a centralized Intuity Audix or Modular Messaging system for the IP Office voicemail server.
- CTI TAPI Licenses
The IP Office TAPI software can be run in two modes; 1st party or 3rd party. 1st Party mode does not require a license and allows individual users to control their phone using a TAPI compliant application on their PC. 3rd Party mode requires licenses and allows a TAPI application to control calls for any users on the IP Office.
 -  CTI Link Pro License: *IPO LIC CTI RFA LIC:DS (171988)*
This license allows the IP Office TAPI software to be run in 3rd party mode. A license is required for each server configured to run the IP Office TAPI software in 3rd party mode.
 -  WAVE User License: *IPO LIC TAPI WAV RFA 4 LIC:CU (177466)*
Applications accessing the IP Office TAPI software in 3rd party mode can also be used to stream WAV files to users. This license allows streaming to up to 4 users at any time. Multiple licenses can be combined for a higher number of user up to the maximum supported by the IP Office control unit; IP406 V2 = 20, IP412 = 30, IP500 = 40.

Trial Licenses

The following trial licenses can be requested. Each is valid for 60 days from the date of issue and can only be issued once for a particular IP Office Feature Key serial number. Apart from that restriction the trial license works the same as a full license.

-  Preferred Edition: *IPO LIC PREFERRED (VM PRO) TRIAL RFA LIC:DS (189782).*
-  Advanced Edition: *IPO LIC R6 ADV EDITION TRIAL LIC:DS (229425) à Release 6 onwards.*
-  Power User (Users): *IPO LIC R6 PWR USER 5 TRIAL LIC:CU (229429) à Release 6 onwards.*
-  Customer Service Agent: *IPO LIC CUSTMR SVC AGT RFA TRIAL 5 (227053).*
-  Customer Service Supervisor: *IPO LIC R6 CUSTMR SVC SPV 1 TRIAL (229449) à Release 6 onwards.*
-  Teleworker (Users): *IPO LIC R6 TELEWORKER 5 TRIAL:CU (229433) à Release 6 onwards.*
-  Mobile Worker (Users): *IPO LIC R6 MOBILE WORKER 5 TRIAL CU (229437) à Release 6 onwards.*
-  Office Worker (Users): *IPO LIC R6 OFF WORKER 5 TRIAL CU (229441) à Release 6 onwards.*
-  Receptionist (Users): *IPO LIC RECEPTIONIST RFA 1 TRIAL LIC:CU (189783).*
-  VMPro Networked Messaging: *IPO LIC NTWKD MSGING TRIAL RFA LIC:DS (189776).*
-  VMPro TTS (ScanSoft): *IPO LIC AVAYA TTS TRIAL RFA 1 LIC:CU (189778).*
-  Audix Voicemail: *IPO LIC ACM CENTRAL VM TRIAL LIC:DS (189786).*
-  IPsec Tunneling: *IPO LIC IPsec VPN RFA TRIAL LIC:DS (189806).*
-  SIP Trunk Channels: *IPO LIC SIP TRUNKING TRIAL RFA 5 (205820).*
-  IP500 Voice Networking: *IPO LIC IP500 VCE NTWK ADD 4 TRIAL (205823).*
-  Avaya IP End Points: *IPO LIC R6 AV IP ENDPOINT 5 TRIAL (229449) à Release 6 onwards.*
-  Third-Party IP End Points: *IPO LIC IP ENDPOINT RFA 5 TRIAL (227040).*

Licensing Examples

Some features require a combination of licenses.

Example 1: IP500 Small Community Network

Each IP500	
Required Licenses	<ul style="list-style-type: none"> IP500 Voice Networking (4 Channels).
Optional Licenses	<ul style="list-style-type: none"> IP500 Voice Networking (Additional Channels).

Example 2: Messaging in an IP500 Small Community Network

	Central IP500	Remote IP500
Required Licenses	<ul style="list-style-type: none"> IP500 Voice Networking (4 Channels). Preferred Edition (Messaging 4 Ports). 	<ul style="list-style-type: none"> IP500 Voice Networking (4 Channels).
Optional Licenses	<ul style="list-style-type: none"> IP500 Voice Networking (Additional Channels). Additional Messaging (ports). 	<ul style="list-style-type: none"> IP500 Voice Networking (Additional Channels). Preferred Edition (Messaging 4 Ports). Additional Messaging (ports).

Example 3: ContactStore Recording Library in an IP500 Small Community Network

	Central IP500	Remote IP500
Required Licenses	<ul style="list-style-type: none"> IP500 Voice Networking (4 Channels). Preferred Edition (Messaging 4 Ports). Advanced Edition or Messaging Recordings Administrator. 	<ul style="list-style-type: none"> IP500 Voice Networking (4 Channels). Advanced Edition or Messaging Recordings Administrator.
Optional Licenses	<ul style="list-style-type: none"> IP500 Voice Networking (Additional Channels). Additional Messaging (ports). 	<ul style="list-style-type: none"> IP500 Voice Networking (Additional Channels). Preferred Edition (Messaging 4 Ports). Additional Messaging (ports).

Chapter 21.

Appendix

21. Appendix

The following equipment is no longer sold by Avaya but is still supported by IP Office Release 6.

IP412 Control Unit

With a greater internal data transfer capability than the IP406 V2, the IP412 is more suitable for meeting the needs of the small contact center or businesses with a CRM focus. The IP412 differs from the IP406 V2 by providing a greater trunk expansion capability of up to four PRI trunks. The IP412 is a stackable unit with an optional 19" rack mounting kit. The IP412 includes:

- 9-pin DTE Port (for maintenance or Feature Key connection for application licensing).
- X.21/V35 WAN interface.
- Support for up to 12 IP Office Expansion Modules:
 - Phone modules (8, 16, 30)
 - Digital Station modules (16, 30)
 - Analog Trunk Module 16
 - So8 module
- External O/P socket supporting two relay on/off switch ports, e.g. for door entry systems.
- Audio input port for external music on hold source.
- Two trunk interface card slots for analog, BRI, PRI (T1, E1) or CAS (E1R2)
- 2 internal sockets for IP Telephony expansion – voice compression modules (from 4 to 30 channels)
- Internal socket for internal modem (2 or 12) for Remote Access Services
- 108 Data channels
- Up to 30 VoiceMail Pro ports
- Two 10/100 switched Ethernet ports (Layer 3).

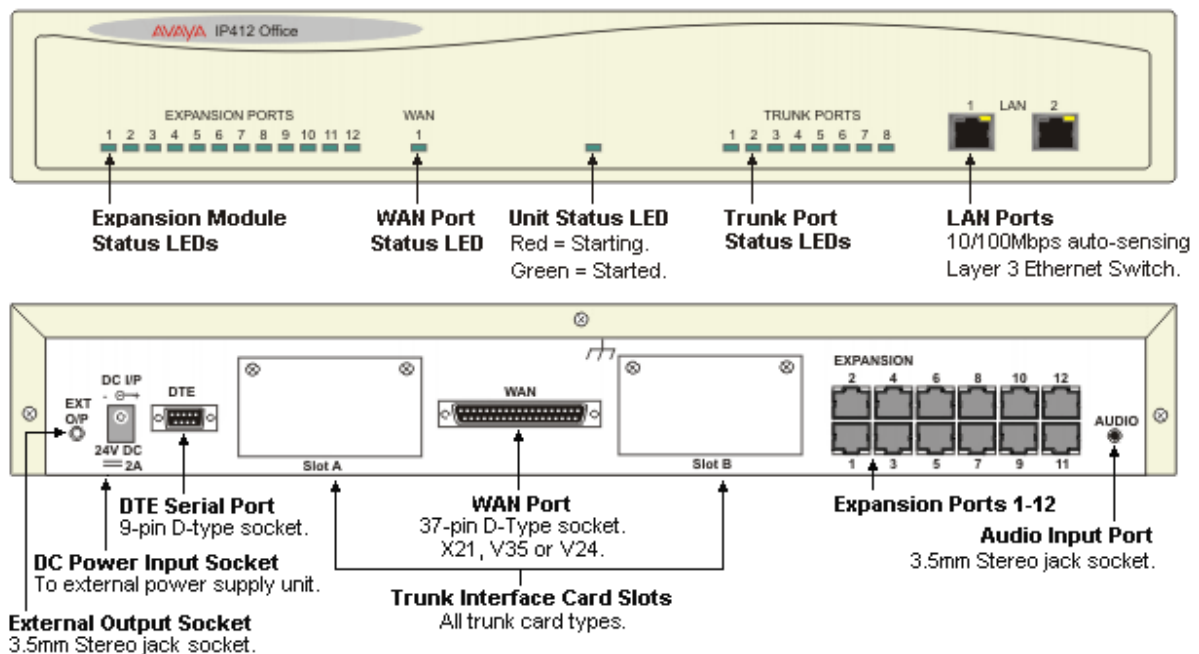

Expansion Modules

Through support of up to twelve external Expansion Modules, IP412 can be enhanced to support a mixture of analog, digital or IP phones, to maximum of 360 phones in any combination.

If additional analog trunks are required, these can be aggregated in groups of 16 on each analog expansion module.

Data Channels

A Data Channel is used for Remote Access (RAS), Internet Access, and Voicemail sessions. A data channel is an internal signaling resource used whenever a call is made from the IP network to an exchange line (Central Office). For example, four people surfing the Internet will use a single data channel since they all share the same line to the ISP. Two people remotely accessing the Office LAN from home will use two data channels since they have dialed in on separate lines. IP extensions do not use data channels. Data channels are used for voicemail connections with a maximum of 30 available for VoiceMail Pro on a IP412.

Modems and Voice Compression modules

You can add additional hardware to the IP412 system to add one modem card (12 V.90 modems) and 2 Voice Compression Modules (VCM). Each VCM supports from 4 to 30 simultaneous Voice over IP sessions and is used for either providing networking between sites over a Wide Area Network or supporting IP Telephones and Soft phones.

IP406 V2 Control Unit

The IP406 V2 control unit is a stackable unit with an optional 19" rack mounting kit. The IP406 V2 includes:

- Eight Digital Station (DS) ports for supported 2400, 4400, 5400, 6400 and T3 Series phones plus 3810 wireless (US) phones.
- Two Analog telephone ports.
 - Two Wire
 - DTMF signaling (No rotary or Loop Disconnect)
 - Timed Break Recall (No Earth Recall)
 - Caller ID capable – a variety of standards, see later
 - MWI capable – 82.5V and Line Reversal
- Eight 10/100 Mbps LAN Switched ports (Layer-2, unmanaged).
- Support for optional embedded voicemail/auto-attendant (Compact Flash card)
- 9-pin DTE Port (for maintenance or Feature Key connection for application licensing).
- X.21/V35 WAN interface.
- Support for up to 6 IP Office Expansion Modules:
 - Phone modules (8, 16, 30)
 - Digital Station modules (16, 30)
 - Analog Trunk Module 16
 - So8 module
- External O/P socket supporting two relay on/off switch ports, e.g. for door entry systems.
- Audio input port for external music on hold source.
- Two trunk interface card slots for analog, BRI, PRI (T1, E1) or CAS (E1R2)
- Internal socket for IP Telephony expansion – voice compression modules (from 4 to 30 channels)
- Internal socket for internal modem (2 or 12) for Remote Access Services
- 50 Data channels
- Up to 20 VoiceMail Pro ports

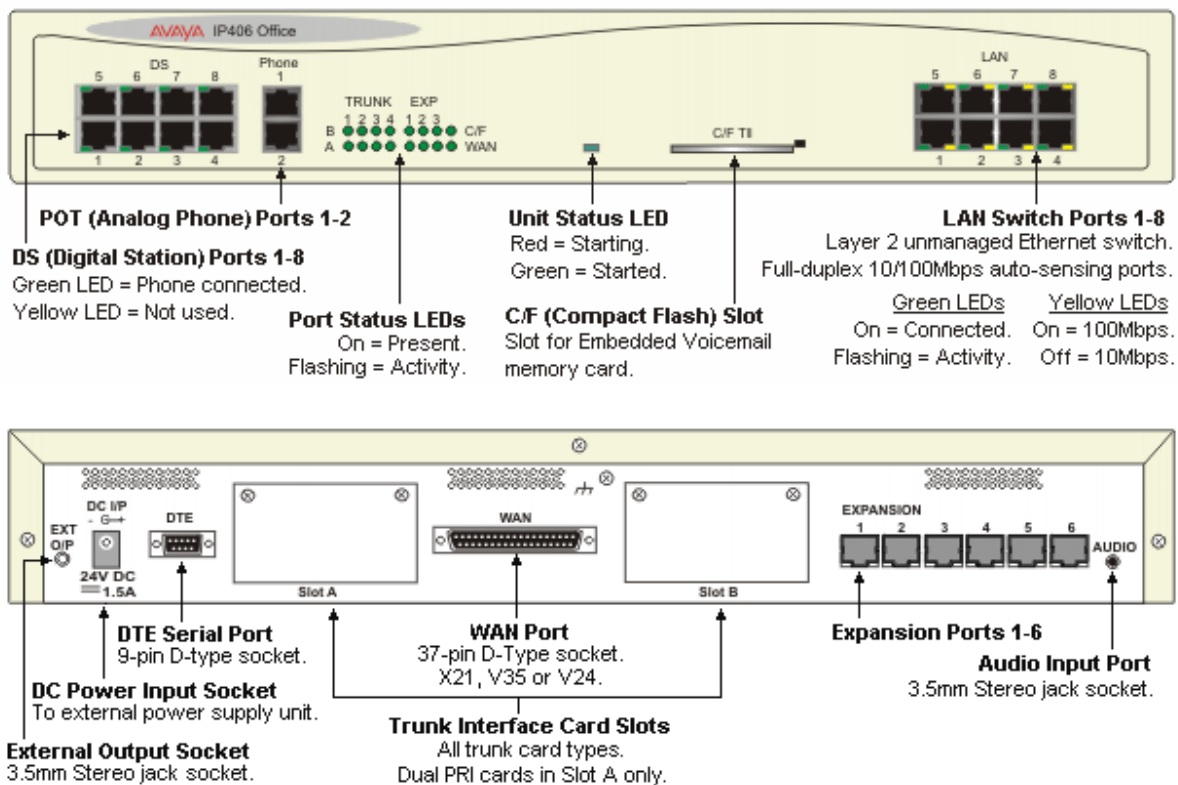

Expansion Modules

Through support of up to six external Expansion Modules, IP406 can be enhanced to support a mixture of analog, digital or IP phones, to maximum of 190 phones in any combination.

If additional analog trunks are required, these can be aggregated in groups of 16 on each analog expansion module

Data Channels

A Data Channel is used for Remote Access (RAS), Internet Access, and Voicemail sessions. A data channel is an internal signaling resource used whenever a call is made from the IP network to an exchange line (Central Office). For example, four people surfing the Internet will use a single data channel since they all share the same line to the ISP. Two people remotely accessing the Office LAN from home will use two data channels since they have dialed in on separate lines. IP extensions do not use data channels. Data channels are used for voicemail connections with a maximum of 20 available for VoiceMail Pro on an IP406 V2.

Modems and Voice Compression modules

You can add additional hardware to the IP406 system to add one modem card (2 or 12 V.90 modems) and 1 Voice Compression Module (VCM). The VCM supports from 4 to 30 simultaneous Voice over IP sessions and is used for either providing networking between sites over a Wide Area Network or supporting IP Telephones and Soft phones.

IP400 WAN3 10/100

The IP400 WAN3 10/100 module provides three WAN connections (X21, V35 or V24 via a 37way D Type socket and using an appropriate connector cable). Data rates of up to 2 Mbps are supported on each interface, the carrier providing the line dictates the actual operating speed i.e. in some territories the maximum speed may be limited to 1.544 Mbps. These WAN interfaces are identical to the single WAN connection provided as standard on the IP406 and IP412 platforms.

The IP400 WAN3 10/100 connects to the control unit through the Local Area Network via a 10/100Mbps connection and does not use an expansion port on the control unit. IP500 does not support the WAN3 10/100. All other platforms support up to two WAN3 10/100 modules.

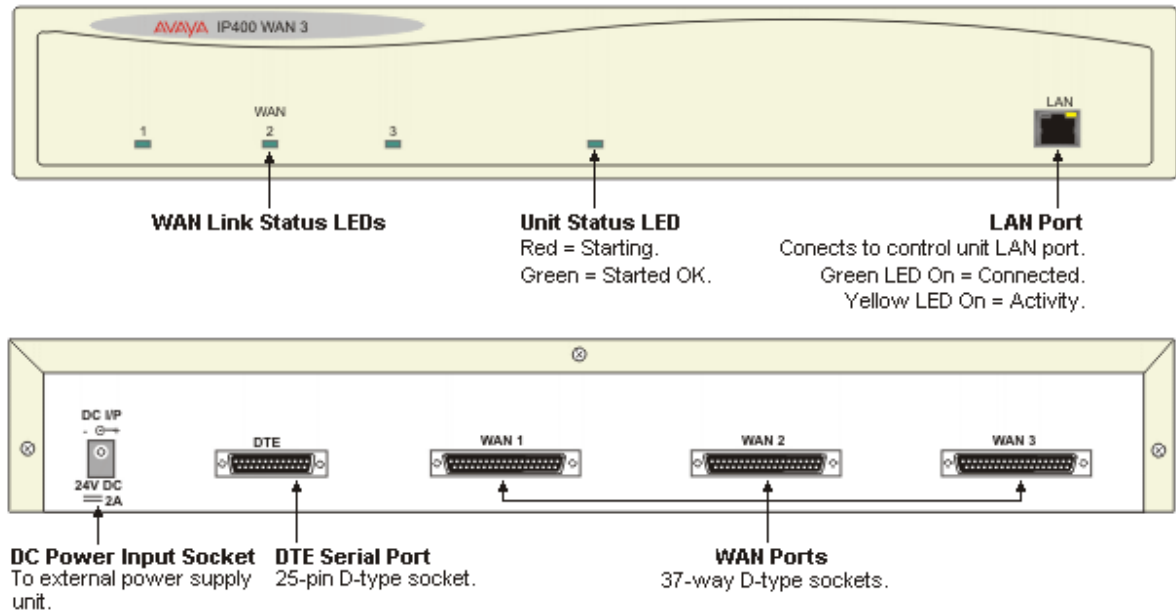

IP400 So8 Expansion Module

The IP400 So8 module provides 8 S-Bus interfaces for Basic Rate ISDN devices, such as video conferencing, fax servers or ISDN telephones.

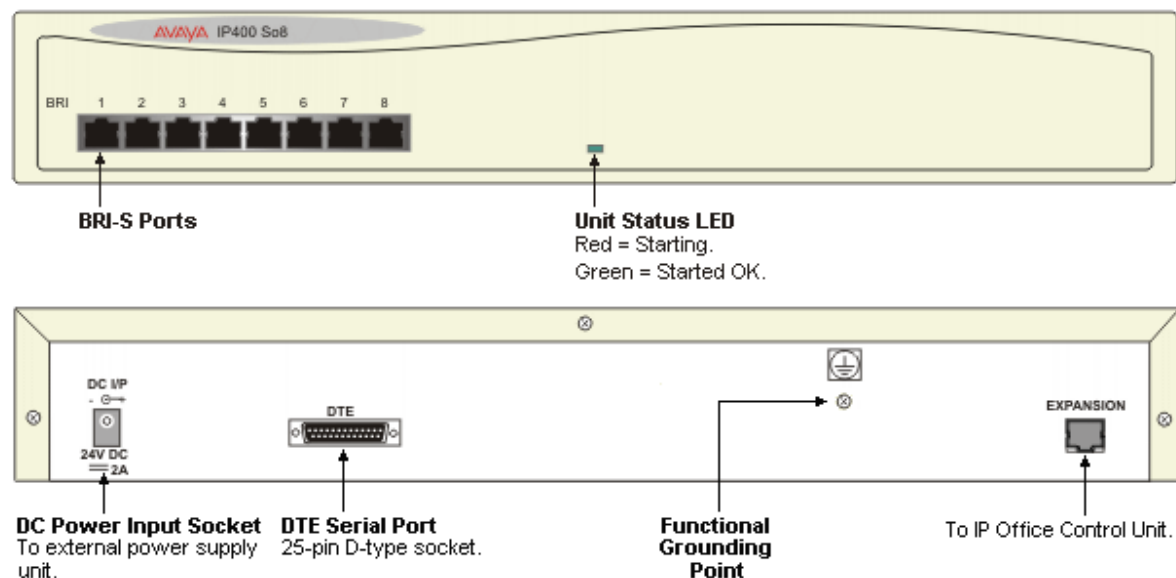

The IP Office So8 expansion module supports both point-to-point and point-to-multipoint connections. A maximum of 10 terminal endpoints identifiers (TEIs) are supported on each bus.

Small Office Edition

The IP Office - Small Office Edition is the entry level control unit of the IP Office solution and is delivered in a compact configuration that provides a mix of Analog trunks, Analog and Digital extensions and Voice over IP (VoIP) capacity. Dependant on the model chosen, up to a maximum of 28 extensions can be supported (4 Analog, 8 Digital and 16 IP).

All IP Office - Small Office Edition's variants have a four-port Layer 2 Ethernet Switch and a dedicated switched Ethernet WAN port (Layer 3), making the system ideal for connection to local area networks and broadband wide area network services such as ADSL and Cable. With Voice over IP as standard and optional IPSec security, the system can be quickly configured to provide secure voice and data networking from remote offices or branch locations back to a head office over a broadband connection.

The IP Office - Small Office Edition includes a WAN option slot on the rear of the unit which can be used to support other network connection types such as V35, V24, X21 and T1 leased lines.

The back of the unit also features a twin PCMCIA socket that can support a plug-in voice memory card for use with the embedded voicemail function, and a Wireless LAN card when using the system as an Access Point.

To enable licensed IP Office applications, a serial Feature Key can be attached directly to the IP Office - Small Office Edition removing the need for an external PC for license verification.

For resilience, under power fail conditions Analog trunk port 2 is connected to POT extension port 1.

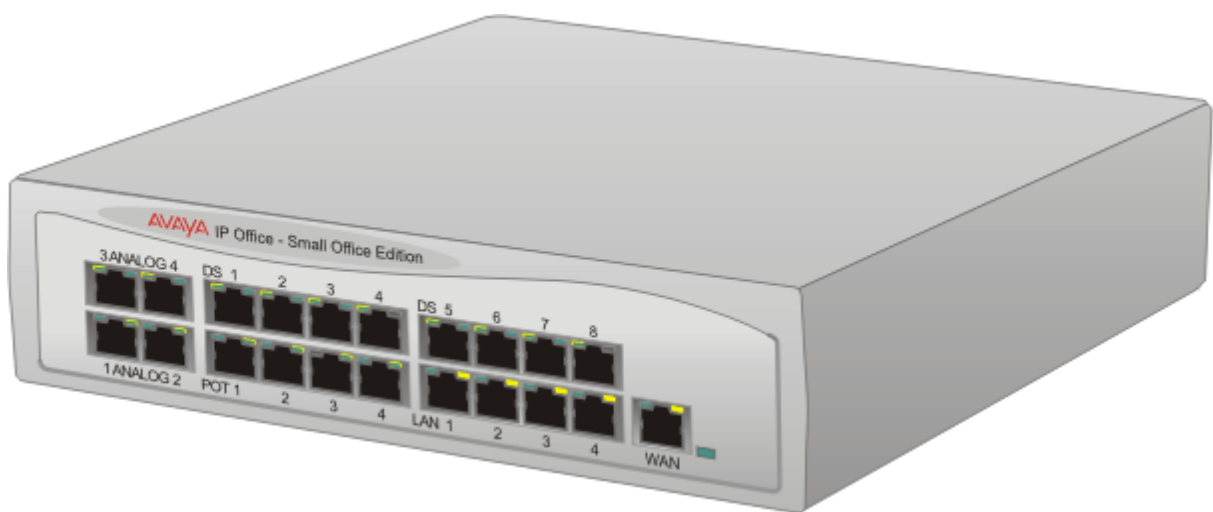

The pre-defined configurations supported in IP Office 3.1 are detailed in the following table.

IP Office - Small Office Edition	Analog Trunks	Analog Extensions	Digital Stations	IP Extensions	VoIP Channels
4T+4A+8DS (3 VoIP)	4	4	8	16	3
4T+4A+8DS (16 VoIP)	4	4	8	16	16

- During power fail, Analog port 2 is connected to POT port 1.

IP Office - Small Office Edition 4T+4A+8DS (3 or 16 VoIP)

The IP Office - Small Office Edition 4T+4A+8DS provides:

- Four Analog Loop Start Trunks (Caller ID enabled).
- Four Analog extension (POT) ports with power fail switchover such that analog trunk port 2 is connected to analog extension port 1.
- Eight Digital Station (DS) ports for selected 2400, 5400 and 6400 phones plus 3810 wireless (US) phones. T3 Series phones are not supported from Release 4.0 onwards on Small Office Edition.
- 3 or 16 VoIP Codecs (G.723.1, G.711 and G.729a) and 48ms echo cancellation.
- 4 Switched Ethernet ports (Layer 2).
- Dedicated Switched Ethernet WAN port (Layer 3).
- 2 x PCMCIA Slots for optional Wireless and Embedded Voicemail card support.
- Expansion Slot for optional WAN card (V35/V24/X.21), BRI or T1 PRI.
- Serial DTE port.
- Audio input port for external music on hold source.
- External O/P socket supporting two relay on/off switch ports, e.g. for door entry systems.

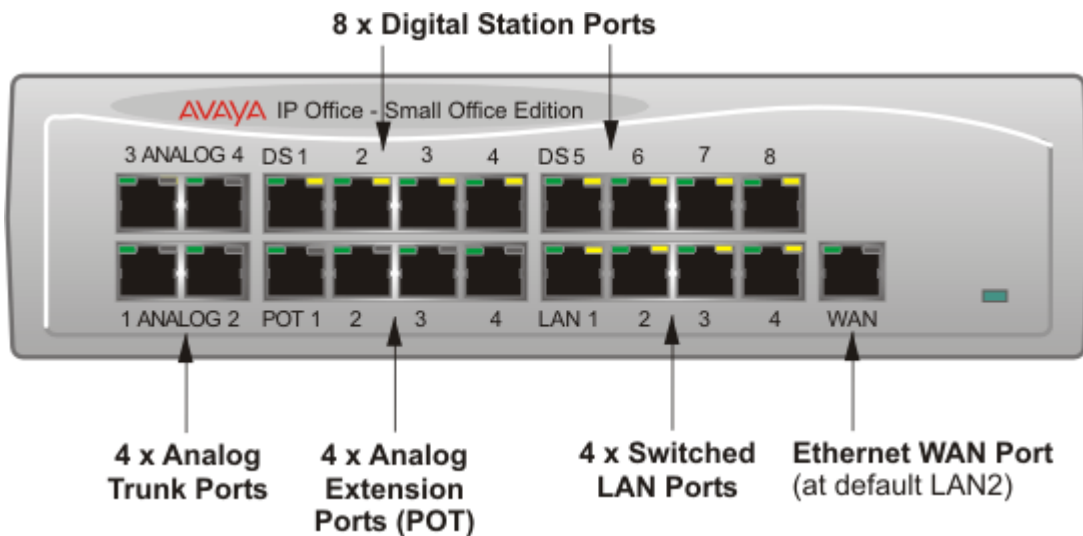

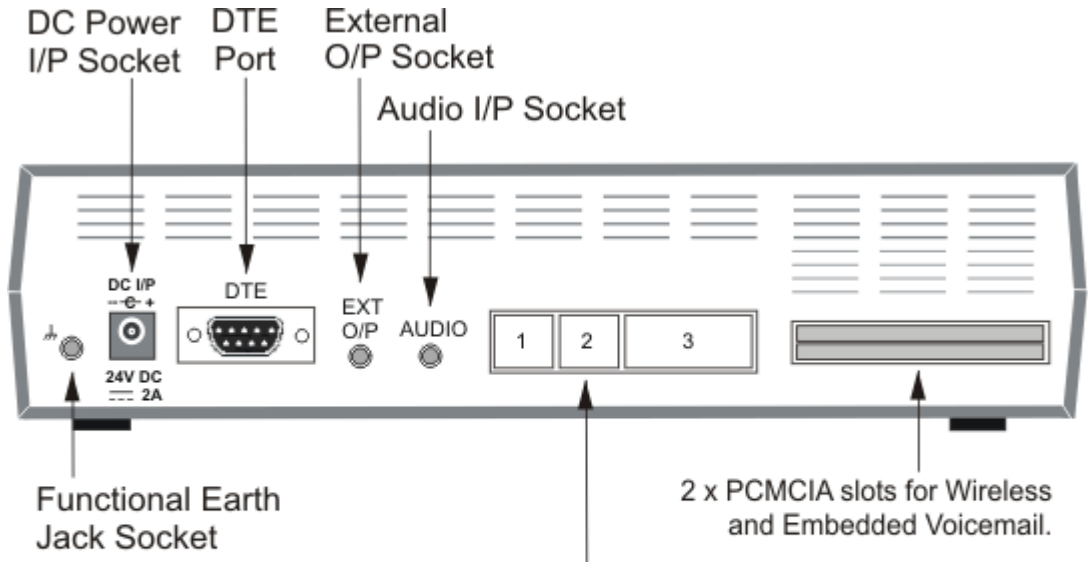

Knock-out panel(s) for trunk module kits, for example:

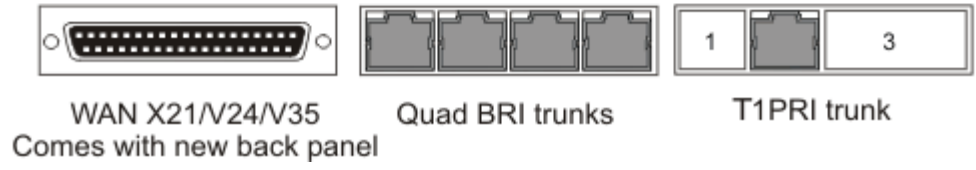

IP Office - Small Office Edition WAN Expansion Interfaces

Both IP Office - Small Office Edition variants provide an expansion slot for an optional WAN interface of the following types (check locally for availability). Each of these interface cards are now described in more detail.

IP400 WAN Expansion

The IP400 WAN Expansion card provides a single WAN connection (X21, V24 or V35 via a 37-way D Type socket). Line speeds up to and including 2Mbps are supported on the interface. The carrier providing the line dictates the actual operating speed, i.e. in some territories the maximum speed may be 1.544M.

IP400 BRI Card

The BRI trunk card provides 4 European Basic Rate ISDN T interfaces (8 trunks).

Details of the supported supplementary services on BRI interfaces are given in the 'Public and Private Voice Networks' section.

- Not available in all territories, check for availability.

IP400 T1 PRI Card

The IP400 T1 PRI card provides a single primary rate trunk interface for supporting voice services and fractional leased lines, providing up to 256K bandwidth on IP and Frame Relay services.

- Not available in all territories, check for availability.

Optional Wireless Access Point

All IP Office - Small Office Edition platforms can be configured to become Wireless LAN access points. An Access Point acts as a Hub in a wireless network providing connectivity between devices in the vicinity. In ideal conditions a range of up to 550M (1750 ft) is achievable although this range will be decreased if walls and other obstacles are present. This is used where local conditions impair coverage and additional Access Points are needed to cover the black spots.

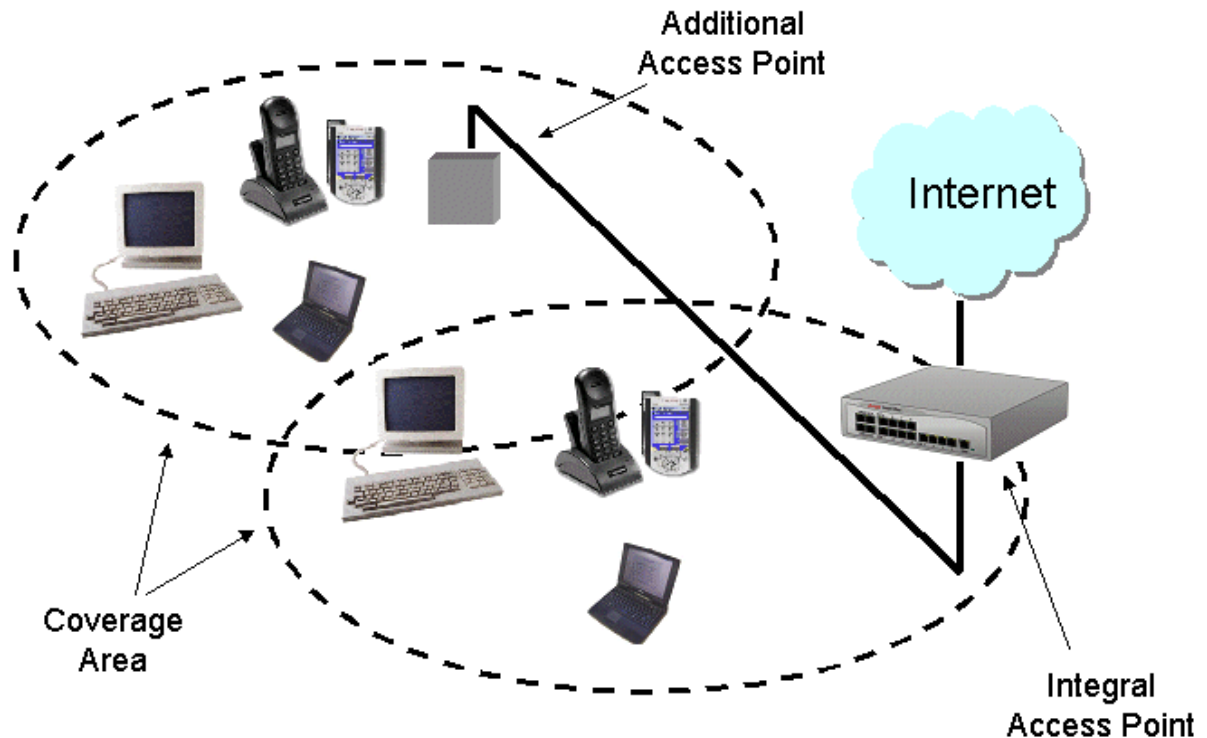

The IP Office - Small Office Edition wireless network can be secured against intruders using either the Wired Equivalent Privacy (WEP) or RC4. WEP uses 64 bit encryption key and RC4 uses a 128 bit encryption key. Only devices with a matching security key can participate in the network.

IP Office - Small Office Edition complies to the IEEE 802.11 and IEEE 802.11b standards meeting the Wireless Ethernet Compatibility Alliance (WECA) Wireless Fidelity Wi-Fi requirements for interoperability.

Summary

- 2.4 GHz to 2.5 GHz band (Scientific Medical and Industrial (SMI) band).
- Automatic fallback 11Mbps, 5.5Mbps, 2Mbps or 1Mbps.
- IEEE 802.11 and IEEE 802.11b Compliance.
- Wireless Fidelity Wi-Fi Compliance.
- Interoperable with other 802.11b compliant devices.
- WEP or RC4 security.
- Range up to 550M (1750ft).

Range (meters/ft)	11Mbps	5.5Mbps	2Mbps	1Mbps
Open	160m/252ft	270m/885ft	400m/1300ft	550m/1750ft
Semi-Open	50m/165ft	70m/230ft	90m/300ft	115m/375ft
Closed	25m/80ft	35m/115ft	40m/130ft	50m/165ft
Receiver Sensitivity dBm	-82	-87	-91	-94
Delay Spread (at FER of <1%)	65ns	225ns	400ns	500ns

For wireless operation, IP Office - Small Office Edition must be fitted with a Wireless LAN card and the Wireless LAN Access Point license key. Alternatively, a 3rd party wireless access point can be connected directly to one of the LAN ports.

Optional Embedded Voicemail with Auto-Attendant

Entry-level voicemail and auto attendant applications are available using the Avaya memory expansion kit in one of the PCMCIA slots on the rear of the Small Office Edition. This provides small locations with an effective embedded messaging solution with auto-attendant without the additional costs of an external PC. The embedded voicemail supports up to 10 hours of message storage. The number of available voicemail ports (to support simultaneous calls to voicemail) is 3 ports on the 3 VoIP model or 10 ports on the 16 VoIP model

Personalized greetings and PIN-code access can be enabled for each mailbox by the mailbox users. Inactivity timeout and return to operator options ensure efficient message handling. Mailbox users can also access their mailboxes when out of office using a simple remote login sequence.

Up to 40 independent auto-attendants can be configured on the platform. These may be linked together to form multiple tiers of attendants. The choice of which auto-attendant is to answer a call can be made on any of the criteria on the Incoming Call Routing form such as called number, calling number and time of day.

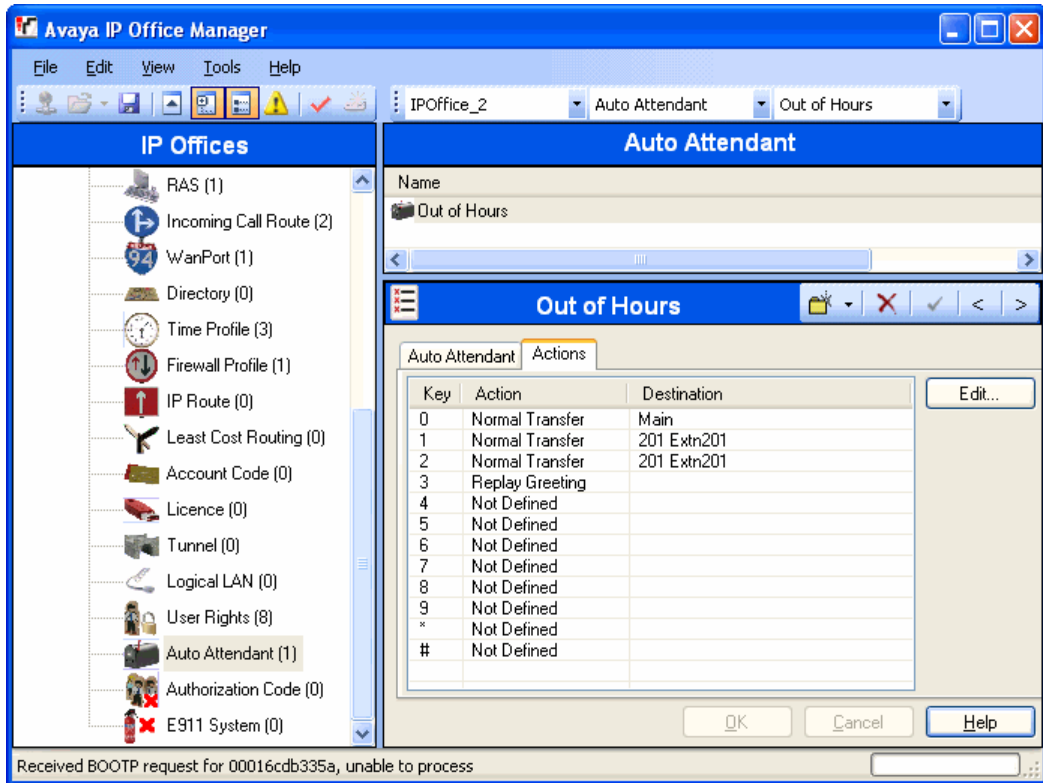

Each auto-attendant has a single menu of 12 items (0..9, *, #) that a caller can select from to either be transferred to a predefined number, to another auto attendant or to replay the greeting. The greeting for the menu is controlled by time profiles to allow three alternative messages to be played i.e. Morning, Afternoon and Evening. These messages can be labeled and then re-used in as many auto-attendants as required.

Please note that the IP406 V2 and IP500 embedded voicemail memory cards are identical but these are not interchangeable with the Small Office Edition card. Only Avaya supplied memory cards with the voicemail and auto attendant applications pre-installed can be used.

IP400 Trunk Interface Cards

IP400 trunk interface cards fit into the card slots on the Small Office Edition, IP406 V2 and IP412 control units and in any slot of the IP500 when combined with the IP500 Legacy Card Carrier. They provide analog, ISDN or CAS trunk connectivity. Not all interfaces are available in all territories. The following table shows how many of each card type are supported by each of control unit.

	Small Office Edition	IP406 V2	IP412	IP500*
IP400 Universal Analog Trunk 4	✗	2	2	2
IP400 Quad BRI	1	2	2	2
IP400 PRI E1	✗	2	2	2
IP400 Dual PRI E1	✗	1 (Slot A)	2	2
IP400 E1R2	✗	2	2	2
IP400 Dual E1R2	✗	1 (Slot A)	2	2
IP400 PRI T1	1	2	2	2
IP400 Dual PRI T1	✗	1 (Slot A)	2	2

* Each card requires the use of an IP500 Legacy Card Carrier. IP500 does not support E1R2 coax cards.

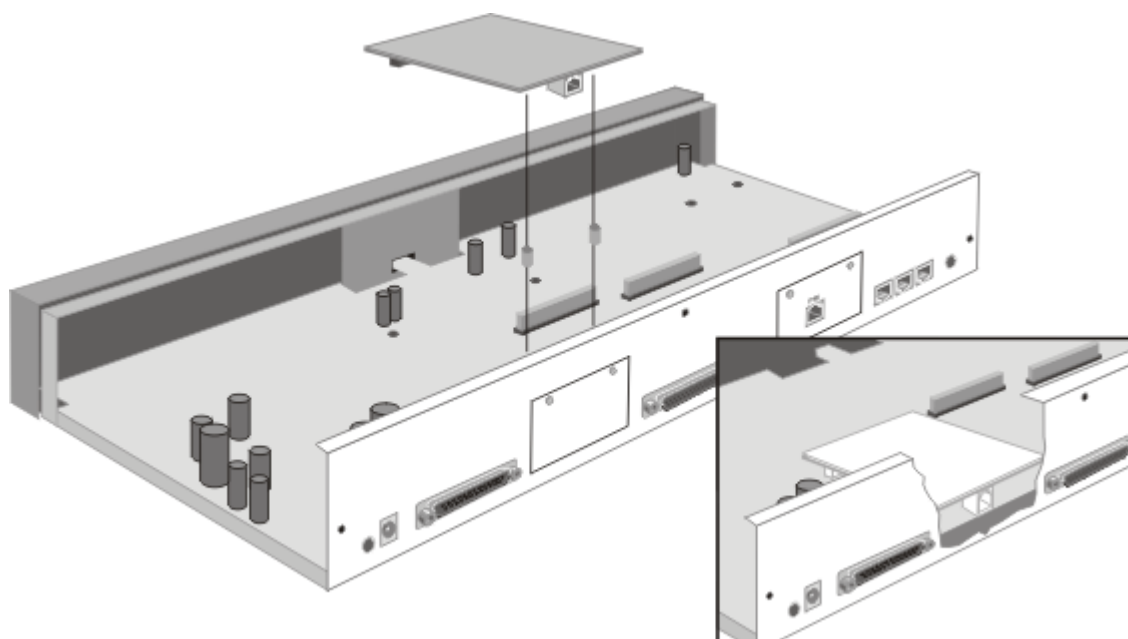

IP400 BRI Card

The BRI trunk card provides 4 Basic Rate ISDN T interfaces (8 trunks). Details of the supported ISDN supplementary services on BRI interfaces are given in the 'Public and Private Voice Networks' section.

IP400 PRI Cards (T1/E1/E1R2)

Available in single and dual versions the IP400 PRI card provides single and dual primary rate trunk interfaces respectively. The PRI is available in T1, E1 and E1R2 MFC variants depending on the territory. The dual version is only supported on the IP412, in slot A of the IP406 V2 and in the IP500 using an IP500 Legacy Card Carrier. The Small Office Edition only supports the single T1 PRI card (not E1 or E1R2).

Details of the supported ISDN supplementary services and protocols for each PRI are given in the 'Public and Private Voice Networks' section.

T1 trunk cards incorporate an integrated CSU/DSU. The CSU function allows the trunk to be put in loop-back mode for testing purposes. This can be set manually, using the monitor application, or automatically from a Central Office sending a Line Loop Back (LLB) pattern. The DSU function allows the T1 trunk to be shared between data and voice services.

IP400 Universal Quad Analog Trunk (LS) Card

This card provides four analog trunk ports. These are 2-wire loop start interfaces and are available in all territories. This card supports Caller ID where provided. With IP Office R3.1 and later, this module supports optional 16ms echo cancellation.

Please note that ground start analog trunks are supported via the IP Office Analog Trunk 16 Expansion Module.

IP500 BRI So8 Module

The IP500 BRI So8 module provides 8 S-Bus interfaces for Basic Rate ISDN devices, such as video conferencing, fax servers or ISDN telephones.

For installations in a rack, this module requires the IP500 Rack Mounting Kit. The IP500 BRI So8 Module is functionally identical to the IP400 So8 Module.

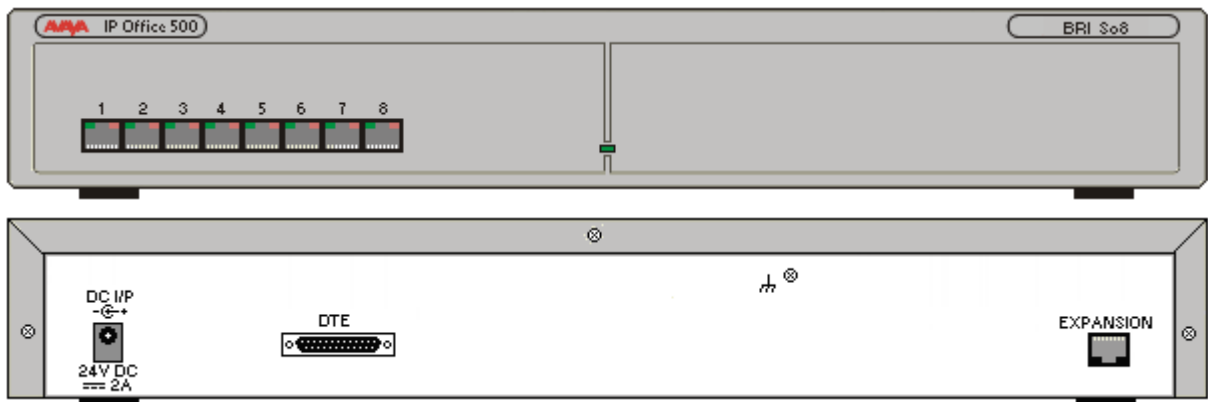

The IP500 BRI So8 expansion module supports both point-to-point and point-to-multipoint connections. A maximum of 10 terminal endpoints identifiers (TEIs) are supported on each bus.

IP400 Phone Module

This module provides additional analog telephone interfaces:

- Two Wire
- DTMF signaling (No rotary or Loop Disconnect)
- Time Break Recall (No Earth Recall)
- Caller ID capable
- Message Waiting Indication (MWI) capable - High Voltage, Pulsed High Voltage, Line Reversal

The IP400 Phone module is available in 3 versions, giving 8, 16 or 30 extensions. Telephones can be located up to 1km from the control unit. For extensions located "out-of-the-building" additional line protection will be needed. For more information on cabling and out of building guidelines, see the IP Office Installation Manual.

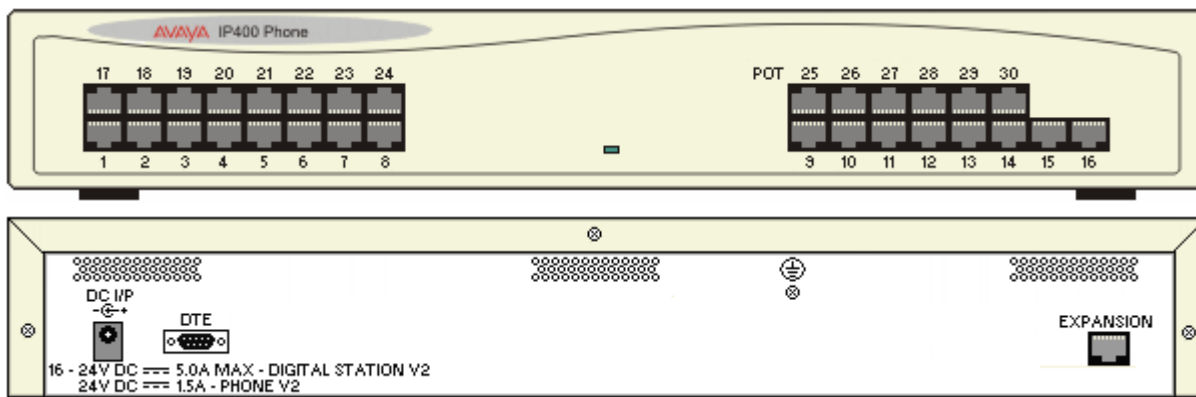

- IP Office Phone Modules provide support for a variety of analog MWI methods. These methods are 51V Stepped, 81V, 101V and Line Reversal. The 101V method is only supported when using a Phone V2 expansion module.
- Each analog port can support a device of maximum 1 REN.
- On analog ports, call information is sent while the phone is ringing, and cannot be updated during a call or set on an outbound call (the phone may do a local match but this is not controlled by the IP Office). The primary purpose of displays is to give information about incoming calls. Where the Caller Display standard chosen supports the delivery of text (extension name) as well as the number, both are delivered.
- An analog extension port can be set for external Paging operation. It does not operate like a normal extension and is connected to external equipment through an isolation device. The Port will always be busy so it cannot be called directly and can only be accessed by using a shortcode. When not receiving a Page the port will remain silent, when being paged the page tone is sent before the speech path is opened.

IP400 Digital Station V2 Module

This expansion module provides additional Digital Station (DS) ports for selected Avaya 2400, 4400, 5400, 6400, T3 (EMEA only) series phones and 3810 wireless phones (NA only). The IP400 Digital Station module is available in 2 variants; 16 or 30 extensions.

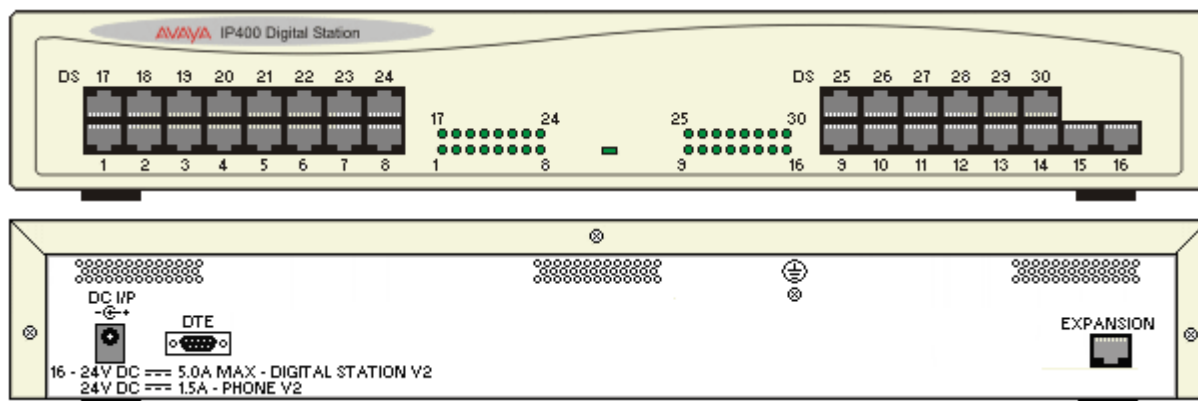

- Telephones can be located up to 1km from the control unit. For extensions located "out-of-the-building" additional line protection will be needed. For more information on cabling and out of building guidelines, see the IP Office Installation Manual.
- For systems where Direct Station Select (DSS) Units are being used, IP Office supports a maximum of:
 - Eight EU24 and or EU24BL per system.
 - Two XM24 units on each Digital Station expansion module to a maximum of 10 x XM24 units per system.
 - Two 4450 units on each Digital Station expansion module to a maximum of 8 x 4450 units per system.
 - T3 DSS units.

See the Telephones Section for specific limits on the number of each type of telephone supported on DS modules.

IP400 Analog Trunk 16 Module

This expansion module provides an additional sixteen Loop Start or Ground Start two-wire analog trunks. (Ground start trunks are not available in all territories) The first two trunks on the module which are automatically switched to power fail sockets on the rear of the unit in the event of power being interrupted must be loop start for correct power fail operation.

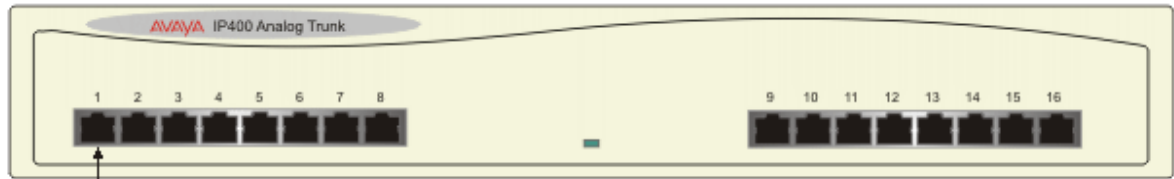

Analog Trunk Ports
Individually switchable to loop or ground start.



DC Power Input Socket
To external power supply unit.

DTE Serial Port
25-pin D-type socket.

Functional Grounding Point

Power Fail Analog Phone Sockets
During power fail:
PF1 = Analog Trunk 1.
PF2 = Analog Trunk 2.

To IP Office Control Unit.

Internal Daughter Cards

Internal Daughter Cards are fitted inside the IP406 V2 and IP412 control units.

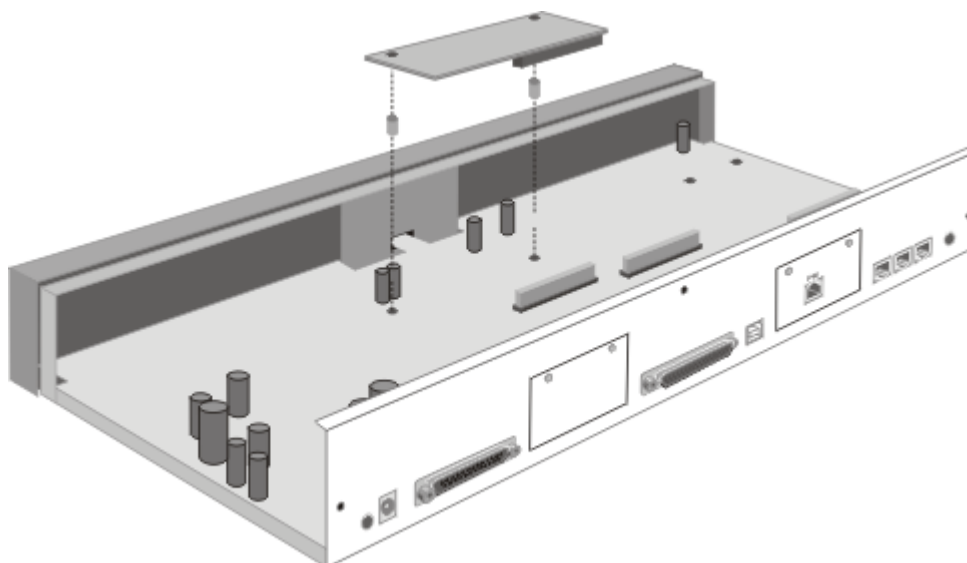

IP400 Voice Compression Module – 4/8/16/24/30 ports

The Voice Compression Module (VCM) is used for Voice over IP (VoIP) applications in the IP406 and IP412 control units. Five VCM variants are available supporting 4, 8, 16, 24 and 30 channels of compression. The echo cancellation capabilities of the VCM cards vary. The VCM 4, 8, 16 and 24 cards offer 64ms of echo cancellation while the VCM 30 card offers 25ms.

The IP406 V2 supports a single VCM while the IP412 can have any two VCMs installed.

The following table shows how many of each card are supported by each platform.

	IP406 V2	IP412	IP500
IP400 VCM 4	1	2	2*
IP400 VCM 8	1	2	2*
IP400 VCM 16	1	2	2*
IP400 VCM 24	1	2	2*
IP400 VCM 30	1	2	2*
IP400 VCM 5/10/20 <i>(no longer sold)</i>	1	2	✗
IP500 VCM 32	✗	✗	2
IP500 VCM 64	✗	✗	2

*Each card requires the use of an IP500 Legacy Card Carrier.

IP400 Internal Modem Card

An internal modem card with 12 modems can be installed in both the IP406 V2 and IP412 to provide dial-up capacity that is better matched to remote access requirements of customers. The Internal Modem card allows up to 12 simultaneous V.90 (56kbps) analog modem calls into the IP Office.

Index

- A -

- Absence Text 131
 - setting 131
 - strings 131
- Absent Text Message 183
- Acceptable Delay 168
- Access Point 99
- accessing
 - Database Information within Call Flows 248
 - Email 244
 - Office LAN 332
- Account 16, 141, 168, 174, 198, 229, 232, 243, 255, 263, 308
- Account Code Recording 255
- Account Codes 141, 255, 308
- ACD 154
- ACM 18, 185, 258
- ACM RFA 258
- Acquire Call 132
 - executing 154
 - waiting 154
- ACSII-CSV 291
- Active Directory 243
- ActiveX Data Objects 248
- Additional ISDN 174
- addressing
 - Domain Name Service 194
 - voicemails 259
- admin 246
- Administration 7, 58, 146, 172, 226, 243
- Administrator 16, 132, 150, 246, 248, 250, 253, 256, 291, 296
 - Change 226
- ADMM 97
- ADO 248
- Advanced Small Community 152, 183
- Advanced Small Community Networking 152, 183
- Advice Of Charge 174, 217
- Alarm Calls 259
- Alert 77, 80, 82, 97, 112, 133, 138, 140, 151, 160, 220, 240, 290
 - User 154
- ALG 178
- Algorithmic Delay 168
- All Calls 139
- All-in-one 7, 17
- allocated 194, 197, 232, 277
 - User Rights 142
- Alpha 86
- Alphabetic Keystrokes 225
- Alphanumeric 85, 101, 117, 259
- Alphanumeric Data Collection 259
- Alternate Call Routing 14
- Alternate Route Selection 133, 142, 188
- Analog 16 17, 310
- Analog 16 Module 310
- Analog Extensions 47, 120, 133, 154, 346
- analog lines 276, 301
- Analog Phone 17, 18, 52, 141, 155, 158, 310, 313
- Analog Phone Ports 313
- Analog Telephone Features 116
- Analog Telephones 116, 124, 155, 160, 346
- Analog Telephones/POTS 115
- Analog Trunk 16 298
- Analog Trunk 16 EU 298
- Analog Trunk 16 NZ 298
- Analog Trunk 16-port 174
- Analog Trunk Module 45, 332
- Analog Trunk Module 16 45, 332
- Analog Trunk Ports 313
- Analog Trunk Restriction 276
- Analog Trunks 45, 52, 142, 174, 188, 193, 276, 298, 301, 313, 332, 343
- Analog/digital 167
- ANI 174, 217, 256
- ANLG 47
- Announcements 7, 152, 153, 232, 233, 234, 259
- ANSI T1.401
 - conform 174
- ANSI T1.607 313
- Answer Interval 144
- Answered Calls 220
- Anti-Tromboning 183
- AOC 156, 174
- APAC 90, 97, 117, 124
- Appearance 120, 136, 138, 139, 225
- Appearance Buttons 138, 139
- appearance/feature 58, 84
- Applicable 52, 136, 147, 251, 255
- Application Level Gateway 178
- Applications Platform 16, 18
- Applications Platform Features 16
- ARP
 - receiving 197
- ARS 133, 142, 188
- Assisted Transfer 234, 259
- Audio 45, 85, 86, 87, 99, 133, 160, 161, 168, 170, 234, 256, 274, 275, 298, 313, 332
- Audio Codec 168
- Audio CODECs 170
- Audio Conferencing 274
- Audio Volume 85, 86, 87
- Audio waveform 256
- Audiotex 234
- Audit 169, 291
- AUDIX RFA 185
- August 185, 343
- August 2003 185

- Australia 300
- Austria 300
- Authorization Codes 141
- Auto Connect 197
- Auto Connect Time Profile 197
- auto-attendant offers 246
- Auto-Attendant/Audiotex 259
- Auto-Create Extensions 161
- Automatic Call Distribution 154
- Automatic Callback 128
- Automatic Intercom 136
- Automatic IP 15
- Automatic Number Identification 174
- automatic/manual
 - allow 255
 - automatic/manual recording calls 255
- B -
- Back When Free 156
- Backlight 82, 84, 103
- backlit 99, 120
- BACP 196, 314
- Band DTMF 161, 170
- Bandwidth Allocation Control Protocol 196, 314
- Bandwidth Required For Each 168
- Bandwidth Required For Each Voice Call 168
- bar 142, 307
 - queue panel displays 220
- Base 7, 18, 45, 47, 52, 58, 97, 112, 120, 194, 298, 310, 314
- Base Unit 112, 120, 194, 298, 310
- Base Unit Power Supply Adapter 112
- BaseT Ethernet 77, 80, 82, 85, 86, 87
- Basic Commands 259
- Basic Rate 174, 194, 343, 345
- Basic Rate ISDN 343, 345
- B-channel 64kbps 313
- Bellcore Special Report SR4287 313
- Belt Clip 99, 110, 111, 112
- bi-directional 158
- BLF 183, 225, 226, 254
 - form 146
 - groups 220
- BLF Groups 225
- BLF Panel 220, 226
- Blind Transfer 129
- BlindTransfer 306
- Book Shop 249
- BOOTP 314
- Bootstrap Protocol 314
- Bothway 197
- bps 168
- branch maximizes 172
- branches 7, 158, 172
 - DEFINITY/ACM 185
 - Branch-to-Branch 15
- Brazilian 234, 249
- Break Out 156, 254
 - set 134
- Break Out Dialing 134
- Breakout 183, 233
 - Reception 259
- Breakout Dialing 183
- BRI 45, 52, 54, 138, 172, 174, 313, 332, 343
- BRI ISDN 172
- BRI S-interfaces
 - ISDN 54
- BRI So8 45
- BRI-4 45
- BRI-8 45, 47
- Bridged Appearance 136, 138, 139
- bridged appearance button matches 139
- Bridged Appearance Buttons 138, 139
- Built-in IP 181
- Business moving 301
- business needs 141
- business requiring 190 301
- business-to-business 192
- Busy
 - DND 220
- Busy Lamp Field 146, 183, 217, 220
- Busy Lamp Field Panel 220
- Busy On Held 156
- Busy Subscriber
 - Call Completion 174
- Busy/Engaged 251
- buy/lease 7
- bypass
 - DND 133
- Bytes 168
- C -
- C3000 243
- Cable 44, 47, 52, 55, 124, 165, 310, 346, 347
- Cable Lengths 310
- CALA 124, 298
- Call 85, 144, 152, 189, 192, 198, 228, 256, 290
 - Advice of charge during 174
- Call Appearance 136, 138, 139
- Call Appearance button 136, 138, 139
- Call Appearance/Feature 58, 84
- call arrives 220
- Call Back Sender 259
- Call Back When Free 128, 129, 183
- Call Barring 141, 142
- call billing 229
- Call Center 16, 114, 154, 228, 243, 252
- Call Completion
 - Busy Subscriber 174
- call costing 141
- Call Coverage 132, 138, 140

- Call Coverage Buttons 138, 140
- Call Detail Records 290
- Call Details 290, 296
- Call Details Panel 220
- Call Duration 220
- call flow programming interface 250
- Call Flow Utilizing Database Actions 248
- Call Flows 247, 248, 249, 250, 275
- Call Forwarding 14, 20, 126, 144, 247
- Call Handling 7, 16, 20, 126, 131, 217, 220
- Call History 147, 217, 220, 226
- Call Hold 182, 185
- Call Identifier 308
- Call Intrude 133, 156
- Call List 156
- Call Listen 156, 234
- Call Log 58, 80, 82, 85, 86, 87, 127, 134, 141, 217
- Call Pickup 135, 156
- Call Pick-up 111, 183
- Call Pickup Any 156
- Call Pickup Extension 154
- Call Pickup Extn 156
- Call Pickup Group 156
- Call Pickup Line 156
- Call Pickup Members 156
- Call Pickup User 156
- Called/Calling Line ID Presentation 173
- Called/Calling Name 173, 182
- Called/Calling Name Presentation 173
- Called/Calling Number 182
- Caller Display 115, 346
- Campaign Manager 16, 234, 254, 259
- Can Intrude 133, 307
- Cancel All Forwarding 156
- Cancel Ring Back When Free 156
- Captaris 243
- carrying
 - Fax 169
- CAS 332, 343
- Cascaded Out-calling 253
- Castelle 243
- Castelle Fax 243
- Castilian 234
- CAT 165
- CAT5 165, 310
- Catalyst 165
- CCBS 174
- CCC 45, 134, 152, 183, 234
- CCP 314
- CD 256
- CD-Rom 229
- CDRs 141
- CE/UL/Dentori Safety Approved 310
- cell/mobile 246
- Central Office 52, 174, 192, 193, 332, 343
- Centralized 18, 20, 126, 172, 181, 183, 185, 232, 234, 258, 259
- Centralized INTUITY Audix 232
- Centralized Messaging 258
- Centralized VM 258
- Centralized Voice Mail 183
- Centralized voicemail 18, 172, 185, 234, 259
- Centralized Voicemail Services 259
- Challenge Handshake Authentication Protocol 196, 314
- Channel Associated Signaling 174
- Channel Monitor 156
- Channel Voice Compression 298
- CHAP 193, 196, 198, 199, 314
- Charger Unit 112
- checkbox 244
- Checking 174
- Circuit Switched 173
- Circuit Switched Data Call/Basic 185
- Circuit Switched Data Call/Basic Call 173, 185
- Circuit Switched Voice Networking 173
- Circuit-switched 158
- Cisco 114, 165
- Cisco Systems 165
- C-LAN
 - DEFINITY 9.5 185
- Clear Call 156
- Clear CW 156
- Clear Hunt Group Night Service 156
- Clear Hunt Group Out
 - Service 156
- Clear Hunt Group Out Of Service 156
- Clear Quota 156
- CLI 117, 217, 306, 313
- CLI Feature 117
- CLI Schemes 313
- CLI/ANI 234
- CLIP 174
- CLIR 174
- Clock 194
 - Speaking 234, 259
- closet/switch
 - wiring 165
- Co-Ax 298
- Code Used 141
- Codec G.711 97
- Codecs 77, 80, 82, 85, 86, 87, 167, 185
- Cold Start 291
- Color Backlight Display 82
- COLP
 - Inhibits 174
- COLR 174
- Comfort 58, 99, 123
- comma-separated 229
- Common Features 77, 80, 82, 84, 85, 86, 87

- Compact Business Center 16, 18
- Compact Contact Center 16, 234
- Compact Flash 298
- Compact Mode 217
- companies' LANs 158
- company's
 - IP Telephony unites 158
- compared 97
 - Service Provider conferencing 274
- Compressing
 - IP/UDP/RTP Headers 314
- Compression Control Protocol 314
- Computer Telephony Integration 44, 228, 229
- Concise MIB Definitions 314
- Concurrent Calls
 - Maximum Number 259
- Conference Add 156
- Conference Bridge 7, 153, 275, 276, 277
- Conference Calling 14, 155
- Conference Control Display 217
- Conference entry/exit 277
- Conference Held Calls 220
- Conference Meet Me 156
- Conference Resources 276
- Conference Room 124, 220, 225
- conferencing 14, 44, 45, 77, 80, 82, 112, 127, 146, 220, 225, 274, 275, 276, 296, 345
 - benefits relating 277
 - Eliminating 7
 - manage 277
 - relating 277
- Conferencing Center 18, 45, 155, 217, 220, 276
- conferencing service 7
- Conferencing tone 127
- Conferencing tone depending 127
- congestion-control 170
- Connected Line Identification Restriction 174
- connection-oriented 181
- Contact Center 16, 44, 58, 123, 154, 248, 254, 332
- Contact Center Features 154
- Contact Management 16
- Contact-ability 247
- contactable 90
- ContactStore 18, 45, 234, 255, 256, 263
- ContactStore Search 234
- Continuous Loop Greeting 259
- Control Unit Conference Capabilities 276
- controlled according 256
- controlling calls 142
- copier/scanner 243
- CoS 169
- Country Availability 300
- CPE 195
- CPU 256
- CPU loading 256
- CRC 174
- Create' 252
- CreateCall 306
- CRM 243, 332
- CS-ACELP 170
- CSU 52, 174, 295, 343
- CSU Loop-Back 295
- CSU/DSU 52, 174, 343
- CTI 16, 45, 132, 228, 229, 230, 277
- CTI interoperability
 - levels 228
- CTI Link Lite 228
- CTI Link Pro 45, 228, 229
- CTI Link Pro RFA 229
- CTI middleware 228
- CTR3
 - ETSI T-Bus Interface 313
- CTR4
 - ETSI T-Bus Interface 313
- cust 131
- Customer Contact 280
- Customer Contact Center 280
- Customized Voicemail 259
- CW 156
- CW1308 310
- Cyclic Redundancy 174
- Czech Republic 300
- D -
- D Message 308
- Data Access Components 248
- Data Call 151, 153, 173, 196
- Data Channels 167, 332
- Data Communication Solution 15
- Data Communication Solution Features 15
- Data Compression 196
- Data Header Compression 196
- Data Jack 116
- Data Rates 313
- data traffic 99, 168, 181, 195
- Database 127, 234, 243, 248, 249, 254, 255, 256
- Datagram Protocol 314
- Day One
 - starting 7
- Day/Night service 120
- D-channel 16kbps 313
- D-channel 64kbps 313
- DDI 129, 174, 306
- DDI/DID 20, 97, 126, 151, 174, 246
- DDI/DID call 151
- DECT 90, 97, 174
- DECT Networking 97
- Default
 - E&M 313
- default greeting 130

- default numbering 133
- Definable PIN Code 259
- DEFINITY 58, 185
- DEFINITY 6400 58
- DEFINITY 9.5
 - C-LAN 185
- DEFINITY G3si 185
- DEFINITY/ACM
 - branches 185
- DEFINITY/ACM occupying 185
- Delete Message 259
- deleting 130
- Delphi 306
- Denmark 300
- Deploying
 - IP 165
- Depth 110, 310
- Designing
 - IP Telephony 160
- Desk/Wall Mount 116
- desklers 134
- desking 134
- DevConnect 230
- Developer Connection Program 230
- DeveloperConnect 230
- Developers 228, 229, 230, 307, 308
- DevLink 229, 308
- DevLink Lite 229
- DevLink Pro 229
- DevLink Reserved Fields 308
- DHCP 15, 101, 103, 169, 194, 198, 277, 314
- DHCP Server 194, 198, 277
- Dial 3K1 156
- Dial 56K 156
- Dial 64K 156
- Dial calls 136, 141
- Dial CW 156
- Dial Direct 156
- Dial Direct Hot Line 156
- Dial Emergency 141, 156
- Dial Extn 156
- Dial Inclusion 156
- Dial On Pickup 155
- Dial Pad 220, 225
- Dial Paging 156
- Dial Plan 133
- Dial Speech 156
- Dial V110 156
- Dial V120 156
- Dial Video 156
- Dialed Number 127, 129, 142, 174, 256
 - controlling 146
- Dialed Number Identification String 174
- dial-in/dial-out to/from 193
- Dialing In 167, 174, 193, 198, 332
- dialing plan 133, 172
- DialPhysicalExtensionByNumber 156
- DialPhysicalNumberByID 156
- Dial-Up Circuit Support 194
- DID 129, 174
- DID/DDI 174
- Differentiated Services Field 314
- Diffserve 181
- Digital Station 16 Module V2 298
- Digital Station 30 298
- Digital Station 30 Module V2 298
- Digital Station Expansion Module 55, 347
- Digital Telephones 18, 112
- Digital Wireless 3810 Telephone 112
- Digital Wireless North American 90
- Dimensions 110, 310
- Direct Dialing 20, 126, 136, 246
- Direct Dialing In 174
- Direct Inward Dialing 129
- Direct Media 85, 161, 167, 234
- Direct Media Path 161
- Direct Sequence Spread Spectrum 101
- Direct Station Select 55, 146, 347
- Directory 7, 15, 117, 127, 147, 172, 198, 220, 225, 307
- Directory Entry 220
- Directory Panel 220
- Directory.csv 291
- Disable ARS Form 156
- Disable Internal Forward Busy 156
- Disable Internal Forward Unconditional 156
- Disable Internal Forwards 156
- discover
 - NAT 178
- Disk Space 256, 263
- Display Backlight 82
- Display Msg 156
- Distinctive 129, 217
- Distinctive Ringing 129, 217
- distinguish
 - doorphone 120
- distribute 152, 183, 229, 243
 - voicemail 252
- Distributed Hunt Groups 152, 183
- Disturb 131, 230
- DMS100 174
- DMS-100 313
- DMS-250 313
- DMZ 178
- DND 133, 144
 - bypass 133
- DNIS 174, 256
- DNS 194, 196
- Do Not Disturb 131, 133, 136, 144, 146, 156, 230, 307

- Do Not Disturb Exception Add 156
- Do Not Disturb Exception Delete 156
- Do Not Disturb Off 156
- Do Not Disturb On 156
- Domain 194, 196, 263
- Domain Name Service 194, 196
- Door Entry 45, 120, 135, 155, 225, 332
- doorphone
 - distinguish 120
- doorphone calls 120
- Doorphone Entry 120
- Doorphones 120
- DS 17, 47, 55, 58, 77, 80, 82, 85, 86, 87, 112, 310, 314, 347
- DS 16 Module 310
- DS 30 Module 310
- DS Field 314
- DS Phones 77, 80, 82
- DSS 55, 85, 86, 87, 88, 124, 146, 254, 347
- DSS key 254
- DSS key incorporates 254
- DSS Modules 85, 86, 87, 88
- DSS Unit 124
- DSS/BLF 128
- DSS/BLF key 128
- DSSS 101
- DSU 52, 174, 343
- DTE 313
- DTE Port 313
- DTMF 116, 120, 142, 161, 170, 174, 188, 230, 246, 248, 254, 314, 346
 - sending 217
- DTMF Dialing 116
- DTMF Digits
 - RTP Payload 314
- DTMF signaling 346
- DTMFA 313
- DTMFC 313
- DTMFD 313
- D-Type 313
- D-type on IP412 313
- Dual Charger 99
- Dual PRI E1 47
- Dual PRI E1R2 RJ45 47
- Dual PRI T1 47
- Dual Universal PRI 45
- Dutch 110, 111, 234, 249
- DVD 256, 263
- Dynamic 15, 77, 80, 82, 85, 86, 87, 181, 314
- Dynamic Host Control Protocol 314
- Dynamic IP 77, 80, 82, 85, 86, 87
- E -
- E&M DID 174
- E&M Switched 56K 174
- E&M Tie Line 174
- E.164 314
- e.g 142, 188
- E1 17, 52, 138, 173, 174, 185, 258, 276, 332, 343
 - including 14
- E1 ISDN 276
- E1 PRI 138
- E1/PRI 298
- E1/T1 185, 194
- E1R2 52, 138, 174, 298, 332, 343
- E1R2 Channel Associated Signaling 174
- E1R2 MFC 52, 343
- E1R2 Primary 298
- E911 155
- Earth Loop Recall 346
- Echo 167, 298, 343, 349
 - 128ms 14
- e-commerce
 - Internet 192
- ECT 174
- eg 131
- Eliminating
 - conferencing 7
- ELR/TBR switchable 117
- Email 7, 44, 99, 130, 192, 193, 197, 232, 234, 263, 295
 - accessing 244
 - Copy 259
 - Forward 259
 - leading 243
 - reading 16
 - sends 256
 - subject 240
 - Voicemail 240
- Email addresses 244, 256
- Email application 240
- email inboxes 16
- Email Notification 240, 295
- Email Reading 244
- email reading checkbox 244
- Email Systems 16, 240
- emails 234, 240, 244
- e-mails 181
- Embedded 17
- Embedded Applications 77, 80, 82, 85, 86, 87
- Embedded Messaging 17, 130
- Embedded Messaging Card 295
- Embedded Voice Memory 313
- Embedded Voicemail 16, 17, 45, 153, 156, 167, 232, 233, 259, 295, 298
- Enable ARS Form 156
- Enable Internal Forward Busy 156
- Enable Internal Forward Unconditional 156
- Enable Internal Forwards 156
- enabled/disabled 133
- Encapsulation 195

- Encapsulation 195
 - Frame Relay 170
- encoding
 - G711 101, 103
- Enlarged earpiece 104
- Enterprise 99, 114, 243, 274
- ENTITY MIB 314
- entry/double 277
- Entry-level voicemail 233
- EnumerateAddresses 306
- equating
 - Exchange User 263
- Equisys 243
- ERP 243
- escalates
 - doctor's mobile/cell 253
- ESP 314
- ESP DES-CBC Cipher Algorithm 314
- Estimated Time
 - Answer 259
- Estonia 300
- ETA 259
- Ethernet 15, 17, 45, 54, 77, 80, 82, 84, 85, 86, 87, 97, 99, 158, 165, 178, 192, 194, 298, 332
- Ethernet eliminates 165
- Ethernet LAN 99, 158
- Ethernet Ports 17, 77, 80, 82, 85, 86, 87, 178, 192
- Ethernet Switch 15, 192, 194, 298
- EU24 55, 82, 84, 347
- Euro ISDN 52
- Euro-ISDN BRI 298
- Except 85, 88, 145, 178, 181, 276, 295, 298
 - 4601 165
- Exchange/SMTP
 - GFI FAXmaker 243
- executing
 - Acquire Call 154
- Executive Wireless 124
- Exit Queue 259
- Expansion 17, 44, 45, 47, 54, 55, 77, 80, 82, 84, 88, 174, 295, 296, 298, 301, 310, 332, 346, 347, 348
- Expansion Cards 298
- Expansion Module Digital Station 30 298
- Expansion Module Phone 30 298
- expansion module provides 54, 348
- Expansion Modules 17, 45, 54, 55, 82, 88, 295, 298, 310, 332, 346, 347, 348
- Expansion Units 310
- Explicit Call Transfer 174
- Explicit IV 314
- Exporting 291
- Extended Callback Control Protocol 196
- Extended CBCP 196
- Extended Personal 234, 251, 259
- Extended Personal Greetings 234, 251
- EXTENSION NUMBER 291
 - extension/VCM 298
 - External 54
 - External Bell 313
 - External Call 129, 133
 - External Control 155
 - External Control Port 155
 - External Expansion Modules 54, 298
 - External Number 144, 153, 174, 233
 - External O/P 45, 332
 - External Participants 276
 - External Systems
 - Forward Emails 259
 - Extn Login 156
 - Extn Logout 156
 - Extreme Alpine Series 161
 - Extreme Alpine Series switches 161
 - Extreme Networks 161
- F -
 - failover 54
 - Fall Back 151, 192
 - Fast Forward 130, 233, 259
 - Fast Forward Message 259
 - Fast Start 161
 - Fax 18, 161, 170, 185, 233, 243, 244, 259, 345
 - carrying 169
 - routing 234
 - fax calls 161, 169
 - Fax Messages 243, 244
 - Fax Relay 170
 - Fax Transport 161
 - Faxination 243
 - FaxMail Pro 243
 - FCC 101, 103, 313
 - Feature Key 18, 45, 77, 97, 298, 332
 - Feature Licensing 18
 - FEATURE NAME 291
 - Feature Support 259
 - Feature Table 116
 - Fenestrae 243
 - Fenestrae Faxination Server
 - Microsoft Exchange 243
 - Field Data 308
 - File Transfer Protocol
 - including 197
 - Finland 300
 - Finnish 110, 111, 234
 - firewall 15, 44, 181, 192, 193, 197, 277
 - Small Office Edition offers 194
 - firewall/VPN 7
 - firewalled 192
 - firewalled Layer 192
 - firewalls 197, 198
 - Firstly
 - TTS 244

- Fixed Feature Buttons 77, 80, 82, 85, 86, 87
- Flash Hook 156
- Flash Memory 233
- Flow Control 77, 80, 82, 85, 86, 87, 170
- Follow Me 136, 144, 145, 156, 234, 247, 307
- Follow Me Here 156
- Force login 307
- Forced Account Code
 - set 141
- Forward All 146, 230
- Forward All Calls 230
- Forward Busy 144
- Forward Emails
 - External Systems 259
- Forward Hunt Group 145, 156, 307
- Forward Hunt Group Calls Off 156
- Forward Hunt Group Calls On 156
- Forward Message 259
- Forward No Answer 144, 154
- Forward Number 156, 307
- Forward on Busy 139, 144, 145, 156, 230, 307
- Forward On Busy Number 156, 307
- Forward On Busy Off 156
- Forward On Busy On 156
- Forward on No Answer 131, 144, 156, 230, 307
- Forward On No Answer Off 156
- Forward On No Answer On 156
- Forward Unconditional 144, 145, 156, 307
- Forward Unconditional Off 156
- Forward Unconditional On 156
- Forward voicemails 185
- Forwarding 145, 220
 - Email 259
 - Multiple 259
 - Multiple Mailboxes 259
 - voicemail 234, 240
- Forwarding except 145
- FRAD 181
- frame instructs 170
- Frame Relay 167, 192, 193, 195, 234, 314
 - Encapsulation 170
 - framed 181
- Frame Relay Assembler Disassembler
 - IP Office employs 181
- Frame Relay Encapsulation 314
- Frame Relay's PVCs 181
- framed 167, 170, 192, 193, 195, 234, 314
 - Frame Relay 181
- Front Door 120
- FSK 313
- FTP 197
- G -
- G.711 77, 80, 82, 85, 86, 87, 168, 170
 - including 161
- G.711 A-law/U-law 170
- G.711A 185
- G.711MU 185
- G.723 97
- G.723.1 168, 170
- G.723.1 MP-MLQ 170
- G.723.1. 161
- G.723.1-6K3 185
- G.726 16kbps ADPCM 256
- G.729 97, 170
- G.729 Annex 170
- G.729a 103, 161, 168, 185
- G.729a/b 77, 80, 82, 85, 86, 87
- G711
 - encoding 101, 103
- Gatekeepers 158, 161
 - requests 160
- Gateway 14, 99, 114, 158, 160, 161, 167, 181, 192, 193
- Greetings 233, 234, 251, 259
- Greetings & Mailbox Navigation 233
- greetings provide 251
- Ground Start 14, 54, 174, 298, 313, 343, 348
- Ground-Start 174
- GROUP 291
- Group Listen 156
- Group Listen Off 156
- Group Listen On 156
- Group working 97
- H -
- Handover 97
- Hands Free Pouch 99
- Handset 20, 45, 85, 86, 87, 97, 99, 110, 111, 112, 116, 126, 130, 135, 150, 152, 181, 195, 228, 229, 234, 253
- Handset Liquid Crystal Display 112
- handset offers
 - high-resolution 99
- Handset Volume Control 112, 116
- Hands-free/ Speakerphone 111
- Hardware 44, 97, 226, 263, 332
- Hardware provides 44
- Head Office 17
- Header Compression 169, 170, 314
- Header Message 259
- Headset 77, 80, 82, 85, 86, 87, 99, 110, 111, 112, 117, 123, 155, 156
- Headset Socket 77, 80, 82, 85, 86, 87
- Headset Toggle 156
- headset/microphone 158
- Heat Dissipation 310
- Held Calls Panel 220
- Held Panel 220
- Help Desks/Support Desks 248
- HH 291
- High Voltage 117, 346

- Hold 7, 77, 80, 82, 112, 116, 127, 128, 129, 133, 134, 146, 156, 192, 194, 220, 251, 259, 306
- Hold Call 128, 156, 220
- Hold Call Waiting 128
- Hold CW 156
- Hold Music 127, 128, 156
- Hong Kong 300
- Hook 150, 155
- Hook Dialing 150
- Hot Desk 134, 183
- Hot Desking 134
- Hours greeting 153
- HP's Network Node Manager 295
- HTTP 197
- Hunt Group Broadcast Messages 252
- hunt group call handling 145
- Hunt Group call ringing 135
- Hunt Group Calls 135, 136, 145, 152, 153
- Hunt Group Disable 156
- Hunt Group Enable 156
- Hunt Group Enable/Disable 132
- Hunt Group exceed 154
- HUNT GROUP EXTENSION 291
- HUNT GROUP NAME 291
- Hunt Group Recording 255
- HuntGroup.csv 291
- Hybrid™ PBX 158
- Hz 165
- I -
- I55 185
- Iceland 300
- ICLID 174
- Illuminated 3-line 110
- Illuminated 5-line 111
- IM 217
- Immediate Reboot 291
- IMS 263
- IMS Pro Connection 263
- IMSAdmin 263
- Inbound Call Handling 151
- Incoming Call 132, 151, 174, 196, 217, 220, 232, 234, 255
- Incoming Call Routes 132, 151, 232, 234, 255
- incoming call scripting 217
- India 300
- indicating
Talk 112
- industry-standard 185
- Information Bulletin Boards 248
- Information Protocol
Routing 198, 314
- Information within Call Flows 248
- Inhibits
COLP 174
- Inline Power 10/100 BaseT Switching Module 165
- input rating
power 310
- In-Queue Announcements 259
- Insert 127, 248, 256
- Installation Guide 112
- INT 298
- Integral 10/100 Mbit Layer 194
- Integral Static 15
- Integral T3 58
- Integral T3 IP 58
- Integrated H.323 Gatekeeper 14
- Integrated Management Suite 295
- Integrated Messaging 16, 259
- Integrated Messaging Pro 16, 18, 263
- Intelligent 7, 151
- Interaction 7, 248, 254
Voicemail 240
- Interactive Voice Response 7, 16, 44, 248
building 234
- Interchange 185
- Internal Call 129, 136, 308
- Internal Daughter Cards 349
- Internal Directory 183
- Internal Modem 17, 332, 349
- Internal Modem Card 17, 349
- Internal Twinning 136
- Internal/External 251
- Internal/External greeting 251
- Internet Access 15, 167, 192, 195, 332
- Internet browsing 197
- Internet Explorer 256
- Internet IP Security Domain
Interpolation 314
- Internet Key Exchange 314
- Internet Protocol 158
Security Architecture 314
- Internet Protocol Control Protocol 314
- Internet Protocol refers
type 158
- Internet Security Association 314
- Internet Service Provider 197
- Internet Standards/Specification 170
- Internet Telephony 7, 14, 178
- Internet Telephony Service Providers 178
SIP trunking 14
- internets 314
- Internetworking 185
- interoperability 182, 230
messaging 185
- Interoperable 185
- interoperate 198
networking 14
- interoperation 198
- Interpolation
Internet IP Security Domain 314

- Interquartz 117, 120, 124
- Interquartz Doorphone 120
- Interquartz Gemini 117, 124
- Interquartz Gemini 9281-AV 124
- Interquartz Gemini Phones 117
- Introduction 58, 290
 - IP Telephony 158
- Intrude 133, 134, 154, 229, 234, 307
- INTUITY 185, 217, 234, 243, 244, 245, 251, 252, 253, 258, 259
- Intuity Audix 185, 259
- Intuity Audix 4.4 185
- Intuity Audix Emulation Features 259
- Intuity AUDIX™ 185
- Intuity Emulation 232
- Intuity Feature 259
- INTUITY Mode 243, 244, 245, 253
- Intuity TUI 259
- Invited 220
- IP Address Assignment 77, 80, 82, 85, 86, 87
- IP application
 - LAN 167
- IP Authentication Header 314
- IP DECT 3700 226
- IP DECT Capacities 97
- IP DECT IPO STARTER KIT 97
- IP DECT System 97
- IP DECT Telephone 97, 110, 111
- IP DECT Wireless Handset 124
- IP Encapsulation Security Payload 314
- IP extension calling 301
- IP Extensions 17, 161, 301
- IP Hard Phone 158
- IP Office Management Utilities 290
- IP Office Manager 17, 45, 129, 133, 139, 146, 174, 197, 244, 251, 252, 255, 263, 277, 291, 296
- IP Office Phone Manager application maintains 147
- IP Office Phone Manager Lite 277
- IP Office Phone Modules 346
- IP Office Professional Edition 45, 234, 259, 276, 298
- IP Office Professional Edition Upgrade 45
- IP Office Small Community Networking 128, 129, 131, 133, 135, 146, 182
- IP Office Standard Edition 45, 276, 301
- IP Office stores
 - list 141
- IP Office Support Fax 169
- IP Office Supports 169, 198
- IP Office Time Profiles 255
- IP Office Voicemail Pro CD 263
- IP Office Voicemail Pro Intuity Audix Emulation Features 259
- IP Office VoIP 169
- IP Office's 178
- IP Office's Directory 127
- IP Office's list 141
- IP Offices Transit Network Selection 174
- IP Office's WAN 181
- IP Packet 170, 181
- IP Packet Flow Control 170
- IP PBX 158
- IP Phone Adapter 165
- IP Phone Power Adapter 165
- IP Phones 44, 45, 77, 80, 82, 147, 154, 160, 165
- IP Power 165
- IP Security Document Roadmap 314
- IP Service 192
- IP Telephone Power Consumption 165
- IP400 3rd PRTY IVR RFA 248
- IP400 Access Point RFA 298
- IP400 Analog 16 17
- IP400 Analog Trunk 16 17, 54, 301, 348
- IP400 Analog Trunk 16 Module 54, 348
- IP400 BRI Card 343
- IP400 BRI-8 298
- IP400 Digital Station 55, 347
- IP400 Digital Station V2 Module 55, 347
- IP400 Dual E1R2 343
- IP400 Dual PRI E1 298, 343
- IP400 Dual PRI T1 298, 343
- IP400 E1R2 343
- IP400 Internal Modem Card 349
- IP400 Modem 12 298
- IP400 Modems 298
- IP400 Phone 129, 301, 346
- IP400 Phone Manager PC SoftPhone RFA 10 301
- IP412 15, 17, 44, 45, 54, 88, 155, 161, 169, 192, 194, 232, 259, 276, 298, 310, 313, 332, 343, 349
- IP412 Control Units 298, 310, 332
- IP412 Maximum Heat Dissipation 310
- IP412 Office A-Law Base Unit 298
- IP412 Office Mu-Law Base Unit 298
- IP412 providing 298
- IP412 Supports Two 64-party Conference Banks 276
- IP500 15, 16, 17, 18, 44, 47, 54, 55, 88, 155, 161, 169, 174, 183, 192, 194, 232, 234, 259, 276, 298, 301, 310, 313, 343, 345, 349
 - default 45
 - existing 52
 - voicemail 233
- IP500 Analog Phone 52
- IP500 Analog Trunk 16 54
- IP500 Analog Trunk 16 Expansion Module 54
- IP500 Analog Trunk 16 Module 54
- IP500 Analog Trunk Card 52
- IP500 BRI 52, 54, 174, 345
- IP500 BRI So8 54, 345
- IP500 BRI So8 Expansion Module 54, 345
- IP500 BRI So8 Module 345

- IP500 BRI Trunk Card 52
- IP500 Cards 47
- IP500 Compact Flash voicemail 16
- IP500 Control Unit 45, 47, 298, 301
- IP500 Digital Station 52, 54, 55, 301
- IP500 Digital Station Expansion Module 54
- IP500 Digital Station Module 55
- IP500 Expansion Modules 45
- IP500 Feature Key 301
- IP500 Feature Key A-Law 301
- IP500 Legacy Card Carriers 47, 52, 298, 301, 343, 349
- IP500 Media Card Voice Compression Module 32 298
- IP500 Media Card Voice Compression Module 64 298
- IP500 Phone 54
- IP500 Phone Expansion Module 54
- IP500 PRI 52
- IP-based WiFi 90
- IPCP 314
- IP-DECT 97
- IPSec 15, 181, 199, 314
- IPSec Tunneling 199
- IPSec VPN 181
- IP-telephony 165
- Ireland 300
- ISAKMP 314
- ISBN
- asked 249
 - enters 249
- ISDN 14, 52, 151, 167, 170, 173, 192, 193, 194, 217, 298, 313, 343, 345
- BRI S-interfaces 54
 - following 174
 - incoming 174
 - outgoing 174
- ISDN Basic 174
- ISDN Basic Rate 174
- ISDN BRI S-interface 298
- ISDN DSS1 174
- ISDN MSN 151
- ISDN Ports 313
- ISDN Primary 174, 298
- ISDN Primary Rate 174, 298
- ISDN T-Bus Basic Rate Interface 298
- ISDN/PRI 151
- ITAddress 306
- ITU-T Recommendation E.164 314
- IVR 7, 16, 234, 248, 259
- providing 250
- J -
- Japanese 234, 249
- Juniper 114
- K -
- Kbps 183
- LAN 169
 - Point 169
- Kentrox 114
- Key Management Protocol 314
- Key System 158
- Keyboard Actions 225
- Keyboard Mapping 225
- Kit List 301
- L -
- L2TP
- Securing 314
- Lamp Operation 138
- Language 110, 111, 131, 147, 230, 232, 233, 234, 244, 246, 249, 291
- language depending 232
- Lanyard 99, 103
- Last Number Redial 117, 156
- Latin 234, 249
- Latin American 234
- Latvia 300
- launch 296
- Layer Two 314
- Layer Two Tunneling Protocol 314
- LCD 112, 117, 130
- LCP 196, 314
- LCR 188
- Existing 142
- LCS 217
- LDAP 15, 198
- leading
- email 243
- Leased Line 15, 173, 192, 194, 195
- types 194
- Leased Line Support 194
- Least Cost 141, 142, 153, 172
- Existing 188
- Least Cost Routes 141, 153
- Least Cost Routing 142
- Existing 188
- LED 85, 86, 87, 117, 165
- Legacy Card Carrier 45, 52
- License Key 18, 199, 229, 233, 244, 248, 301
- License.csv 291
- LIFO/FIFO 259
- Link Control Protocol 196, 314
- Linked Numbering 189
- Linked Numbering Scheme 189
- Lite 16
- Lithium Ion Battery 103
- Lithuania 300
- LLB 52, 174, 343
- Local Area Network 158, 161, 192, 194, 198, 230
- Local End Echo Cancellation 25ms 170

- Local Phone Directory 217
- Local Telcos 174
- Locating
 - SIP Servers 314
- Longest Waiting 152, 225
- Loop Disconnect 346
- Loop Greeting 259
- Loop Start 14, 54, 174, 298, 343, 348
- Loop start/Ground 313
- Loop-Start 52, 174
- Lord Of The Rings 249
- Lotus Notes 240, 243
- Low-Speed Serial Links 314
- LS 343
- Luxembourg 300
- M -
- Mail Box
 - Remote Access 259
- Maintainers Network Manager 295
- make/receive
 - headset/microphone 158
- Malicious Call Identification 174
- Manage voicemail 258
- Managed Frame Relay Network 181
- Managed IP VPN 167, 181
- Management Tools 17
- Manager 5.1 291
- Manager application 134
- Manager provides 291
- manager/secretary 139
- Managment Information 314
- Many Avaya 129, 138, 146
- Many Simultaneous Calls Can 168
- MAPI 16, 240, 263
- Mbps 170, 181
- Mbps LAN 181
- MCID 156, 174
- MCID Activate 156
- MCU 160
- MDAC 248
- Media 17, 160, 167, 170, 225, 229, 244, 295
- Media Service Provider 229
- Medical 7
- medical issues 7
- Medium-Size Companies 7
- Meet Me conferencing 274
- Meeting 131
- Meet-Me 45, 275, 276
- Meet-Me conferencing 45
- Meet-Me Conferencing on IP500 276
- Meet-Me Conferencing Solution 275
- Memory 112, 117, 128, 167, 298, 313
- Menu Bar 220
- MERLIN MAGIX 58
- Message Announcements 259
- message archiving 263
- message handling
 - individuals 234
- Message light 116
- message recording 263
- Message Storage Capacity 232
- Message Waiting 18, 85, 86, 87, 112, 117, 129, 173, 252, 258
- Message Waiting Indication 117, 129, 185, 259, 346
- Message Waiting Indicator 77, 80, 82
- message waiting lamps 129
- Message Waiting Light 116, 185
- Messages Button 80, 82
- messages consume 263
- Messaging Card 17, 295
- Microsoft application 196
- Microsoft Live 217
- Mid Span Power 165
- Middle East 300
- Mid-Span 165
- Mid-Span Power Distribution Units 165
- Miercom 7
- milli-seconds 168
- ML-PPP 195, 314
- MM 291
- mm/inches 310
- Mobile Twinned Call Pickup 156
- Mobile Twinning 18, 45, 156, 247
- mobile/cell 136, 144, 145, 234, 240, 253
- Mobile/Cell Phone 136, 144, 145, 234, 240
- Mobility 20, 90, 97, 99, 112, 126, 134
- Mobility Solutions 90
- Modify' 252
- Modify' existing lists 252
- Modular 17, 44, 232, 258
- Modular Messaging 258
- Modular Messaging Voicemail 232
- Monitor 52, 134, 150, 154, 174, 217, 225, 229, 230, 255, 256, 276, 290, 294, 295, 296, 343
- Monitor Calls 154
- Most Avaya 147
- MP 314
- MPPC 314
- MSDE 256
- MSP 229
- Mu-law 298
- Multiclass 170
- Multi-Class Extension
 - Multi-Link PPP 314
- Multiclass Extensions
 - Multilink PPP 170
- Multi-Level Tree Structure 259
- Multi-Link 167, 195, 314
- Multilink PPP

- Multilink PPP
 - Multiclass Extensions 170
- multiple incoming 138
- Multiple Mailboxes
 - Forward 259
- Multiple Subscriber Number 174
- Multiple Time Entries 153
- multipoint 160
 - point 174
- Multipoint Connection Units 160
- MultiVantage 185
- Music-on-Hold 298
- Mute 77, 80, 82, 110, 111, 116, 117, 146
- MWI 129, 346
- N -
- NA 90, 347
- NAME 291
 - Calling 220
- NAT 15, 181, 197, 314
 - discover 178
- Netgear 114
- Netherlands 300
- Network Address Translation 15, 181, 197, 314
- Network Address Translators 314
- network addresses 15, 181, 197, 314
- Network Alchemy 45
- Network Assessment 169
- network called
 - Public Switched 158
- network comprising 198
- Network Manager 295
- Network Manager application 295
- network numbering 189, 197
- Network Numbering Schemes 189
- network ready 7
- Network Requirements 167
- Network Time Protocol 314
- Networked Messaging 234, 245
- Networked Messaging Solution 245
- Networking Features 183
- Networking maximizes 172
- networks converging voice 99
- networks including private 158
- New message 129, 193, 244
- new/old/saved 130
- new/repeat/answered/unanswered 117
- NI2 174
- Night Service 151, 152, 153, 307
- Night Service Fallback 152
 - Pass 153
- Night Service Group 152
- No Answer 136, 144, 145, 156, 220, 307
- No Answer Interval 144
- No Answer Time 136
- Node Numbering 189
- Node Numbering Scheme 189
- North American Primary Rate Interface 174
- North American T1 174
- Norway 300
- Norwegian 110, 234, 249
- Not Disturb 133, 144, 146
- Not Disturb Exception Add 156
- Not Disturb Exception Delete 156
- Not Disturb Off 156
- Not Disturb On 156
- Notice 7
- Now there's 7
- NTP 314
- NULL Encryption Algorithm 314
- Number service 174, 247
- number/name 259
- number' 128
- Numeric Keystrokes 225
- Nylon Pouch 99
- O -
- OAI 99
- Octel 185
- Of Hours 251
- Off Hook Current 313
- Off Hook Operation 155
- Off Hook Station 156
- Offer/Answer Model 314
- offering
 - high-resolution 99
 - high-resolution backlight 99
- Off-Hook Station 155
- office heating 234
- Office LAN
 - accessing 332
- Office-quality speakerphone 103
- Oldest 154, 256
- oldest ringing/waiting 154
- oldest ringing/waiting call 154
- On Demand Call Recording 234
- Open Application Interface 99
- Open CTI 16
- OpenView application 295
- Operator SoftConsole 16
- Optional Add-Ons 85, 86, 87
- Other Avaya Products 58, 185
- Other Features 259, 276
- Out Of Hours 251
- Outbound Call Handling Features 141
- outcall 253
- Outcalling 259
- Outlook 16, 217, 243
 - Goldmine 217
- Output Port 120, 313
- Overflow Group 152
- Overhead LAN 168

- Overhead WAN 168
- P -
- PABX's 14, 160
 - provide 17
- Packet Based 181
- Packet Based Voice Networking 181
- packet filtering 197
- packet switching 181
- packetization 170
- packetized VoIP
 - allowing 181
- packetized VoIP calls 181
- packets arrive
 - port 170
- packet-switched 158
- Packet-Switched Telephony 158
- Packet-switched VoIP 158
- Pager 240
- Paging
 - Calls 136
 - receiving 346
- Pakistan 300
- Pan European Connection 313
- PAP 193, 196, 198, 199, 314
- Park 128, 129, 136, 156, 220, 225, 226, 234, 254, 308
- Park Call 156
- Park ID's 220
- Park Return 136
- Park Slot Panel 220, 225, 226
- Park Slots 128, 220, 225, 226, 254, 308
- pass calls 153
- Password 130, 193, 196, 226, 291, 314
- PC application 252
- PC application Phone Manager Pro 252
- PC Based 232
- PC Requirements 263
- PC Softphone 16, 45, 126, 217
- PC Softphones 20
- PCMCIA 298
- PCMCIA Slots 298
- PCMCIA Wireless 298
- Permanent Virtual Circuits 181, 195
- Personal 247
- Personal Distribution Lists 217, 252
- Personal Numbering 234, 247, 259
- Personal Options 259
- Personalized Greeting 259
- Personalized Ring Patterns 77, 80, 82, 85, 86, 87
- Personalized Ringing 116, 129
- Phone 16 298, 310
- Phone 16 Module 298, 310
- Phone 16 Module V2 298
- Phone 30 Module 298, 310
- Phone 30 Module V2 298
- Phone Manager application 132, 133
- Phone Manager Feature Summary 217
- Phone Manager GUI 251
- Phone Manager Lite 16, 45, 147
- Phone Manager Lite/Pro/PC Softphone 45
- Phone Manager PC Softphone 18, 158
- Phone Manager Pro 16, 18, 45, 120, 135, 147, 217, 251, 252, 259, 301
- Phone Manager Pro PC Softphone 45, 301
- Phone V2 346
- physical/logical 169
- Pickup 135
- Pick-Up 131
- PIN 16, 142, 248, 259, 277
 - prompted 232
 - requesting 275
- PIN checking 248
- PIN Code By-Pass 259
- PIN code/menu 277
- PIN Restricted Calling 142
- Plain Old Telephone Services" 158
- Plain Ordinary Telephone 298
- Platform Support 259
- Play Advice
 - switching 255
- played back 251, 259
- PoE 58, 77, 80, 82, 84, 85, 86, 87, 97, 158, 165
- Point Compression
 - Microsoft Point 196, 314
- Point Protocol
 - Point 314
- Point WAN 169
- point-to-multipoint 345
- Point-to-Point 174, 181, 192, 193, 195, 345
- Point-to-Point Protocol 192, 195
- Power Distribution Units 165
- Power Fail Ports 313
- Power Options
 - IP Telephones 165
- Power Supply 77, 80, 82, 84, 85, 86, 87, 165, 298, 310
- Power Supply Units 310
- Powered Data Unit 165
- Powered LAN 58
- PPP 170, 192, 195, 199, 314
- PPP Fragmentation 170
- PPP MP 314
- PPP Multilink Protocol 314
- PR 174
- PRI 14, 15, 45, 47, 52, 172, 174, 301, 313, 332, 343
- PRI 30 E1 47
- PRI 30 E1R2 RJ45 47
- PRI 48 T1 301
- PRI 60 E1 301

- PRI E1 313
- PRI ISDN Services 313
- PRI ISDN Switch 313
- PRI T1 15, 47, 313
- PRI T1 Service 313
- PRI T1/J1 313
- prices—Avaya 7
- Primary Rate ISDN 174
- Primary Rate Trunks 52, 174, 343
- prioritization 99
- Priority 7, 77, 80, 82, 99, 151, 156, 158, 253, 307
- Priority Call 151, 156
- Priority Processors 99
- Privacy Mechanism
 - Session Initiation Protocol 314
- Private 7, 52, 134, 141, 156, 158, 172, 173, 181, 185, 192, 197, 252, 253, 298, 343
- Private Call 134, 156
- Private Call Off 156
- Private Call On 156
- Private Circuit Switched 173
- Private Circuit Switched Voice Networking 173
- Private Networking 185
- Private Voice Networks 52, 172, 343
- Pro 16, 120, 240, 263, 277
 - upgrades 18
- Pro provides 16
- Product 7, 114, 117, 154, 156, 185, 226, 228, 229, 230, 243, 263, 298, 343
 - receiving 7
 - time during 18
- product configuration documents 156
- Product Configurations 156, 298
- Product Description 154, 343
 - Operating System 226, 263
- Professional Edition 18, 276, 301
 - Standard Edition 45
 - upgrade 45
- prompting
 - PIN 232
 - Voicemail Pro 246
- Protocol Applicability Statement 314
- protocol passing 197
- Protocols 52, 97, 99, 158, 160, 161, 167, 170, 181, 185, 195, 197, 198, 243, 294, 314, 343
- protocols including 197
- Proxy Address Resolution Protocol 197
- PSK 103
- PSTN 138, 167, 169
 - IP Office connects 158
 - SCN 142, 188
- PSU 310
- PTT 104
- Public 7, 15, 52, 114, 129, 141, 142, 153, 158, 160, 169, 172, 174, 181, 194, 197, 199, 234, 252, 314, 343
- Public Network 141, 142, 160, 181
- Public Switched 169
 - network called 158
- Public Switched Telephone Network 169
 - called 158
- Public Voice Networking 174
- Pulse 135, 155, 174, 346
- Pulsed High Voltage 346
- Push 120
- push-to-talk” 99
- Put_EventFilter 306
- PVCs 181, 195
- Q -
- Q.931 170, 174, 181, 182
- Q.931 signaling 174
- QoS 14, 77, 80, 82, 85, 86, 87, 99, 167, 169, 181, 296
- QoS Options 77, 80, 82, 85, 86, 87
- QoS/Class
 - Service 169
- QSIG 14, 138, 174, 183, 185
 - following 173
 - limit 45
 - running 258
 - terminates 173
- QSIG Networking 14
- QSIG provides
 - level 173
- QSIG signaling 173
- Quad Chargers
 - 3641 99
- Quality Assurance 135
- Queue Announcements 232, 234, 259
- Queue Entry Announcement 259
- Queue Manager 16
- Queue Mode 225
- Queue Panel 220
- queue panel displays
 - bar 220
- queue position 259
- Queue Position Announcement 259
- Queue Threshold Alert 154
- Queue Update Announcement 259
- QUEUING 291
- Quick Charger 99
- Quotas 192, 193, 195, 308
- Quotas place 192
- R -
- Radio Frequency 2.4000 101, 103
- Radio Frequency 2.4000 GHz 103
- RAID 263
- RAS 167, 198, 332
- Rate Adaptation 314
- Rating
 - 24V DC 310

- reachability 7
- reading
 - email 16
- Real Time 16, 170, 234, 314
- Real Time Control Protocol 170, 314
- real time tracking 16
- Reattempt 220
- Reboot When Free 291
- Rec 314
- Recall button 116, 117
- receiver's 158
- Receiving Door 120
- Reception 129, 155
 - Breakout 259
- Rechargeable Battery 112
- Reclaim Call 132
- Record Message 156, 254
- Record/Send 259
- recorded message stating 254
- Recording 255
 - Time 259
- Recordings 254, 255, 256, 263
- Redial Button 112, 116
- Region 90, 97, 115, 124, 301
- RegisterCallNotifications 306
- relating
 - conferencing 277
- Relay Off 156
- Relay On 156, 234
- Relay On/Off/Pulse 135
- Relay Pulse 156
- Release 4.0 296
- Release 4.0.7. 97
- Release 4.1 153, 194
- Remote Access 15, 17, 20, 126, 167, 192, 193, 198, 234, 298, 332, 349
 - Mail Box 259
- Remote Access Features 193
- Remote Access Server 15, 17, 198
- Remote Access Services 20, 126, 192, 193, 332
- Remote Hot Desking 134, 183
- Remote Management 277
- REN 313, 346
- Repeat Message 259
- Replay 234, 256
- replay rights 256
- Reply 233, 244, 251, 259
- requesting
 - Gatekeeper 160
 - PIN 275
- Rest 192
 - World 276
- restricted/allowed 197
- Resume Call 156
- Retrieve Call 156
- Return On Investment 274
- Rewind Message 259
- RFA 185
- RFC 170, 314
- Ringer 85, 86, 87, 112, 116, 117, 129, 154
- Ringer Equivalency 116
- Ringer On/Off 112
- Ringing
 - Patterns 116
 - Volume Control 116
- RIP 15, 198, 314
- RJ45 Ethernet 313
- RMS 313
- ROI 274
- ROTARY 291
- router alleviates 192
- router/firewall/DHCP 17
- Routing Information Protocol 198, 314
- RTP 168, 178, 314
- RTP Payload
 - DTMF Digits 314
- RTP Relay 178
- RTP Voice Data Payload 168
- RTP/RTCP 170, 314
- Ruggedized 102, 103, 104, 124
- Russia 300
- Russian 234, 249
- RW 256
- S -
- S Message 308
- S0 174
- S0 Endpoint
 - Call 174
- S3210 185
- Save Message 259
- Save Profile 220
- SBC 178
- S-Bus 345
- scalable 17, 172, 243
- Scalable Platform 17
- Scan' 252
- SCN 45, 134, 152, 183
 - PSTN 142, 188
- Screen Pop 217, 229
- Screen-Popping 127
- SDP 314
- Search 225, 256
- Secondary Dial Tone 133, 156
- secretary's 133
- Securing
 - L2TP 314
- Security Architecture
 - Internet Protocol 314
- Self-Administration 150
- Send Email 259, 295

- Send Instant Messages 217
- Separated incoming/outgoing 217
- Series 18, 47, 54, 55, 58, 77, 80, 82, 84, 116, 124, 226, 230, 234, 310, 347
- Server PC 263
- server PC's 310
- servers provide 196
- Service Packs 226, 263
- Service Provider conferencing
 - compared 274
- Service Provider conferencing services 274
- service provider supporting 127
- Service Providers 14, 44, 127, 174, 178, 181, 199, 217, 274
- service-by-service 195
- Session Border Controller 178
- Session Description Protocol 314
- Session Initiation Protocol 158, 170, 178
 - Privacy Mechanism 314
- Set Absent Text 156
- Set Account Code 156
- Set Authorization Code 156
- Set Hunt Group Night Service 156
- Set Hunt Group Out
 - Service 156
- Set Hunt Group Out Of Service 156
- Set Inside Call Seq 156
- Set Message Priority 259
- Set Mobile Twinning Number 156
- Set Mobile Twinning Off 156
- Set Mobile Twinning On 156
- Set No Answer Time 156
- Set Outside Call Seq 156
- Set Ringback Seq 156
- Set Wrap Up Time 156
- SetCallInfoBuffer 306
- short code representing 254
- Short Codes 128, 153, 154, 155, 156, 183, 195, 233, 254, 277
- Short Message System 240
- shortcode 346
- ShortCode.csv 291
- Shut Down Embedded Voicemail 156
- Signaling
 - Conforms 174
- Signaling Channels 97, 174
- Silence Suppression 161, 170
- Simple Network Management Protocol 295, 314
- Simple Outlook 217
- Simple Telephony Call/Basic 173, 185
- Simple Telephony Call/Basic Call 173, 185
- Simple Traversal
 - UDP 178
 - User Datagram Protocol 314
- Simultaneous 169
- Simultaneous VoIP Calls
 - Maximum Number 169
- Small Community Network 128, 129, 131, 133, 134, 135, 146, 152, 182, 183, 185, 234
- SMDR 45, 141, 229
- SMI 101
- SMS 240
- SMS/text 243
- SMTP 16, 234, 240, 263, 290
- SMTP email 290
- SMTP/POP3 243
- SNMP 77, 80, 82, 85, 86, 87, 165, 181, 290, 295, 314
- SNMPv1 314
- So8 298, 310, 332
- So8 Module 298, 310, 332
- Soft 14, 103, 132, 332
- SoftConsole 18, 45, 128, 131, 135, 146, 155, 220, 225, 226
- SoftConsole Administration 226
- SoftConsole gives
 - operator 220
- SoftConsole Options 225
- SoftConsole PC Requirements 226
- SoftConsole Telephone Requirements 226
- Software Developers Kit 228
- Software Development Kit 16, 229
- Software License Feature Key A-Law 298
- Software License Feature Key Mu-Law 298
- software/documentation CD 298
- SOHO 133
- Sophisticated Queue Announcement 234
- SOS Emergency key 110
- Speaker button 150
- Speaking Clock 234, 259
- Special Features
 - 4625 SW 82
 - 5410 80
 - 5420 82
 - 5621 SW 82
- Special Services 174
- Specialty Handset Support 116
- Speed Dial 80, 82, 88, 146, 217
- Speed Dial List 80, 82
- Sprint 174
- SQL 248
- SQL Query Builder Wizard 248
- SSA 296
- SSA connects 296
- SS-CNIP 173
- SS-CNIR 173
- SS-CONP 173
- SS-CT 173
- SS-MWI 173
- SSS 174

- STAC 314
- Stac Lemple Ziv 196
- STAC LZS Compression Protocol 314
- stackable 45, 332
- Stand
 - Charging 112
- Stand Power Supply Adapter
 - Charging 112
- Standard 40W Power Supply Unit 310
- Standard Edition 18
 - Professional Edition 45
- standards-based 14, 15, 151
- standards-based TAPI 151
- Starter Kits” 97
- starting
 - Day One 7
- station/access 58
- Status 17, 45, 84, 101, 131, 134, 139, 146, 152, 220, 225, 230, 234, 256, 290, 296
- Status Application 17, 45, 296
- Status Bar 220
- STD15 314
- STD16 314
- STD17 314
- STD56 314
- STD57 314
- Still Queued 234
- strings 174
 - Absence Text 131
- Structured Query Language 248
- STUN 178, 314
- Sub-addressing
 - Allows 174
- subject 7, 127, 154, 255
 - email 240
- Summary 52, 124, 169
 - Positioning 232
- Supervised Transfer
 - called 129
- supervisor's Coverage Timer 136
- Supervisors 132, 136, 252
- Supplementary Service 181, 182
- Supplementary Services within 182
- Supplementary Services within IP Networks 182
- surfing
 - Internet 332
- Suspend Call 156
- Suspend CW 156
- Sv 308
- SW 77, 80, 82
- SwapHold 306
- Sweden 300
- Swedish 110, 111, 234
- switchable 80, 82, 117
- Switchable Time Break Recall 100 117
- Switched Ethernet 15, 45, 332
- Switched LAN 17
- switching
 - Capacity 313
 - Play Advice 255
 - WAN 181
- synchronization 198, 259
 - Phone Manager 15
- System Administration 256
- System Administrator 127, 129, 132, 156, 255, 256
- System Announcement 259
- systems supporting 245
- T -
- T.38 161, 169
- T.38 Fax 169
- T1 14, 15, 17, 52, 129, 138, 142, 172, 173, 174, 185, 188, 194, 258, 276, 298, 301, 332, 343
- T3 55, 58, 85, 86, 87, 88, 124, 130, 174, 310, 347
- Tabs 217, 220, 225, 277
- TAPI 16, 45, 127, 229, 230, 306, 307
- TAPILink Lite 229, 230, 306
- TAPILink Pro 229, 230
- TAPI-WAV 229, 230
- Target RAS 308
- TCP 314
- TCP/IP 17, 263, 314
- TCP/UDP/IP 170
- Technical Bulletin 178, 226, 263
- Technical Specifications 226, 263
- Technology Overview 160
- TEIs 345
- telecommunication 314
- telecommunication numbering 314
- Telecommuter 135, 217
- Telecommuter Mode 135, 217
- teleconferences 7
- Telephone Adaptors 17, 193
- Telephone Cord 112
- Telephone Devices 230
- telephone establish 160
- Telephone Extension Cable Lengths 310
- Telephone Options 18
- Telephone User Interface 234, 251, 252, 253
- telephone wishing 160
- telephones including 14
- telephones operating 170
- Telephones Section 55, 347
- telephones utilizing Power 165
- Telephony Functions 20, 126
- Telephony Signals 314
- Telephony Tones 314
- telesales 234
- Test Conditions 259
- Text To Speech 16, 18, 234, 244, 249, 259, 263

- Text" 246
Text-to-Speech 234
TFTP 99, 101, 103, 169, 314
that's 7
that's right 7
There's 7
Third Party Database Access 259
Third Party Fax 243
Third Party Text
 Speech 18
Third Party Text To Speech 18
Through Network Address Translators 314
TIA/EIA-646-B
 conform 174
til 131
Time Division Multiplexing 44
time during
 product 18
Time Entries 153
time linking
 office 192
Time Profile 134, 152, 153, 195, 253, 255, 307
timebands 193
Timed Break Recall 346
Time-Division Multiplexed Telephony 158
timeframe 259
timeout 127, 128, 253, 307
TNS 174
To Email 234, 240, 259
Toggle Calls 127, 156
toolkit 229
toolset 16
toolset including 16
Total base-stations/repeaters 97
Transfer call 220
 operator 259
Transmission Control Protocol 314
transmission/reception 174
Transmit Power 100mw 101
TransTalk 9040 58
Tray 220, 226
Tray working 226
trigger/control 155
Trivial File Transfer Protocol 314
Trunk Cards 47, 52, 301, 343
Trunk Interface Cards 298, 332, 343
Trunk Interfaces 14, 17, 298, 332, 343
trunk lines 138, 301
trunk providing 52
trunk/extension 52
trunk/VoIP 276
trunkinterfacecards.htm 343
Trunks back 17
trunks/VoIP 277
TTS 244
 adds 249
TTS Licensing 249
TTY 234
TTY hearing 234
TUI 234, 251, 252, 253
Tunneling Protocol 199, 314
two-base-station 97
- U -
UK 234, 249
UK20 313
unencrypted 196
Uni 47, 298
United Kingdom 300
Universal PRI 52
Unlike circuit-switched 158
unmaps 197
Unpark 156, 306
Unpark Call 156
Unread 'User 220
unsecured' 194
Unshielded Twisted-Pair 310
Unstructured Private Circuit 181
Upgrade License 45, 276
upgradeable 77, 80, 82, 85, 86, 87, 99
Upgradeable Firmware 77, 80, 82, 85, 86, 87
Upgrade-Kit" 97
upgrade-license 97
Upn 85, 124, 310
UPS 165, 310
US T1 PRI 298
USA 300, 313
USA Interfaces 313
use depending 52
Use mailing 259
user according
 type 226
user acquiring
 call 154
User CD-Rom 229
user collecting 193
User Datagram Protocol
 Simple Traversal 314
user determines 139
user ensuring 124
user executing 154
User Interface 16, 103, 158, 234
user interface offering 158
user making 145
user name 220, 308
User Recording 255
user restricting 198
USER RIGHT 291
User Rights 142, 291
Using Text To Speech 16, 249
UTP 310

- V -

- V.24 194, 298, 313
- V.24 Interface
 - 19.2Kbps 313
- V.24/V.28 313
- V.24/V.35/X.21 298
- V.32 52, 193
- V.35 181, 192, 194, 298, 313
- V.90 17, 193, 298, 332, 349
- V.90 56Kbps 193
- V110 314
- V120 314
- V24 194
- V24/V35/X21 298
- V35 194
- V5.0 256
- V90 15
- VAC 165
- VB 18, 234, 250
- VB Scripts 18, 234, 250
- VC 298
- VCM 14, 45, 47, 85, 97, 135, 167, 169, 178, 181, 183, 259, 295, 296, 301, 332, 349
- Virtual 114, 158, 181, 195, 274
 - Voicemail 259
- Virtual Office 114
- Visual Basic 234, 250, 259, 306
- Visual Basic Scripts 259
- Visual Message Waiting Indication 117
- Visual Voice 130, 233, 234, 259
- Visual Voice NOT 130
- VLAN 77, 80, 82, 85, 86, 87
- VM 144
- Voice Call 151, 168, 185
- Voice Communication Solution 14
- Voice Communication Solution Features 14
- Voice Compression 17, 47, 97, 160, 161, 167, 169, 178, 181, 233, 298, 332, 349
- Voice Compression Module 160, 161, 167, 169, 181, 298, 332, 349
- Voice encoding 103, 298
- Voice encoding G711 101
- Voice Forms/Questionnaire Mailboxes 234
- Voice Mail 7, 110, 111, 144, 220, 253
- Voice Messaging 14
- Voice Networking 18, 45
- Voice Priority Processors 99
- voice processing 229
- Voice Recording 135, 234, 255
- Voice Recording Library 263
- Voice Recording Library Management 263
- Voice Recording Library" 256
- voice samples
 - telephone 167
- voice traffic 99, 167, 169, 193
- VoiceDirector 174
- Voicemail 16, 17, 18, 20, 45, 80, 82, 120, 126, 129, 130, 132, 133, 134, 135, 136, 139, 140, 142, 145, 153, 154, 155, 156, 161, 167, 172, 183, 185, 193, 217, 220, 232, 243, 244, 245, 246, 247, 248, 249, 250, 252, 253, 254, 255, 256, 258, 263, 275, 277, 291, 295, 296, 298, 307, 308, 310, 332
 - alter 152
 - control 233, 234
 - distribute 252
 - Email 240
 - Forwarding 234, 240
 - Hunt Groups 259
 - Individual 259
 - Interaction 240
 - IP500 233
 - PC 233
 - routed 251
 - Virtual 259
- Voicemail Box Feature 259
- Voicemail Breakout/Personal Auto-Attendant 233
- Voicemail Collect 156, 233
- Voicemail email 247, 263, 307
- Voicemail Email Connection 263
- Voicemail email forwarding 247
- Voicemail Email Integration 263
- Voicemail Feature Comparison 259
- voicemail greeting 16
- Voicemail Help TUI 259
- Voicemail Node 156
- Voicemail Off 156
- Voicemail On 156, 247, 307
- Voicemail PC 263
- Voicemail Ports 135, 167, 255
- VoiceMail Pro 16, 18, 45, 130, 135, 153, 155, 183, 185, 220, 232, 234, 243, 244, 245, 247, 248, 250, 251, 252, 253, 254, 255, 256, 259, 275, 277, 295
 - 406 332
 - 500MB 263
 - License 263
 - pool 249
 - prompting 246
- VoiceMail Pro application 120
- Voicemail Pro Client 234, 246, 248, 253, 255
- VoiceMail Pro Fax 243
- VoiceMail Pro Manager 246, 259
- VoiceMail Pro Networked Messaging 18, 185, 252
- VoiceMail Pro Networked Messaging RFA 185
- VoiceMail Pro Server 185, 234, 244, 245, 250, 263
- voicemail ringback 129, 156, 259
- Voicemail Ringback Off 156
- Voicemail Ringback On 156
- Voicemail Server 185, 193, 232, 234, 263
- Voicemail System 253, 256
- Voicemails 130, 135, 240, 244, 259

- VoIP 7, 14, 17, 18, 47, 90, 99, 123, 158, 161, 167, 168, 169, 170, 172, 181, 185, 217, 296, 298, 349
- VoIP application 169
- VoIP calls 168, 169
- VoIP provides 158
- VoIP Standards Supported 170
- VoIP Wi-Fi Solution 90
- VoIP-compatible 158
- Voltage 117, 165, 313
- Volts 165
- Volts Alternating Current 165
- Volume 77, 80, 82, 110, 111, 116, 117, 146, 246, 259
- Volume Control
 - Ringling 116
- Volume Down 77, 80, 82
- Volume Up 77, 80, 82
- VPIM 259
- VPN 15, 17, 18, 45, 114, 181, 199
 - following 90
- VPN IPSec/L2TP 18
- VPN Phone Software 114
- VPN Phones 18, 45, 90
 - Licenses 114
- VPN tunneling 17
- VPN-access 114
- VPN-gateways 114
- VRL 263
- W -
- waiting
 - Acquire Call 154
- walkie 99
- walkie-talkie 102
- Wall Plate Adapter 112
- WAN 15, 17, 44, 97, 167, 168, 172, 192, 193, 194, 195, 199, 234, 294, 298, 313
 - switching 181
 - VCM 167
- WAN Expansion Kit 298
- WAN link 192
- WAN multiplexers 193
- WAN3 45, 54, 295, 298, 310
- WAN3 10/100 45, 54, 298
- WAN3 10/100 Module 298
- WAN3 Module 295, 310
- WAP WML 80, 82
- Warm Start 291
- Watts 165, 310
- WAV 128, 217, 225, 240, 244, 256
- wav file 128, 217, 256
- waveform 256
- Web 7, 15, 254, 255, 256, 263
- Web Server 256, 263
- Web Server Operation 263
- Web site 15
- Week Planner 234
- WEP 101, 103
- what's 158
- Whisper Announce 234, 259
- Wide Area 54, 97, 181, 192, 195, 196, 332
- Wide Area Expansion 181
- Wide Area Network 97, 192, 196, 332
- Wide Area Networking Protocol 195
- Width 110, 310
- WiFi 17, 58, 99, 101, 102, 103, 104, 124
- Wink-Start 174
- WINS 194
- Wire 14, 58, 85, 86, 87, 99, 101, 103, 155, 158, 170, 226, 346
 - closet/switch 165
- wire speed 170
- Wired Equivalent Privacy 101, 103
- Wireless 7, 14, 17, 18, 20, 55, 58, 90, 97, 99, 101, 112, 124, 126, 158, 165, 298, 313, 347
- Wireless Access Points 17, 99, 298
- Wireless Module 313
- Wireless Telephones 18, 58, 90, 99, 101, 112, 124
- Wireless VoIP 18
- Within SoftConsole 220
- WLAN 99, 165
- WLAN Compatibility List" 99
- workflow 234
- workforce 243
- workgroup 104
- workgroups 16
- World 115, 158, 192
 - Rest 276
- WorldCom 174
- worlds companies' LANs 158
- Worst Case 165, 310
- Wrap Up 307
- WS-X4148-RJ45V 165
- WS-X6348-RJ45V 165
- X -
- X.21 181, 192, 194, 298, 313
- X.21/V35 WAN 332
- X.25 195
- XM24 55, 124, 347
- XM24 DSS Unit 124
- Y -
- Year 7
- Yes 77, 80, 82, 85, 86, 87, 217, 232, 259
- Z -
- Zetafax
 - Networks 243

Performance figures and data quoted in this document are typical, and must be specifically confirmed in writing by Avaya before they become applicable to any particular order or contract. The company reserves the right to make alterations or amendments to the detailed specifications at its discretion. The publication of information in this document does not imply freedom from patent or other protective rights of Avaya or others.

Intellectual property related to this product (including trademarks) and registered to Lucent Technologies have been transferred or licensed to Avaya.

All trademarks identified by the ® or ™ are registered trademarks or trademarks, respectively, of Avaya Inc. All other trademarks are the property of their respective owners.

This document contains proprietary information of Avaya and is not to be disclosed or used except in accordance with applicable agreements.

Any comments or suggestions regarding this document should be sent to "wgctechpubs@avaya.com".

© 2010 Avaya Inc. All rights reserved.

Avaya
Unit 1, Sterling Court
15 - 21 Mundells
Welwyn Garden City
Hertfordshire
AL7 1LZ
England

Tel: +44 (0) 1707 392200
Fax: +44 (0) 1707 376933

Web: <http://marketingtools.avaya.com/knowledgebase>